

# THE SPIRIT OF ADVENTURE



2018

# CONTENTS

TECHNICAL TENTS	2
ADVENTURE TENTS	37
FAMILY POLED TENTS	57
AIRBEAM® TENTS	82
AWNINGS	115
SLEEPING BAGS	118
ESSENTIALS	145
<b>TREKKING ESSENTIALS</b>	<b>184</b>
TRANGIA	192
WAYFAYRER	199
RUCKSACKS	202
FOOTWEAR	224



## TECHNICAL TENTS

*Our Spirit of Adventure is epitomised in our 2018 collection of Technical tents with a model and design format to suit every need.*

We have upgraded our Trekking range to Trek Pro with a host of elevated specifications to enhance the range and make them lighter and stronger than ever before. New for 2018 is our Experience range of entry level technical tents which are ideal for those exploring the outdoors for the first time.

At the top of the collection, we have included our new “F10 Series”, which brings the superior design specifications that you would expect from Force Ten, into the Vango collection. The pinnacle of technical excellence in trekking and expedition tents, providing a level of design and quality that simply cannot be beaten.

As the number one brand in trekking and expedition tents, we know what it takes to build equipment that performs to provide comfortable and secure shelter in every environment.

### EXPERIENCE

Entry level Technical tents

### TREK PRO

Lightweight backpacking tents for the mountain

### BASECAMP

Trekking tents, with larger living areas

### F10 ALPINE

High performance trekking tents

### F10 ALPINE LT

Ultra light and highly functional shelters

### F10 EXPEDITION

The ultimate kit for extreme expeditions

# TECHNICAL TENT SPECIFICATIONS

	TENT	FLYSHEET	INNER	WINDOWS	POLES	PEGS	GUYLINES	BAG	TBS II	HIGH LEVEL STORAGE	TREK TARP	TREK GEAR STORE	BANSHEE GEAR STORE
EXPERIENCE	Nevis	Protex® 70D 190T 3000mm Polyester	70D 190T Breathable with part mesh door	-----	Vango Powerlite® 7001-T6 Aluminium alloy	7075 Aluminium Alloy	High vizibility	Fastpack bag	-----	-----	✓	-----	✓
	Scafell	Protex® 70D 190T 3000mm Polyester	70D 190T Breathable with part mesh door	-----	Vango Powerlite® 7001-T6 Aluminium alloy	7075 Aluminium Alloy	High vizibility	Fastpack bag	-----	-----	✓	200 & 300 only	-----
	Helvellyn	Protex® 70D 190T 3000mm Polyester	70D 190T Breathable with part mesh door	-----	Vango Powerlite® 7001-T6 Aluminium alloy	7075 Aluminium Alloy	High vizibility	Fastpack bag	-----	-----	✓	✓	-----
BASECAMP	Galaxy	Protex® 70D 190T 5000mm embossed polyester	70D 190T Breathable with zip collapsable part mesh door	Diamond Clear with roll away curtains	Vango Powerlite® 7001-T6 Aluminium alloy	7075 Aluminium Alloy	High vizibility with reflective fleck	Fastpack bag	✓	✓	✓	-----	-----
	Omega	Protex® 70D 190T 5000mm embossed polyester	70D 190T Breathable with zip collapsable part mesh door	Diamond Clear with roll away curtains	Vango Powerlite® 7001-T6 Aluminium alloy	7075 Aluminium Alloy	High vizibility with reflective fleck	Fastpack bag	✓	✓	✓	-----	-----
	Blade Pro	Protex® 68D 5000mm Ripstop	70D 190T Breathable with zip collapsable part mesh door	-----	Yunan Eco Alloy	7075 Aluminium Alloy	High vizibility with reflective fleck	Fastpack bag	-----	✓	✓	-----	-----
TREK	Banshee Pro	Protex® 68D 5000mm Ripstop	70D 190T Breathable with zip collapsable part mesh door	-----	Yunan Eco Alloy	7075 Aluminium Alloy	High vizibility with reflective fleck	Fastpack bag	✓	✓	✓	✓	-----
	Tempest Pro	Protex® 68D 5000mm Ripstop	70D 190T Breathable with zip collapsable part mesh door	-----	Yunan Eco Alloy	7075 Aluminium Alloy	High vizibility with reflective fleck	Fastpack bag	✓	✓	✓	-----	✓
	Mirage Pro	Protex® 68D 5000mm Ripstop	70D 190T Breathable with zip collapsable part mesh door	-----	Yunan Eco Alloy	7075 Aluminium Alloy	High vizibility with reflective fleck	Fastpack bag	-----	✓	✓	-----	✓
	Nemesis Pro	Protex® 68D 5000mm Ripstop	70D 190T Breathable with zip collapsable part mesh door	-----	Yunan Eco Alloy	7075 Aluminium Alloy	High vizibility with reflective fleck	Fastpack bag	-----	✓	✓	-----	✓
	Zenith Pro	Protex® 68D 5000mm Ripstop	70D 190T Breathable with zip collapsable part mesh door	-----	Yunan Eco Alloy	7075 Aluminium Alloy	High vizibility with reflective fleck	Fastpack bag	✓	✓	✓	✓	-----
	Meteor Pro	Protex® 68D 5000mm Ripstop	70D 190T Breathable with zip collapsable part mesh door	-----	Yunan Eco Alloy	7075 Aluminium Alloy	High vizibility with reflective fleck	Fastpack bag	✓	✓	✓	-----	-----
	Pulsar Pro	Protex® 68D 5000mm Ripstop	70D 190T Breathable with zip collapsable part mesh door	-----	Yunan Eco Alloy	7075 Aluminium Alloy	High vizibility with reflective fleck	Fastpack bag	✓	✓	✓	-----	-----
	Halo Pro	Protex® 68D 5000mm Ripstop	70D 190T Breathable with zip collapsable part mesh door	-----	Yunan Eco Alloy	7075 Aluminium Alloy	High vizibility with reflective fleck	Fastpack bag	-----	✓	✓	-----	-----



## TECHNICAL

## EXPERIENCE

Say hello to the all new Experience Technical range. We have created this collection with youth groups, first timers and rookie explorers in mind, using our tried and tested technical knowledge and our long established trekking range as inspiration.

**Experience** focuses on form and function, using a **70D flysheet with 3000mm HH**, a **70D groundsheet with 6000mm HH** and **Vango PowerLite 7001-T6 alloy poles**, these tents are lightweight, highly waterproof and have small pack sizes.



**TECHNICAL**

**EXPERIENCE**



NEVIS 100

NEVIS 200

NEVIS 300

SCAFELL 200

SCAFELL 300

SCAFELL 300+

HELVELLYN 200

HELVELLYN 300

# NEVIS



The Nevis tent balances pack weight, pack size and living space perfectly, to provide a fantastic shelter. Included in the Vango Experience collection, this is an ideal option for those who are looking for a side entry tunnel tent where weight and pack size need to be kept to a minimum. The Nevis features Vango's TBS® II technology increasing performance in adverse conditions, especially in strong and changeable weather. A terrific little tent for those starting to explore the great outdoors.

## SPECIFICATION

- PITCHING** .....All-in-one
- FLYSHEET** ..... Vango Protex® 70 denier polyester flysheet, 3000mm HH
- INNER** .....Breathable polyester inner
- GROUNDSHEET** .....70D, 6000mm lightweight polyester groundsheet
- POLES** ..... Vango PowerLite 7001-T6 alloy poles

## FEATURES

- Tunnel tent - Style provides greatest space to weight ratio
- Patented Vango TBS® II Tension Band System increases tent performs in adverse conditions
- All flysheet and groundsheet seams are factory taped - Provides watertight seal
- O-shaped inner doors - Easy to open with one hand
- Part mesh inner door - Allows ventilation, whilst keeping bugs out
- Internal storage pockets - Provides convenient storage within the inner tent
- Weather tested to the European standard EN5912 by certified test centre
- Fast pack tent bag - Oversized opening and compression straps to control pack size



PAMIR  
200 shown

## 100

TENNEVIS P32077

- TRAIL WEIGHT** ..... 1.49kg
- TOTAL WEIGHT** ..... 1.7kg
- PACKED** ..... 46 x Ø14cm
- PITCHING TIME** ..... 5 mins
- CARTON QTY** ..... 4
- STD ORDER QTY** ..... 4

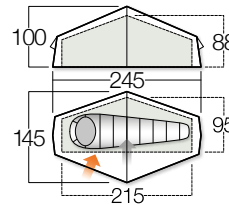

## 200

TENNEVIS P32151



- TRAIL WEIGHT** ..... 1.81kg
- TOTAL WEIGHT** ..... 2.02kg
- PACKED** ..... 46 x Ø15cm
- PITCHING TIME** ..... 5 mins
- CARTON QTY** ..... 4
- STD ORDER QTY** ..... 4

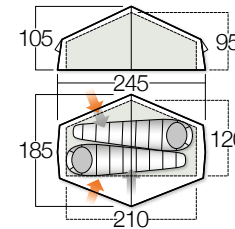

## 300

TENNEVIS P32165

- TRAIL WEIGHT** ..... 2.26kg
- TOTAL WEIGHT** ..... 2.47kg
- PACKED** ..... 46 x Ø17cm
- PITCHING TIME** ..... 5 mins
- CARTON QTY** ..... 4
- STD ORDER QTY** ..... 4

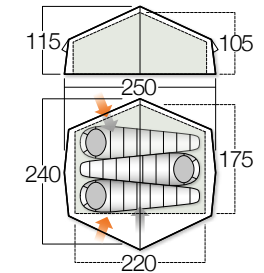

## OPTIONAL ADDITIONS



### FOOTPRINT

- 100 FPNNEVIS S0Y077
- 200 FPNNEVIS S0Y151
- 300 FPNNEVIS S0Y165



### TREK TARP

PAMIR TPNTREK P32Z05



### BANSHEE GEAR STORE

PAMIR TANBANGSGS P32THJ

# SCAFELL



The Scaffell tunnel tent has identical poles for quick and simple pitching. This lightweight tent is designed to perform in a wide range of weather conditions. Recommended by the DofE, the Scaffell is an ideal option for those looking to keep weight and pack size minimal. Built for hiking in the wilds it also features TBS® II and Gothic Arch poles, which add stability, increase the run off of snow and rain and reduce the amount of stress across the poles. A great tent for those with an adventurous spirit.

## SPECIFICATION

**PITCHING**.....All-in-one  
**FLYSHEET**.....Vango Protex® 70 denier polyester flysheet, 3000mm HH  
**INNER**.....Breathable polyester inner  
**GROUND SHEET**.....70D, 6000mm lightweight polyester groundsheet  
**POLES**.....Vango PowerLite 7001-T6 alloy poles

## FEATURES

- Tunnel tent - Style provides greatest space to weight ratio
- Gothic arch pole structure - Increases stability and assists water/snow run-off from the flysheet
- Identical poles - For ease of pitching
- Patented Vango TBS® II Tension Band System increases tent performs in adverse conditions
- O-shaped inner doors - Easy to open with one hand
- Part mesh inner door - Allows ventilation, whilst keeping bugs out
- Flysheet door vent - Open from the top to ventilate porch
- Inner pockets - Conveniently positioned pockets for organising essential items
- Fast pack tent bag - Oversized opening and compression straps to control pack size
- Factory taped seams - All flysheet and groundsheet seams are factory taped, making it watertight
- Weather tested to the European standard EN5912 by certified test centre
- Fly and Groundsheet Only Pitching Option - ideal for lightweight camping



## 200

TENSCAFELP32151

**TRAIL WEIGHT**.....2.08kg  
**TOTAL WEIGHT**.....2.51kg  
**PACKED**.....48 x Ø16cm  
**PITCHING TIME**.....5 mins  
**CARTON QTY**.....4  
**STD ORDER QTY**.....4

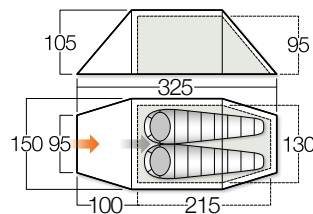

## 300

TENSCAFELP32165

**TRAIL WEIGHT**.....2.48kg  
**TOTAL WEIGHT**.....2.87kg  
**PACKED**.....48 x Ø17cm  
**PITCHING TIME**.....5 mins  
**CARTON QTY**.....4  
**STD ORDER QTY**.....4

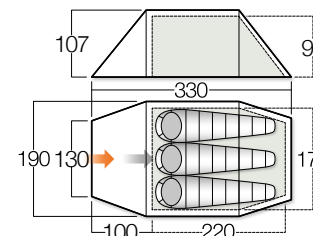

## 300+

TENSCAFELP32210

CORE

**TRAIL WEIGHT**.....3.27kg  
**TOTAL WEIGHT**.....3.57kg  
**PACKED**.....48 x Ø18cm  
**PITCHING TIME**.....7 mins  
**CARTON QTY**.....4  
**STD ORDER QTY**.....4

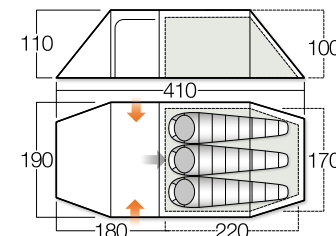

## OPTIONAL ADDITIONS



### FOOTPRINT

100 FPNNEVIS S0Y077  
 200 FPNNEVIS S0Y151  
 300 FPNNEVIS S0Y165



### TREK TARP

PAMIR TPNTREK P32Z05



### TREK GEAR STORE

PAMIR TANTREKGS P32THL



# HELVELLYN NEW

The Vango Helvellyn is a semi geodesic tent, which is ideal for year round trekking, particularly on rougher terrain because of its excellent self-supporting structure. Part of the Vango Experience collection, it is ideal for those where weight and pack size have been kept to a minimum. The Helvellyn benefits from a sizeable interior, including a large front porch area and a multi-functional flysheet door, which allows entry from either side and can be rolled away for a completely open porch. Perfect in all environments, this easy pitch tent is great for wild camps and multi day hikes.

## SPECIFICATION

- PITCHING** .....All-in-one  
**FLYSHEET** ..... Vango Protex® 70 denier polyester flysheet, 3000mm HH  
**INNER** .....Breathable polyester inner  
**GROUNDSHEET** .....70D, 6000mm lightweight polyester groundsheet  
**POLES** ..... Vango PowerLite 7001-T6 alloy poles

## FEATURES

- Semi-geodesic - Self-supporting structure, providing excellent weight and stability balance
- Breathable polyester inner - Allows condensation to pass through, for a comfortable night's sleep
- O-shaped inner doors - Easy to open with one hand
- Part mesh inner door - Allows ventilation, whilst keeping bugs out
- Inner pockets - Conveniently positioned pockets for organising essential items
- Weather tested to the European standard EN5912 by certified test centre
- Fire retardant fabrics - Meets European EN5912 safety standard
- Fast pack tent bag - Oversized opening and compression straps to control pack size
- Factory taped seams - All flysheet and groundsheet seams are factory taped, making it watertight
- Multi function door - entry from either side or can be completely opened



## 200

TENHELVELP32151

- TRAIL WEIGHT** .....2.43kg  
**TOTAL WEIGHT** ..... 2.77kg  
**PACKED** ..... 46 x Ø16cm  
**PITCHING TIME** ..... 10 mins  
**CARTON QTY** ..... 4  
**STD ORDER QTY** ..... 4

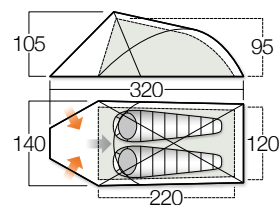

## 300

TENHELVELP32165



- TRAIL WEIGHT** .....3.28kg  
**TOTAL WEIGHT** ..... 3.52kg  
**PACKED** ..... 48 x Ø18cm  
**PITCHING TIME** ..... 10 mins  
**CARTON QTY** ..... 4  
**STD ORDER QTY** ..... 4

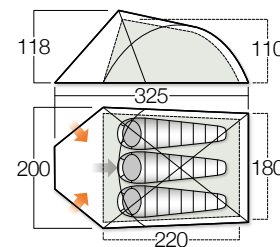

## OPTIONAL ADDITIONS



**FOOTPRINT**  
 100 FPNNEVIS S0Y077  
 200 FPNNEVIS S0Y151  
 300 FPNNEVIS S0Y165



**TREK TARP**  
 PAMIR TPNTREK P32Z05



**TREK GEAR STORE**  
 PAMIR TANTREKGS P32THL



**Yunan Eco Alloy poles**  
robust and stable

**ProTex® 68D 5000mm ripstop polyester**  
strong and waterproof



**Line-Lok guyline runners**  
lock securely, simple release



**O-shaped doors**  
easy to open with one hand

**Breathable polyester inner**  
reduces build up of condensation

## TECHNICAL



**70D lightweight polyester groundsheet**  
6000mm HH



**Part mesh inner door**  
great for ventilation whilst keeping the bugs out

**Porch groundsheet**  
extended groundsheet

## TREK PRO & BASECAMP

The stalwarts of Vango technical tents, these ranges have developed into something of a phenomenon. Combining small pack sizes and low weights with high performance, reliability and strength, these collections are perfect for wild camping and adventures.

**Basecamp** consists of a **70D 190T Polyester flysheet with a 5000mm HH**, a **70D groundsheet with 6000mm HH** and **Vango PowerLite 7001-T6 alloy poles**, with extra head height, these tents are ideal for campsite camping, touring and explorer groups.

**Trek Pro** tents receive an upgraded **68D 190T Ripstop Polyester flysheet**, **70D groundsheet with 6000mm HH** and the incredible **Yunan Eco Alloy poles**, making these tents seriously capable for weekends away on the mountain and longer expeditions alike.



**TECHNICAL**

**BASECAMP**



**GALAXY 300**



**OMEGA 250**



**OMEGA 350**



**OMEGA 500XL**

Part of the Vango Basecamp Series, The Galaxy tent was created after feedback from youth group leaders who wanted space to store gear and hold group meetings, whilst retaining small pack sizes and lighter trek weights. This tent has a large, stand up height front porch and a lower bedroom to keep the user warmer and the pack size and weight down. The clip in riser porch groundsheet allows a clean dry storage area whilst reducing draughts. The Galaxy uses a high-strength flysheet providing greater strength and reliability, ideal for adventurers looking for a bit of extra room but with a good space to weight ratio. Its stability is boosted with TBS®II used on the tunnel structure - perfect for those wild camping in a group or on a weekend away at a campsite!

## SPECIFICATION

**PITCHING** ..... All-in-one  
**FLYSHEET** ..... ProTex® 70D 5000mm hexagonal polyester  
**INNER** ..... Breathable polyester  
**GROUND SHEETS** ..... 70D lightweight polyester 6000mm  
**POLES** ..... PowerLite® 7001-T6 alloy

## FEATURES

- Tunnel tent - Style provides greatest space to weight ratio
- Patented Vango TBS® II Tension Band System increases tent performs in adverse conditions
- Clip-in riser porch groundsheet - Clean, dry storage area for boots and equipment while reducing draughts
- O-shaped inner doors - Easy to open with one hand
- Part mesh inner door - Allows ventilation, whilst keeping bugs out
- Inner pockets - Conveniently positioned pockets for organising essential items
- Diamond Clear Skylight - maximises light into your tent
- Diamond Clear windows - Maximise light and visibility.
- Fast pack tent bag - Oversized opening for easy packing and compression straps to control pack size
- Line-Lok guyline runners - Lock securely, simple to release and high performance in all conditions
- Multiple reflective points - On pegging points for visibility in low light
- Vivid reflective high strength guylines - Provides high visibility in low light
- Factory taped seams - All flysheet and groundsheet seams are factory taped, giving a water tight seal
- Weather tested to the European standard EN5912 by certified test centre



PAMIR  
300 shown

**300** TENGALAXYP32165

**TRAIL WEIGHT** ..... 4.79kg  
**TOTAL WEIGHT** ..... 5.60kg  
**PACKED** ..... 55 x Ø22cm  
**PITCHING TIME** ..... 18 mins  
**CARTON QTY** ..... 2

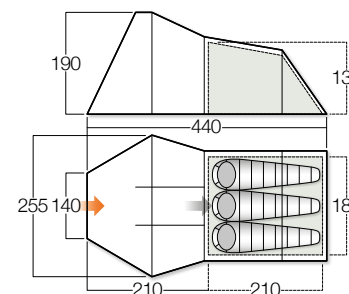

## OPTIONAL ADDITIONS



**FOOTPRINT**  
300 FPNGALAXY SOY165

# OMEGA UPDATED

Part of the Vango Basecamp series, the Omega is a long standing favourite. Ideal for longer expeditions due to the invaluable extra living space, this tent has been designed with larger groups in mind and provides an excellent group space. This base camp tent also features Vango's patented TBS®II Tension Band System, which ensures the tent performs in adverse conditions, particularly in strong, changeable winds. This tent is ideal for those who want to get closer to the outdoors, in comfort and with peace of mind.

## SPECIFICATION

- PITCHING** ..... All-in-one  
**FLYSHEET** ..... ProTex® 70D 5000mm hexagonal polyester  
**INNER** ..... Breathable polyester  
**GROUND SHEETS** ..... 70D lightweight polyester 6000mm  
**POLES** ..... PowerLite® 7001-T6 alloy

## FEATURES

- Tunnel tent - Style provides greatest space to weight ratio
- Mesh flysheet door - full mesh door provides ventilation and keeps bugs out
- Toggled inner divider - Flexible options for sleeping or provides increased living space
- Clip-in riser porch groundsheet - Clean, dry storage area for boots and equipment and reduces draughts
- Diamond Clear windows - Maximise light and visibility.
- Patented Vango TBS®II Tension Band System ensures tent performs in adverse conditions
- Twin flysheet doors - Allows easier access for two or more occupants and/or additional storage
- O-shaped inner doors - Easy to open with one hand
- Part mesh inner door - Allows ventilation, whilst keeping bugs out
- Flysheet door vent - Open from the top to ventilate porch
- Inner pockets - Conveniently positioned pockets for organising essential items
- Fast pack tent bag - Oversized opening and compression straps to control pack size
- Line-Lok guyline runners - Lock securely, simple to release and high performance in all conditions
- Multiple reflective points - On pegging points for visibility in low light
- Vivid reflective high strength guylines - Provides high visibility in low light
- Factory taped seams - All flysheet and groundsheet seams are factory taped, giving a water tight seal
- Weather tested to the European standard EN5912 by certified test centre



## 250

TENOMEGA P32163

- TRAIL WEIGHT** ..... 3.37kg  
**TOTAL WEIGHT** ..... 4.19kg  
**PACKED** ..... 48 x Ø19cm  
**PITCHING TIME** ..... 12 mins  
**CARTON QTY** ..... 2  
**STD ORDER QTY** ..... 2

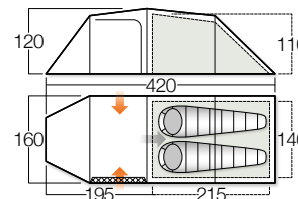

## 350

TENOMEGA P32172

CORE

- TRAIL WEIGHT** ..... 4.32kg  
**TOTAL WEIGHT** ..... 5.15kg  
**PACKED** ..... 48 x Ø20cm  
**PITCHING TIME** ..... 12 mins  
**CARTON QTY** ..... 2  
**STD ORDER QTY** ..... 2

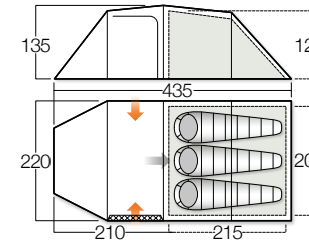

## 500XL

TENOMEGA P32TAP

- TRAIL WEIGHT** ..... 7.86 kg  
**TOTAL WEIGHT** ..... 8.80kg  
**PACKED** ..... 59 x Ø29cm  
**PITCHING TIME** ..... 15 mins  
**CARTON QTY** ..... 2  
**STD ORDER QTY** ..... 2

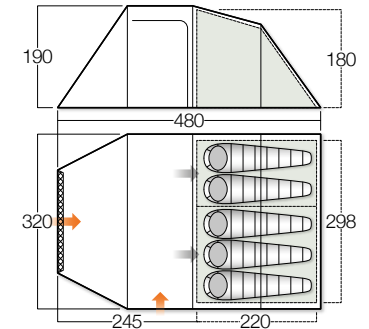

## OPTIONAL ADDITIONS



### FOOTPRINT

250 FPNOMEGA S0Y163  
 350 FPNOMEGA S0Y172  
 500XL FPNOMEGA S0YTAP



### TREK TARP

PAMIR TPNTREK P32Z05



**TECHNICAL**

**TREK PRO**

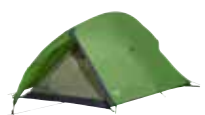

**BLADE PRO 100**



**BLADE PRO 200**



**BANSHEE PRO 200**



**BANSHEE PRO 300**



**TEMPEST PRO 200**



**TEMPEST PRO 300**



**MIRAGE PRO 200**



**MIRAGE PRO 300**



**NEMESIS PRO 300**



**ZENITH PRO 100**



**ZENITH PRO 200**



**ZENITH PRO 300**



**METEOR PRO 200**



**METEOR PRO 300**



**PULSAR PRO 200**



**PULSAR PRO 300**



**HALO PRO 200**



**HALO PRO 300**

# BLADE PRO UPDATED

Blade is a single pole tent, perfect for hiking and multi-day trekking. The compact size and single pole, hoop construction make it simple and quick to pitch tent. The Blade balances great space to weight ratio, with exceptional value for money. But standing still is not an option at Vango and the innovation team have worked hard to bring fresh developments to the Blade, which now has a ripstop flysheet providing greater strength and reliability to this already well designed tent.

## SPECIFICATION

- PITCHING**.....Inner first  
**FLYSHEET**.....ProTex® 68D 5000mm ripstop polyester  
**INNER**.....Breathable polyester  
**GROUNDSHEET**.....70D lightweight polyester 6000mm  
**POLES**.....Yunan Eco Alloy

## FEATURES

- Single pole for quick and simple pitching
- Flysheet door vent - Open from the top to ventilate porch
- Multi-function flysheet door - Open from either side, or roll away completely for an open porch
- Inner pockets - Conveniently positioned pockets for organising essential items
- Fast pack tent bag - Oversized opening for easy packing and compression straps to control pack size
- Line-Lok guyline runners - Lock securely, simple to release and high performance in all conditions
- Multiple reflective points - On pegging points for visibility in low light
- Vivid reflective high strength guylines - Provides high visibility in low light
- Factory taped seams - All flysheet and groundsheet seams are factory taped, giving a water tight seal
- Weather tested to the European standard EN5912 by certified test centre



## 100

TENBLADE P32077

- TRAIL WEIGHT**.....1.63kg  
**TOTAL WEIGHT**.....1.82kg  
**PACKED**.....47 x Ø11cm  
**PITCHING TIME**.....8 mins  
**CARTON QTY**.....6  
**STD ORDER QTY**.....6

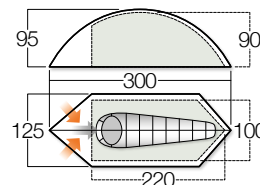

## 200

TENBLADE P32151

- TRAIL WEIGHT**.....1.91kg  
**TOTAL WEIGHT**.....2.10kg  
**PACKED**.....47 x Ø12cm  
**PITCHING TIME**.....8 mins  
**CARTON QTY**.....6  
**STD ORDER QTY**.....6

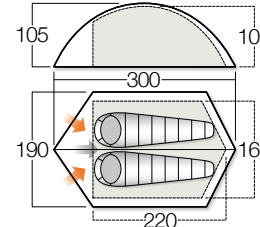

## OPTIONAL ADDITIONS



**FOOTPRINT**  
 100 FPNBLADE S0Y077  
 200 FPNBLADE S0Y151



**TREK TARP**  
 PAMIR TPNTREK P32Z05

# BANSHEE PRO UPDATED

A Vango institution, the Banshee balances pack weight, pack size and living space perfectly, to provide a fantastic trekking and wild camping tent. But standing still is not an option at Vango and the innovation team have worked hard to bring fresh developments to the Banshee, which now has a ripstop flysheet providing greater strength and reliability to this already well designed tent.

## SPECIFICATION

**PITCHING** ..... All-in-one  
**FLYSHEET** ..... ProTex® 68D 5000mm ripstop polyester  
**INNER** ..... Breathable polyester  
**GROUND SHEET** ..... 70D lightweight polyester 6000mm  
**POLES** ..... Yunan Eco Alloy

## FEATURES

- Tunnel tent - Style provides greatest space to weight ratio
- Pre-angled poles - Achieve greater internal space than with a standard curve
- Patented Vango TBS® II Tension Band System increases tent performs in adverse conditions
- Walking pole attachment eyelet in door - Prop up the door with a walking pole to create a sheltered porch
- Twin flysheet doors - Allows easier access for two or more occupants, and/or additional storage
- Flysheet door vent - Open from the top to ventilate porch
- Inner pockets - Conveniently positioned pockets for organising essential items
- Fast pack tent bag - Oversized opening for easy packing and compression straps to control pack size
- Line-Lok guyline runners - Lock securely, simple to release and high performance in all conditions
- Multiple reflective points - On pegging points for visibility in low light
- Vivid reflective high strength guylines - Provides high visibility in low light
- Factory taped seams - All flysheet and groundsheet seams are factory taped, giving a water tight seal
- Weather tested to the European standard EN5912 by certified test centre



**200** TENBANSHEP32151 CORE  
**TRAIL WEIGHT** ..... 2.14kg  
**TOTAL WEIGHT** ..... 2.40kg  
**PACKED** ..... 46 x Ø16cm  
**PITCHING TIME** ..... 7 mins  
**CARTON QTY** ..... 4

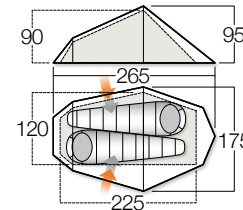

**300** TENBANSHEP32165 CORE  
**TRAIL WEIGHT** ..... 2.55kg  
**TOTAL WEIGHT** ..... 2.80kg  
**PACKED** ..... 46 x Ø17cm  
**PITCHING TIME** ..... 7 mins  
**CARTON QTY** ..... 4

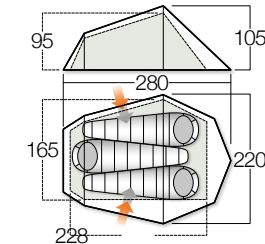

## OPTIONAL ADDITIONS



**FOOTPRINT**  
 200 FPNBANSHE SOY151  
 300 FPNBANSHE SOY165



**TREK TARP**  
 PAMIR TPNTRK P32Z05



**BANSHEE GEAR STORE**  
 PAMIR TANBANSGS P32THJ



# TEMPEST PRO UPDATED



A core model in the Vango trekking range, Tempest is ideal for wild camping and multiday trekking. Its brilliantly designed Venturi Vent System creates a more comfortable environment by reducing the build-up of condensation. Already a great tent, the Tempest has been upgraded to include a ripstop flysheet, which delivers greater strength and reliability to the fabric. The feature packed Tempest hiking tent balances top quality design, with refined engineering construction, to make it one of the best performing tents around.

## SPECIFICATION

- PITCHING** ..... All-in-one
- FLYSHEET** ..... ProTex® 68D 5000mm ripstop polyester
- INNER** ..... Breathable polyester
- GROUNDSHEETS** ..... 70D lightweight polyester 6000mm
- POLES** ..... Yunan Eco Alloy

## FEATURES

- Tunnel tent - Style provides greatest space to weight ratio
- Venturi Vent System - air flow creates a more comfortable environment by reducing condensation
- Patented Vango TBS® II Tension Band System increases tent performs in adverse conditions
- Porch groundsheet - Clean, dry storage area for boots and equipment
- Rain stop flysheet doors - Structured so that rain will not drop into the inner when opened
- O-shaped inner doors - Easy to open with one hand
- Part mesh inner door - Allows ventilation, whilst keeping bugs out
- Flysheet door vent - Open from the top to ventilate porch
- Inner pockets - Conveniently positioned pockets for organising essential items
- Fast pack tent bag - Oversized opening for easy packing and compression straps to control pack size
- Line-Lok guyline runners - Lock securely, simple to release and high performance in all conditions
- Multiple reflective points - On pegging points for visibility in low light
- Vivid reflective high strength guylines - Provides high visibility in low light
- Factory taped seams - All flysheet and groundsheet seams are factory taped, giving a water tight seal
- Weather tested to the European standard EN5912 by certified test centre



PAMIR  
300 shown

**200** TENTEMPESP32151 CORE

**TRAIL WEIGHT** ..... 2.50kg  
**TOTAL WEIGHT** ..... 2.85kg  
**PACKED** ..... 46 x Ø17cm  
**PITCHING TIME** ..... 10 mins  
**CARTON QTY** ..... 4  
**STD ORDER QTY** ..... 4

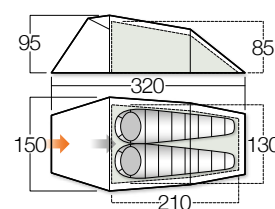

**300** TENTEMPESP32165 CORE

**TRAIL WEIGHT** ..... 3.06kg  
**TOTAL WEIGHT** ..... 3.32kg  
**PACKED** ..... 52 x Ø19m  
**PITCHING TIME** ..... 10 mins  
**CARTON QTY** ..... 4  
**STD ORDER QTY** ..... 4

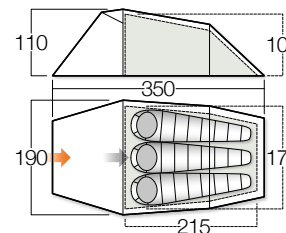

## OPTIONAL ADDITIONS



**FOOTPRINT**  
 200 FPNTEMPES SOY151  
 300 FPNTEMPES SOY165



**TREK TARP**  
 PAMIR TPNTREK P32Z05



**TREK GEAR STORE**  
 PAMIR TANTREKGS P32THL

# MIRAGE PRO



The Vango Mirage is a semi geodesic tent which makes it ideal for pitching on hard ground and rough terrain because of its self-supporting, freestanding structure. This design also makes it very stable in harsh weather conditions to provide reliable shelter from the elements. Whilst the Mirage is a long standing classic of the Vango hiking range, the technical team never stop innovating and brought some improvements to the tent by introducing a ripstop flysheet, which delivers greater strength and reliability to the fabric. The Mirage benefits from a sizable interior including a large front porch with its own groundsheet and a multi functional flysheet door allowing access from either side or to roll away completely for an open porch.

## SPECIFICATION

**PITCHING** ..... All-in-one  
**FLYSHEET** ..... ProTex® 68D 5000mm ripstop polyester  
**INNER** ..... Breathable polyester  
**GROUND SHEETS** ..... 70D lightweight polyester 6000mm  
**POLES** ..... Yunan Eco Alloy

## FEATURES

- Revised shape - maximum headroom where you need it most, at porch and front of inner
- Semi-geodesic - Self-supporting structure, providing excellent balance between weight and stability
- Gothic arch pole structure - Increases stability and assists water/snow run-off from the flysheet
- O-shaped inner doors - Easy to open with one hand
- Part mesh inner door - Allows ventilation, whilst keeping bugs out
- Flysheet door vent - Open from the top to ventilate porch
- Multi-function flysheet door - Open from either side, or roll away completely for an open porch
- Inner pockets - Conveniently positioned pockets for organising essential items
- Fast pack tent bag - Oversized opening for easy packing and compression straps to control pack size
- Line-Lok guyline runners - Lock securely, simple to release and high performance in all conditions
- Multiple reflective points - On pegging points for visibility in low light
- Vivid reflective high strength guylines - Provides high visibility in low light
- Factory taped seams - All flysheet and groundsheet seams are factory taped, giving a water tight seal
- Weather tested to the European standard EN5912 by certified test centre



## 200

TENMIRAGEP32151

**TRAIL WEIGHT** ..... 3.02kg  
**TOTAL WEIGHT** ..... 2.68kg  
**PACKED** ..... 48 x Ø16cm  
**PITCHING TIME** ..... 12 mins  
**CARTON QTY** ..... 4  
**STD ORDER QTY** ..... 4

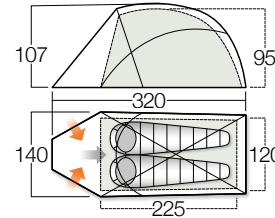

## 300

TENMIRAGEP32165



**TRAIL WEIGHT** ..... 3.38kg  
**TOTAL WEIGHT** ..... 3.62kg  
**PACKED** ..... 48 x Ø18cm  
**PITCHING TIME** ..... 12 mins  
**CARTON QTY** ..... 4  
**STD ORDER QTY** ..... 4

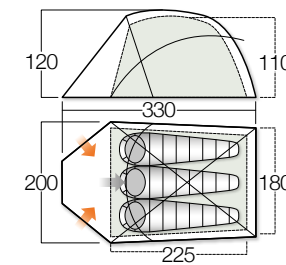

## OPTIONAL ADDITIONS



**FOOTPRINT**  
 200 FPNMIRAGE S0Y151  
 300 FPNMIRAGE S0Y165



**TREK TARP**  
 PAMIR TPNTREK P32Z05

# NEMESIS PRO UPDATED

The Nemesis Pro is a classic geodesic construction with 5 crossover nodes for free standing all-season stability, increased further by the use of Gothic Arch poles on the porch structure. Designed specifically for winter camping and adverse weather conditions, however is ideal for explorers looking for an incredibly stable shelter. Already an extremely effective model, the technical design team felt that the Nemesis could be improved and have opted to include a ripstop flysheet, which delivers greater strength and reliability to the fabric. This tent is highly versatile when pitched, with 2 porch areas for gear storage and dual entry. Additional options are available for the Nemesis such as the Vango Trek Tarp and Vango Gear Store in increase space and allow customisation for your trips.

## SPECIFICATION

**PITCHING** .....All-in-one  
**FLYSHEET** .....ProTex® 68D 5000mm ripstop polyester  
**INNER** ..... Breathable polyester  
**GROUNDSHEET** ..... 70D lightweight polyester 6000mm  
**POLES** .....Yunan Eco Alloy

## FEATURES

- Geodesic - Self-supporting structure, providing excellent balance between weight and stability
- Gothic arch pole structure - Increases stability and assists water/snow run-off from the flysheet
- Rain stop flysheet doors - Structured so that rain will not drop into the inner when opened
- Twin flysheet doors - Allows easier access for two or more occupants, and/or additional storage
- O-shaped inner doors - Easy to open with one hand
- Part mesh inner door - Allows ventilation, whilst keeping bugs out
- Flysheet door vent - Open from the top to ventilate porch
- Multi-function flysheet door - Open from either side, or roll away completely for an open porch
- Inner pockets - Conveniently positioned pockets for organising essential items
- High level pockets - Ideal for storage or to position a torch for light
- Small welded windows - Survey the area and weather conditions from inside your tent
- Fast pack tent bag - Oversized opening and compression straps to control pack size
- Line-Lok guyline runners - Lock securely, simple to release and high performance in all conditions
- Multiple reflective points - On pegging points for visibility in low light
- Vivid reflective high strength guylines - Provides high visibility in low light
- Factory taped seams - All flysheet and groundsheet seams are factory taped, making it watertight
- Weather tested to the European standard EN5912 by certified test centre



PAMIR  
300 shown

## 300

TENNEMESIP32165

**TRAIL WEIGHT** .....4.02kg  
**TOTAL WEIGHT** ..... 4.28kg  
**PACKED** ..... 47 x Ø17cm  
**PITCHING TIME** ..... 15 mins  
**CARTON QTY** ..... 4  
**STD ORDER QTY** ..... 4

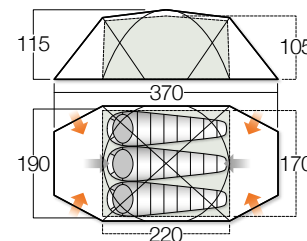

## OPTIONAL ADDITIONS



**FOOTPRINT**  
300 FPNEMESI S0Y165



**TREK TARP**  
PAMIR TPNTREK P32Z05

# ZENITH PRO UPDATED

The Zenith is perfect for those backpacking and trekking, utilising a lightweight, single hooped design which features TBS® II system for extra stability. The tent is pitched all in one and therefore very quick and easy to erect and there is no need to unhook the inner tent when it comes to striking. The flysheet is a super strong ripstop polyester, providing peace of mind and longevity.

## SPECIFICATION

**PITCHING**.....All-in-one  
**FLYSHEET**.....ProTex® 68D 5000mm ripstop polyester  
**INNER**.....Breathable polyester  
**GROUND SHEET**.....70D lightweight polyester 6000mm  
**POLES**.....Yunan Eco Alloy

## FEATURES

- Hybrid tunnel tent - Maximising inner space to weight ratio
- Patented Vango TBS® II Tension Band System increases tent performs in adverse conditions
- Walking pole eyelet in door - Prop up the door with a walking pole to create a sheltered porch
- Rain stop flysheet doors - Structured so that rain will not drop into the inner when opened
- O-shaped inner doors - Easy to open with one hand
- Part mesh inner door - Allows ventilation, whilst keeping bugs out
- Flysheet door vent - Open from the top to ventilate porch
- Inner pockets - Conveniently positioned pockets for organising essential items
- Fast pack tent bag - Oversized opening and compression straps to control pack size
- Line-Lok guyline runners - Lock securely, simple to release and high performance in all conditions
- Multiple reflective points - On pegging points for visibility in low light
- Vivid reflective high strength guylines - Provides high visibility in low light
- Factory taped seams - All flysheet and groundsheet seams are factory taped, making it water tight



ANTHRACITE  
200 shown

## 100 TENZENITHA07077

**TRAIL WEIGHT**.....1.55kg  
**TOTAL WEIGHT**.....1.76kg  
**PACKED**.....35 x Ø13cm  
**PITCHING TIME**.....7 mins  
**CARTON QTY**.....6  
**STD ORDER QTY**.....6

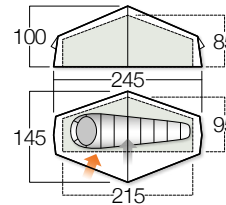

## 200 TENZENITHA07151

**TRAIL WEIGHT**.....1.99kg  
**TOTAL WEIGHT**.....2.2kg  
**PACKED**.....45 x Ø12cm  
**PITCHING TIME**.....7 mins  
**CARTON QTY**.....6  
**STD ORDER QTY**.....6

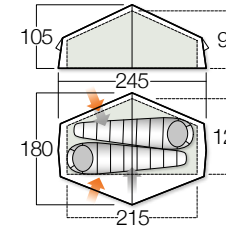

## 300 TENZENITHA07165

**TRAIL WEIGHT**.....2.37kg  
**TOTAL WEIGHT**.....2.58kg  
**PACKED**.....47 x Ø15cm  
**PITCHING TIME**.....7 mins  
**CARTON QTY**.....6  
**STD ORDER QTY**.....6

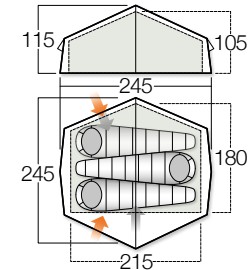

## OPTIONAL ADDITIONS



### FOOTPRINT

100 FPNZENITH S0Y077  
 200 FPNZENITH S0Y151  
 300 FPNZENITH S0Y165



### TREK TARP

ANTHRACITE TPNTREK A07Z05



### BANSHEE GEAR STORE

ANTHRACITE TANBANSGS A07THJ

# METEOR PRO UPDATED

The Meteor tunnel tent is designed with 2 identical poles for quick and easy pitching. Meteor is perfect for those seeking a tent designed to perform in a wide range of weather condition, that is also lightweight and has a small pack weight/ size. Never standing still, the Vango design team have made improvements to the Meteor by introducing a ripstop flysheet, which provides greater strength and reliability to this already well designed hiking tent. This trekking tent also features TBS®II and Gothic Arch poles, which add stability, increase the run off for snow and rain and reduce the amount of stress across the poles. Ideal for wild camps and longer back packing expeditions due to the impressive space to weight ratio.

## SPECIFICATION

**PITCHING** .....All-in-one  
**FLYSHEET** .....ProTex® 68D 5000mm ripstop polyester  
**INNER** ..... Breathable polyester  
**GROUNDSHEETS** .....70D lightweight polyester 6000mm  
**POLES** .....Yunan Eco Alloy

## FEATURES

- Tunnel tent - Style provides greatest space to weight ratio
- Gothic arch pole structure - Increases stability and assists water/snow run-off from the flysheet
- Identical poles - For ease of pitching
- Fly and Groundsheet Only Pitching Option - ideal for lightweight camping
- Breathable polyester inner - Allows condensation to pass through, for a comfortable night's sleep
- Patented Vango TBS®II Tension Band System ensures tent performs in adverse conditions
- Rain stop flysheet doors - Structured so that rain will not drop into the inner when opened
- O-shaped inner doors - Easy to open with one hand
- Part mesh inner door - Allows ventilation, whilst keeping bugs out
- Flysheet door vent - Open from the top to ventilate porch
- Inner pockets - Conveniently positioned pockets for organising essential items
- Fast pack tent bag - Oversized openin and compression straps to control pack size
- Line-Lok guyline runners - Lock securely, simple to release and high performance in all conditions
- Multiple reflective points - On pegging points for visibility in low light
- Vivid reflective high strength guylines - Provides high visibility in low light
- Factory taped seams - All flysheet and groundsheet seams are factory taped, making it water tight
- Weather tested to the European standard EN5912 by certified test centre



**200** TENMETEORA07151  
**TRAIL WEIGHT** .....2.23kg  
**TOTAL WEIGHT** .....2.66kg  
**PACKED** ..... 43 x Ø15cm  
**PITCHING TIME** ..... 7 mins  
**CARTON QTY** ..... 4  
**STD ORDER QTY** ..... 4

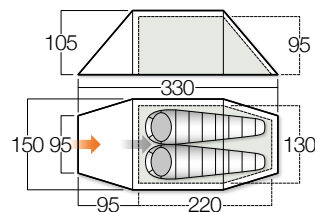

**300** TENMETEORA07165  
**TRAIL WEIGHT** .....2.79kg  
**TOTAL WEIGHT** .....2.94kg  
**PACKED** ..... 50 x Ø15cm  
**PITCHING TIME** ..... 7 mins  
**CARTON QTY** ..... 4  
**STD ORDER QTY** ..... 4

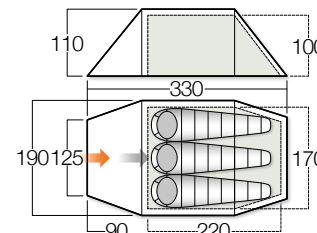

## OPTIONAL ADDITIONS



**FOOTPRINT**  
 200 FPNMETEOR SOY151  
 300 FPNMETEOR SOY165



**TREK TARP**  
 ANTHRACITE TPNTREK AO7Z05

# PULSAR PRO UPDATED

The Pulsar trekking tent is a three poled tunnel tent ideal for gear intensive activities such as kayaking or cycle touring, whilst still being light enough for trekking. The large porch area, which has entry doors on both either sides, includes a porch groundsheet. A favourite feature is the gothic arch pole system, which has three main benefits, firstly it stops water or snow from gathering on the top of the tent, secondly it stops the wind from flexing the poles out of shape, and thirdly it reduces the amount of stress on the poles. The, already brilliant, Pulsar has been upgraded to include a ripstop flysheet, which delivers greater strength and reliability to the fabric. All this, coupled with Vango's TBS®II, creates an extremely robust light weight hiking tent.

## SPECIFICATION

**PITCHING** ..... All-in-one  
**FLYSHEET** ..... ProTex® 68D 5000mm ripstop polyester  
**INNER** ..... Breathable polyester  
**GROUND SHEETS** ..... 70D lightweight polyester 6000mm  
**POLES** ..... Yunan Eco Alloy

## FEATURES

- Tunnel tent - Style provides greatest space to weight ratio
- Gothic arch pole structure - Increases stability and assists water/snow run-off from the flysheet
- Patented Vango TBS® II Tension Band System increases tent performs in adverse conditions
- Porch groundsheet - Clean, dry storage area for boots and equipment
- Rain stop flysheet doors - Structured so that rain will not drop into the inner when opened
- Twin flysheet doors - Allows easier access for two or more occupants, and/or additional storage
- O-shaped inner doors - Easy to open with one hand
- Part mesh inner door - Allows ventilation, whilst keeping bugs out
- Flysheet door vent - Open from the top to ventilate porch
- Inner pockets - Conveniently positioned pockets for organising essential items
- Fast pack tent bag - Oversized opening and compression straps to control pack size
- Line-Lok guyline runners - Lock securely, simple to release and high performance in all conditions
- Multiple reflective points - On pegging points for visibility in low light
- Vivid reflective high strength guylines - Provides high visibility in low light
- Factory taped seams - All flysheet and groundsheet seams are factory taped, making it water tight

## OPTIONAL ADDITIONS



**FOOTPRINT**  
 200 FPNPULSAR SOY151  
 300 FPNPULSAR SOY165



**TREK TARP**  
 ANTHRACITE TPNTREK AO7Z05  
 PAMIR TPNTREK P32Z05



**PAMIR**  
 300 shown

**ANTHRACITE**  
 200 shown

**200** TENPULSARA07151 ●  
**TRAIL WEIGHT** ..... 2.92kg  
**TOTAL WEIGHT** ..... 3.42kg  
**PACKED** ..... 48 x Ø16cm  
**PITCHING TIME** ..... 12 mins  
**CARTON QTY** ..... 4  
**STD ORDER QTY** ..... 4

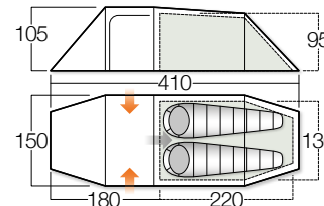

**300** TENPULSARP32165 ● TENPULSARA07165 ● **CORE**  
**TRAIL WEIGHT** ..... 3.57kg  
**TOTAL WEIGHT** ..... 3.87kg  
**PACKED** ..... 48 x Ø17cm  
**PITCHING TIME** ..... 12 mins  
**CARTON QTY** ..... 4  
**STD ORDER QTY** ..... 4

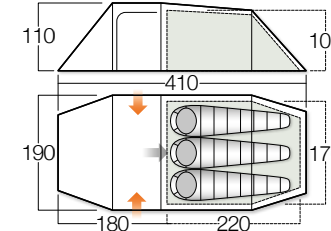

# HALO PRO

Designed to be simple to use by all, the Halo offers a rock-solid semi geodesic structure with three identical length poles. The Halo is known for its large living and porch space as well as the two large doors which create additional flexibility. It has been given a ripstop flysheet which provides greater strength and reliability to this already well constructed tent. This trekking tent is perfect for group camping on a campsite and longer wild camping expeditions.

## SPECIFICATION

**PITCHING** ..... All-in-one  
**FLYSHEET** ..... ProTex® 68D 5000mm ripstop polyester  
**INNER** ..... Breathable polyester  
**GROUND SHEETS** ..... 70D lightweight polyester 6000mm  
**POLES** ..... Yunan Eco Alloy

## FEATURES

- Semi-geodesic - Self-supporting structure, providing excellent balance between weight and stability
- Identical poles - For ease of pitching
- Porch groundsheet - Clean, dry storage area for boots and equipment
- Twin flysheet doors - Allows easier access for two or more occupants and/or additional storage
- O-shaped inner doors - Easy to open with one hand
- Part mesh inner door - Allows ventilation, whilst keeping bugs out
- Flysheet door vent - Open from the top to ventilate porch
- Inner pockets - Conveniently positioned pockets for organising essential items
- Fast pack tent bag - Oversized opening and compression straps to control pack size
- Line-Lok guyline runners - Lock securely, simple to release and high performance in all conditions
- Multiple reflective points - On pegging points for visibility in low light
- Vivid reflective high strength guylines - Provides high visibility in low light
- Factory taped seams - All flysheet and groundsheet seams are factory taped, making it water tight
- Weather tested to the European standard EN5912 by certified test centre



### 200 TENHALO A07151

**TRAIL WEIGHT** ..... 3.26kg  
**TOTAL WEIGHT** ..... 3.66kg  
**PACKED** ..... 48 x Ø19cm  
**PITCHING TIME** ..... 12 mins  
**CARTON QTY** ..... 4

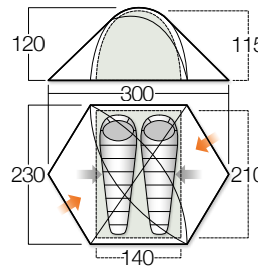

### 300 TENHALO P32165 TENHALO A07165

**TRAIL WEIGHT** ..... 3.81kg  
**TOTAL WEIGHT** ..... 4.21kg  
**PACKED** ..... 50 x Ø21cm  
**PITCHING TIME** ..... 12 mins  
**CARTON QTY** ..... 4

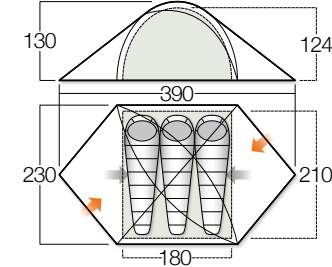

## OPTIONAL ADDITIONS



**FOOTPRINT**  
 200 FPNHALO S0Y151  
 300 FPNHALO S0Y165

# TECHNICAL ADDITIONS

## BANSHEE GEAR STORE

Designed to increase the space of the side-entry style trekking tent. The Banshee Gear Store allows multi-night expeditions to be a little more comfortable, adding storage space or simply extending the living space.

- ProTex® 68D 5000mm ripstop polyester
- Fast pack tent bag.
- Fire retardant fabrics.
- Flysheet door vent.
- Line-Lok guyline runners.
- Multiple reflective points.
- Reflective high strength guylines.
- Vango PowerLite 7001-T6 alloy poles.

**WEIGHT** 760g

**PACKED** 44 x Ø8cm

**CARTON QTY** 4



ANTHRACITE  
TANBANSGSA07THJ

● PAMIR TANBANSGSP32THJ

## TREK TARP

A lightweight addition to extend the storage and living space. Quick and easy to erect, the tarp fits both front and side entry trekking tents.

- ProTex® 68D 5000mm ripstop polyester
- PowerLite 7001-T6 alloy pole.
- Reflective high strength guylines.
- Fire retardant fabric.
- Supplied in carry bag.

**WEIGHT** 760g

**PACKED** 44 x Ø8cm

**CARTON QTY** 4



PAMIR  
TPNTREK P32Z05

● ANTHRACITE TPNTREK A07Z05



## REPLACEMENT FASTPACK BAG

The Vango FastPack Bag is ideal for all of the Vango technical and adventure tents with its oversized opening and compression straps to control pack size.

### SMALL

**WEIGHT** 110g / **PACKED** 45 x Ø15cm  
**CARTON QTY** 1

### MEDIUM

**WEIGHT** 120g / **PACKED** 50 x Ø19cm  
**CARTON QTY** 1

### LARGE

**WEIGHT** 130g / **PACKED** 60 x Ø25cm  
**CARTON QTY** 1

### EXTRA LARGE

**WEIGHT** 150g / **PACKED** 73x Ø30cm  
**CARTON QTY** 1

## GEAR STORE

Designed to increase the space of front-entry style trekking tents. The Trek Gear Store allows multi night expeditions to be a little more comfortable, adding storage space or simply extending the living area.

- ProTex® 70D 5,000mm polyester.
- Vango PowerLite 7001-T6 alloy poles.
- Gothic arch pole structure.
- Multi-function door.
- Flysheet door vent.
- Line-Lok guyline runners.
- Orange reflective high strength guylines.
- Fast pack tent bag.
- Fire retardant fabrics.
- Flexible fit pegging points.

**WEIGHT** 1.71kg

**PACKED** 47 x Ø14cm

**CARTON QTY** 4



PAMIR  
TANTREKGSP32THL

## STORM SHELTER

**200** TEMSTORM007151

**CAPACITY** ..... 2 person

**WEIGHT** ..... 440g

**PACKED** ..... 18 x Ø12cm

**CARTON QTY** ..... 4

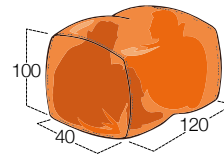

**400** TEMSTORM007151

**CAPACITY** ..... 4 person

**WEIGHT** ..... 700g

**PACKED** ..... 22 x Ø15cm

**CARTON QTY** ..... 4

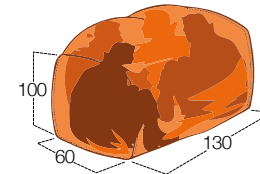

**800** TEMSTORM007151

**CAPACITY** ..... 8 person

**WEIGHT** ..... 1.18kg

**PACKED** ..... 29 x Ø16cm

**CARTON QTY** ..... 4

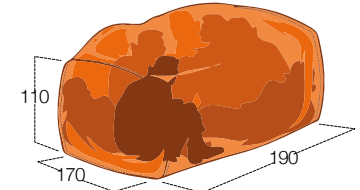





## TECHNICAL

### F10 ALPINE

Drawing from the attributes of the UL & Expedition ranges, the F10 Series Alpine range offers the perfect combination of design, durability and weight for backpacking and mountaineering in the wilderness.

Built to last and withstand adverse weather conditions, the Alpine range of trekking tents is designed to be comfortable and reliable whether your trip is in the rugged Scottish highlands or in the alpine ranges of Europe. Feature rich and highly spec'd this range is the peak of our trekking portfolio and is just waiting to get back out into the mountains.



**TECHNICAL**

**F10 ALPINE RANGE**



**ARÊTE 2**



**EREBUS 2**



**EREBUS 3**



**EREBUS 3+**



**MAKALU 2**

# ARÊTE

NEW

HERO

The Arête has a sharp profile delivering superb stability that will literally slice through strong winds in the wildest of weather conditions whilst boasting remarkably generous headroom. Its ridge and hub pole construction makes it a very quick tent to pitch and is ideal for those trekking over longer distances in multiple locations. There are lots of useful features aimed at providing in field comforts including a gear loft, side storage and efficient ventilation making it ideal for the everyday thrill seeker.

## SPECIFICATION

**PITCHING** ..... Inner first  
**FLYSHEET** ..... 20D 430T Siliconised Ripstop Nylon PU3000mm  
**INNER** ..... 15D 340T Breathable Nylon  
**GROUNDSHEETS** ..... 70D Nylon 6000mm  
**POLES** ..... Yunan Eco Alloy

## FEATURES

- **F10 Series Hub Pole Structure** - Connecting poles at cross over points with F10 Hub. Provides increased pitching efficiency and strength
- **20D ripstop siliconised nylon 5000mm** - Weighing 42 g/m<sup>2</sup>, this is an extremely light, durable and waterproof fabric
- **Yunan Eco Alloy Poles** - Extremely high quality poles made with acid free processing by Yunan
- **Inner first pitching** - Simple and quick to pitch. Allows the tent to be used without the flysheet
- **70D Nylon 6000mm groundsheet** - Highly durable and waterproof
- **15D 28gsm breathable nylon inner tent**
- **O-shaped inner doors** - Easy to open with one hand
- **Flysheet door vent** - Open from the top to ventilate porch
- **Inner pockets** - Conveniently positioned pockets for organising essential items
- **Fast pack tent bag** - Oversized opening and compression straps to control pack size
- **Line-Lok guyline runners** - Lock securely, simple to release and high performance in all conditions
- **Multiple reflective points** - On pegging points for visibility in low light
- **Factory taped seams** - All flysheet and groundsheet seams are factory taped, giving a water tight seal



**2** TENARETE A10002

**TRAIL WEIGHT** ..... 1.25kg

**TOTAL WEIGHT** ..... 1.47kg

**PACKED** ..... 46 x Ø12cm

**PITCHING TIME** ..... 5 mins

**CARTON QTY** ..... 4

**STD ORDER QTY** ..... 1

# EREBUS NEW

Fast and light are the key targets behind the Erebus. Its simple 2 pole tunnel construction not only keeps its trek weight one of the lowest on the market, but also provides a super simple to pitch tent. As with all F10 tunnel tents it is fitted with TBS Pro, which is a patented system that provides highly effective stabilisation in very windy conditions. This combined with its aerodynamic construction makes the Erebus tent the ideal companion for those seeking far flung and remote locations.

## SPECIFICATION

**PITCHING** ..... All-in-one  
**FLYSHEET** ..... 20D 430T Siliconised Ripstop Nylon PU3000mm  
**INNER** ..... 15D 340T Breathable Nylon  
**GROUNDSHEETS** ..... 70D Nylon 6000mm  
**POLES** ..... Yunan Eco Alloy

## FEATURES

- **Tunnel tent** - Style provides greatest space to weight ratio
- **20D ripstop siliconised nylon 5000mm** - Weighing 42 g/m<sup>2</sup>, this is an extremely light, durable and waterproof fabric
- **Yunan Eco Alloy Poles** - Extremely high quality poles made with acid free processing by Yunan. These poles provide excellent strength in high winds as well as being very light.
- **Flysheet and inner pitch together - Quick and easy to pitch and pack**
- **Gothic arch pole structure** - Increases stability and assists water/snow run-off from the flysheet
- **Patented Vango TBS® II Tension Band System** - increases tent performance in adverse conditions, especially in strong, changeable winds
- **70D Nylon 6000mm groundsheet** - Highly durable and waterproof
- **15D 28gsm breathable nylon inner tent**
- **Factory taped seams** - All flysheet and groundsheet seams are factory taped, giving a water tight seal
- **Part mesh inner door** - Allows ventilation, whilst keeping bugs out
- **Rain stop flysheet doors** - Structured so that rain will not drop into the inner when opened
- **O-shaped inner doors** - Easy to open with one hand



### 2 TENEREBUSA10002

**TRAIL WEIGHT** ..... 1.8kg  
**TOTAL WEIGHT** ..... 2.08kg  
**PACKED** ..... 46 x Ø14cm  
**PITCHING TIME** ..... 5 mins  
**CARTON QTY** ..... 4  
**STD ORDER QTY** ..... 1

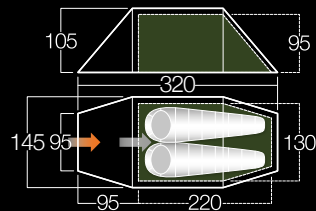

### 3 TENEREBUSA10003

**TRAIL WEIGHT** ..... 2.1kg  
**TOTAL WEIGHT** ..... 2.33kg  
**PACKED** ..... 46 x Ø15cm  
**PITCHING TIME** ..... 5 mins  
**CARTON QTY** ..... 4  
**STD ORDER QTY** ..... 1

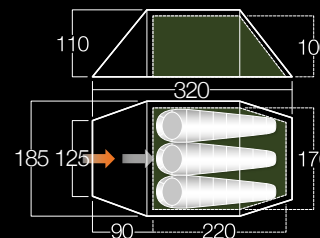

### 3+ TENEREBUSA10TL5

**TRAIL WEIGHT** ..... 2.7kg  
**TOTAL WEIGHT** ..... 3.03kg  
**PACKED** ..... 46 x Ø16cm  
**PITCHING TIME** ..... 7 mins  
**CARTON QTY** ..... 4  
**STD ORDER QTY** ..... 1

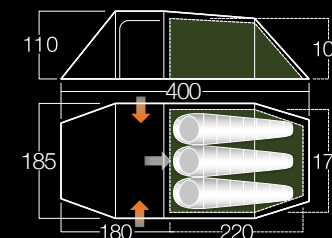

# MAKALU NEW

For those seeking adventure out in the wilds and want to be able to move fast and lightly, the Makalu is superbly suited to provide shelter and security. Its semi geodesic and aerodynamic construction makes pitching on rough terrain more stable and also provides for generous living space for a tent with such a small pack size. There are lots of useful features aimed at providing in field comforts including a gear loft, side storage and efficient ventilation making it ideal for the everyday thrill seeker.

## SPECIFICATION

- PITCHING** ..... All-in-one  
**FLYSHEET** ..... 20D 430T Siliconised Ripstop Nylon PU3000mm  
**INNER** ..... 15D 340T Breathable Nylon  
**GROUNDSHEET** ..... 70D Nylon 6000mm  
**POLES** ..... Yunan Eco Alloy

## FEATURES

- **Semi-geodesic** - Self-supporting structure, providing excellent balance between weight and stability
- **Enhanced inner construction** - water resistant micro-mesh, with strategically placed fabric.
- **Multi-function flysheet door** - open from either side, or roll away completely for an open porch.
- **Flysheet vents with mesh** - increase ventilation and keep bugs out.
- **Rain stop flysheet doors** - structured so that rain will not drop into the inner when opened.
- **Flysheet door vent** - open from the top to ventilate porch.
- **Mesh ceiling storage pocket.**
- **Inner pockets** - conveniently positioned for organising essential items.
- **Line-Lok guyline runners** - lock securely, simple to release.
- **Factory taped seams** - all flysheet and groundsheet seams are factory taped.
- **Multiple reflective points** - for maximum visibility in low light.
- **Reflective high-strength guylines.**
- **FastPack tent bag** - with compression straps and oversized opening.
- **Fire retardant fabrics** - meets European EN5912 safety standard.
- **Weather tested by certified test centre** - to the European standard EN5912.



## 2 TENMAKALUA10002

- TRAIL WEIGHT** ..... 2.25kg  
**TOTAL WEIGHT** ..... 2.47kg  
**PACKED** ..... 48 x Ø15cm  
**PITCHING TIME** ..... 10 mins  
**CARTON QTY** ..... 4  
**STD ORDER QTY** ..... 1

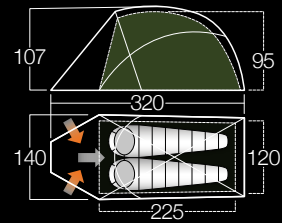



**ProTex® 15D 3000mm  
nylon flysheet**  
silicone/PU coated



**Yunan UL poles**  
pre-angled for effective  
bracing against wind



**Flysheet vents with mesh**  
increase ventilation and keep bugs out

**TECHNICAL**

## **F10 ALPINE LT**

For those who are extremely weight conscious but still want performance and stability. The F10 Series UL range of tents offers an ultra light weight range of shelters to protect you from the elements even in rough weather.

Wrapped in a feather weight 15D siliconised nylon flysheet and water resistant micro-mesh inners these tents are ideal for fast and light expeditions with minimum kit or where weight is a premium on kit intensive activities.

Packed with features such as our light weight TBS® Pro and pre-angled or Gothic arch poles to add stability, plus internal storage and part mesh doors for additional user comfort the UL range of tents offer the perfect light weight package without compromising on usability.



**Breathable nylon inner**  
helps keep the tent fresh



**Dyneema core guylines**  
immense strength-to-weight ratio



**Part mesh inner door**  
helps ventilation and keeps bugs out



**TECHNICAL**

## F10 ALPINE LT RANGE



HELIUM 1



HELIUM 2



XENON 2



XENON 2+

# HELIUM UL HERO

The Helium UL's hybrid tunnel design, ease of pitching and fully taped seams make this lightweight tent a welcome and reliable shelter. TBS® Pro and pre-bend poles offer exceptional stability, and vents allow for a through flow of air reducing any condensation build up. Extremely light weight and a compact pack size make the Helium ideal for short trips without compromising function or performance.

## SPECIFICATION

**PITCHING** ..... All-in-one  
**FLYSHEET** ..... 20D 430T Siliconised Ripstop Nylon PU3000mm  
**INNER** ..... 15D 340T Breathable Nylon  
**GROUNDSHEETS** ..... 70D Nylon 6000mm  
**POLES** ..... Yunan Eco Alloy

## FEATURES

- Main and secondary door - easy entry from either side and useful for kit storage
- Hybrid tunnel tent - maximising inner space to weight ratio
- Pre-angled poles - provides effective bracing against side winds and achieves greater internal space
- TBS® PRO - internal Guying System using an ultra-lightweight dyneema cord
- ProTex® 15D Siliconised & PU Coated Nylon Flysheet - 3000mm
- All flysheet and groundsheet seams are factory taped - Provides watertight seal
- Bathtub groundsheet - Completely waterproof, 10cm base on the inner tent with taped seams
- Yunan SD70 Poles - High quality lightweight poles designed and made by Yunan in Korea
- Breathable inner - reduces build up of condensation and has a ripstop weave for extended durability
- 15D 28gsm breathable nylon inner tent
- O-shaped inner doors - easy to open with one hand
- Part mesh inner door - allows ventilation, whilst keeping bugs out
- Flysheet door vent - Open from the top to ventilate porch
- Internal storage pockets - provides convenient storage within the inner tent
- Flysheet vents with mesh - increases ventilation and keep bugs out
- Fast pack tent bag - oversized opening for easy packing and compression straps to control pack size



### 1 TEMHELIXA10001

**TRAIL WEIGHT** ..... 1.01kg  
**TOTAL WEIGHT** ..... 1.2kg  
**PACKED** ..... 40 x Ø13cm  
**PITCHING TIME** ..... 7 mins  
**CARTON QTY** ..... 4  
**STD ORDER QTY** ..... 1

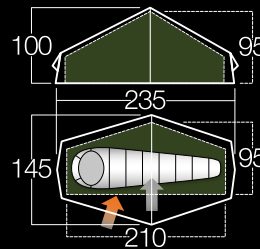

### 2 TEMHELIXA10002

**TRAIL WEIGHT** ..... 1.23kg  
**TOTAL WEIGHT** ..... 1.42kg  
**PACKED** ..... 40 x Ø14cm  
**PITCHING TIME** ..... 7 mins  
**CARTON QTY** ..... 4  
**STD ORDER QTY** ..... 1

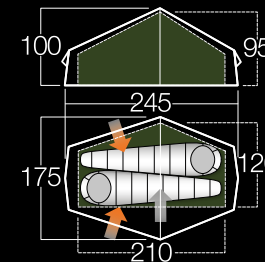



# XENON UL

Xenon Ultralight utilises Gothic Arch poles combined with TBS Pro to create a stable two pole tunnel design which is quick and easy to pitch and strike. Perfect for those seeking greater headroom in the inner tent area, Xenon also features a large vent over the door allowing plenty of airflow, and for UK trips, preventing the rain falling into the inner when the door is open. In a low weight, small pack size, Xenon is a great year round performer.

## SPECIFICATION

**PITCHING** ..... All in one  
**FLYSHEET** ..... ProTex® 15D Siliconised & PU Coated Nylon 3000mm  
**INNER** ..... Water-resistant micro-mesh / breathable polyester  
**GROUND SHEET** ..... 70D lightweight polyester 6000mm  
**POLES** ..... Yunan Eco Alloy

## FEATURES

- **Main and secondary door** - easy entry from either side and useful for kit storage
- **Tunnel tent** - provides greatest space to weight ratio
- **Gothic arch pole structure** - increases stability and assists water/snow run-off from the flysheet
- **TBS® PRO** - internal Guying System using an ultra-lightweight dyneema cord
- **ProTex® 15D Siliconised & PU Coated Nylon Flysheet** - 3000mm
- **All flysheet and groundsheet seams are factory taped** - Provides watertight seal
- **Yunan SD70 Poles** - High quality lightweight poles designed and made by Yunan in Korea
- **Breathable inner** - reduces build up of condensation and has a ripstop weave for extended durability
- **15D 28gsm breathable nylon inner tent**
- **O-shaped inner doors** - easy to open with one hand
- **Part mesh inner door** - allows ventilation, whilst keeping bugs out
- **Flysheet door vent** - Open from the top to ventilate porch
- **Internal storage pockets** - provides convenient storage within the inner tent
- **Flysheet vents with mesh** - increases ventilation and keep bugs out
- **Fast pack tent bag** - oversized opening for easy packing and compression straps to control pack size



**2** TEMXENON A10002  
**TRAIL WEIGHT** ..... 1.9kg  
**TOTAL WEIGHT** ..... 1.64kg  
**PACKED** ..... 45 x Ø16cm  
**PITCHING TIME** ..... 7 mins  
**CARTON QTY** ..... 4  
**STD ORDER QTY** ..... 1

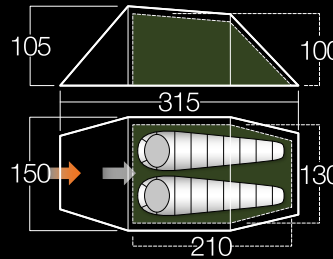

**2+** TEMXENON A10TL4  
**TRAIL WEIGHT** ..... 2.11kg  
**TOTAL WEIGHT** ..... 2.4kg  
**PACKED** ..... 46 x Ø16cm  
**PITCHING TIME** ..... 10 mins  
**CARTON QTY** ..... 4  
**STD ORDER QTY** ..... 1

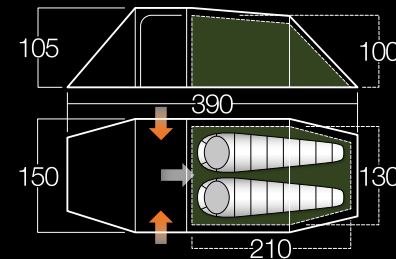



**ProTex® 30D 5000mm ripstop nylon flysheet**  
silicone/PU coated

**Twin flysheet doors**  
easy, flexible access from both sides

**Yunan UL poles**  
pre-angled for effective bracing against wind

*Model shown: MTN 2*



**ProTex® 70D 5000mm ripstop nylon**  
silicone/PU coated

**High strength, reflective guylines**  
maximum visibility in darkness

**Karabiner points**  
strong and conveniently placed for hanging kit

*Model shown: XPD 3*

## TECHNICAL



**Internal pockets**  
conveniently positioned for essentials

**Expedition flysheet doors**  
top half exit - perfect for built up snow and ventilation

**Breathable nylon inner**  
helps keep the tent fresh



**Fully geodesic design**  
incredibly strong structure

**Porch snow valances**  
extra protection for extreme weather conditions

**ProTex® 70D nylon groundsheet**  
6000mm HH

## F10 EXPEDITION

At the absolute pinnacle of technical camping, our Expedition range offers the best kit for extreme usage. Whether your expedition is on a glacier in the alps or the Arctic circle our F10 Series Expedition tents will give you a stable environment to recharge for the next day.

Built on a foundation of functionality and reliability the range embodies the adventurous spirit of its users and their expeditions. Made to stand up to the worst of environments and provide a welcome shelter at the end of the day the MTN and XPD tents are constructed of the best components on the market and designed by active outdoor experts to produce high performance shelters which are at home in the harshest of conditions.



**TECHNICAL**

**F10 EXPEDITION**



**MTN 2**



**XPD 3**

# MTN

We've taken the mountaineer's favoured 4 pole geodesic design, and improved it with our Axial Hub pole system and Vari-Pitch options. The multi award winning MTN 2 is the go to mountain tent for all UK or overseas trips. The ability to pitch inner first, flysheet first with footprint, or flysheet and footprint only, makes this a versatile, free standing shelter especially good for use in adverse weather conditions. Our 30D ripstop Nylon 6.6 Silicon/PU flysheet is light yet robust with fully taped seams. With a dependable 70D Nylon groundsheet and only being 3.42kg, MTN 2 is the new benchmark for mountain tents.

## SPECIFICATION

**PITCHING** ..... Vari-pitch  
**FLYSHEET** ..... 30D ripstop nylon 6.6  
**INNER** ..... Water-resistant micro-mesh / breathable polyester  
**GROUND SHEET** ..... 70D lightweight polyester 6000mm  
**POLES** ..... Yunan

## FEATURES

- **Classic geodesic design** - 5 crossover points for free standing all-season stability
- **Axial Hub pole structure** - Connecting UL Poles at cross over points with Axial Hub. Provides increased pitching efficiency, strength and allows for Vari-Pitch options
- **Cross over pole structure** - Provides free standing tent before being pegged out. Great for hard to peg conditions such as snow, sand and hard ground
- **30D ripstop nylon 6.6** - optimum strength to weight ratio
- **Siliconised/PU Backed** - Siliconised outer coating and polyurethane coated underside for maximum strength and waterproofing
- **PU backed groundsheet with taped seams** - Prevents water ingress
- **All flysheet and groundsheet seams are factory taped** - Provides watertight seal
- **Yunan UL Poles** - High quality ultralite poles designed and made by Yunan in Korea
- **Double-layer inner doors** - zip away the breathable nylon for 100% mesh doors and maximum ventilation
- **Expedition doors** - Exit via top-half of door in built up snow. Good ventilation option
- **Inner tent roof vents** - Zipped ventilation to reduce condensation
- **Internal storage pockets** - Provides convenient storage within the inner tent



**2** TEKMTN A10002

**TRAIL WEIGHT** ..... 3.16kg  
**TOTAL WEIGHT** ..... 3.42kg  
**PACKED** ..... 49 x Ø17cm  
**PITCHING TIME** ..... 8 mins  
**CARTON QTY** ..... 4  
**STD ORDER QTY** ..... 1

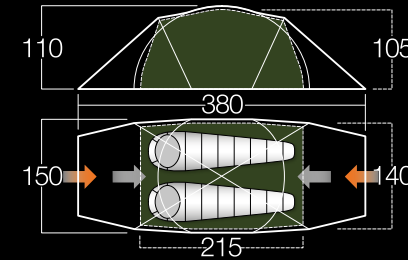

## OPTIONAL ADDITIONS



**FOOTPRINT**  
2 FPNMTN SOY002

# XPD

Having supplied shelter to countless expeditions over the last 50 years, from pioneering Everest trips to recent Himalaya expeditions, we have poured all of our experience and athlete feedback into our latest expedition tent, the XPD. This has culminated in a 3 person, inner first pitch, fully geodesic tent with an added front porch. Utilising Yunan UL poles, and featuring a super durable 70D ripstop Nylon flysheet, expedition doors, gear loops in the inner tent, and the ability to internally guy for extra strength. At just 4.4kg, the XPD 3 sets a new standard for Expedition Tents.

## SPECIFICATION

**PITCHING** ..... Inner first  
**FLYSHEET** ..... 70D Ripstop Nylon 6: 5000mm Siliconised/PU Backed  
**INNER** ..... Breathable nylon  
**GROUND SHEET** ..... ProTex® 70D 6000mm nylon: PU coated  
**POLES** ..... Yunan UL

## FEATURES

- **Full geodesic design** - free standing pole structure. 7 cross over points create an incredibly strong expedition tent
- **Geodesic porch** - front and rear poles cross over the structure creating vestibules that will stand up to bad weather and extend the living and changing area when you need to sit out a storm.
- **Colour coded poles** - for intuitive pitching.
- **Twin flysheet doors** - allows easy, flexible access from both sides.
- **Porch snow valances** - extra protection when extreme weather conditions are expected.
- **Expedition flysheet doors** - exit via top-half of door in built-up snow. Great ventilation option.
- **Factory taped seams** - all flysheet and groundsheet seams are factory taped.
- **Inner tent roof vents** - zipped ventilation increases airflow and helps reduce condensation.
- **Double-layer inner doors** - zip away the outer door for 100% mesh doors.
- **Bathub inner groundsheet** - completely waterproof, 10cm base with taped seams.
- **Inner pockets** - conveniently positioned for organising essential items.
- **Karabiner points** - strong and conveniently placed for hanging lighting or kit.
- **Pre-sewn internal loops** - option to create internal guy system.
- **Duraflex components** - strong and reliable.



**3** TENXPD AB7003

**TRAIL WEIGHT** ..... 4.19kg  
**TOTAL WEIGHT** ..... 4.45kg  
**PACKED** ..... 56 x Ø20cm  
**PITCHING TIME** ..... 12 mins  
**CARTON QTY** ..... 4  
**STD ORDER QTY** ..... 1

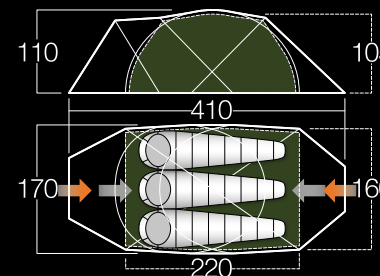

## OPTIONAL ADDITIONS



**FOOTPRINT**  
 3 FPNXPD SOY003



## ADVENTURE TENTS

*From first time users to festival goers to those looking for something a little bit more technical without moving up to a full technical tent. Our Adventure range covers all the bases.*

*Experience meets the needs of our first-time campers, offering a safe and reliable option for those new to the outdoors. With all the reliability, you would expect from a Vango product at an accessible price point this range enables users to get out and experience the wonderful outdoors and enjoy exploring everything that nature has to offer.*

*Adventure continues from previous years with its bright colour ways, low weights and quick pitch times. It's the ideal option for small groups of friends, youngsters and festivals where time is of the essence to pitch and then enjoy.*

*At the top of our new Adventure range sits Adventure AL. The perfect proposition for consumers who wish to upgrade their kit to the next level without making the jump to a technical tent or who want a semi technical package or use their tent to facilitate their activities but are not so concerned about weight.*

### EXPERIENCE

Entry level Adventure tents

### ADVENTURE

Classic adventure tents

### ADVENTURE ALLOY

Lightweight adventure tents

# ADVENTURE TENT RANGE - SPECIFICATION

TENT	FLYSHEET	INNER	GROUNDSHEET	WINDOWS	POLES	ZIPS	PEGS	GUYLINES	BAG	TBS II
<b>Tay</b>	Protex® 70D 190T 3000mm Polyester	70D 190T Breathable	Polyethylene 10,000mm flat	Small Diamond Clear	Vango PowerFlex® Fibreglass Poles	Standard	Steel	High vizibility	Handled carry bag	
<b>Spey</b>	Protex® 70D 190T 3000mm Polyester	70D 190T Breathable	Polyethylene 10,000mm flat	Small Diamond Clear	Vango PowerFlex® Fibreglass Poles	Standard	Steel	High vizibility	Handled carry bag	✓
<b>Spey+</b>	Protex® 70D 190T 3000mm Polyester	70D 190T Breathable	Polyethylene 10,000mm flat	Small Diamond Clear	Vango PowerFlex® Fibreglass Poles	Standard	Steel	High vizibility	Handled carry bag	✓
<b>Skye</b>	Protex® 70D 190T 3000mm Polyester	70D 190T Breathable	Polyethylene 10,000mm linked in	Small Diamond Clear	Vango PowerFlex® Fibreglass Poles	Standard	Steel	High vizibility	Handled carry bag	✓
<b>Soul</b>	Protex® 70D 190T 3000mm Polyester	70D 190T Breathable with part mesh door	Polyethylene 10,000mm	-	Vango PowerFlex® Fibreglass Poles	Standard	Steel	High vizibility	Fastpack bag	
<b>Alpha</b>	Protex® 70D 190T 3000mm Polyester	70D 190T Breathable with part mesh door	Polyethylene 10,000mm linked in	Large Diamond Clear with roll away curtains	Vango PowerFlex® Fibreglass Poles	Standard	Steel	High vizibility	Fastpack bag	
<b>Sigma</b>	Protex® 70D 190T 3000mm Polyester	70D 190T Breathable with part mesh door	Polyethylene 10,000mm linked in	Large Diamond Clear with roll away curtains	Vango PowerFlex® Fibreglass Poles	Standard	Steel	High vizibility	Fastpack bag	
<b>Beta</b>	Protex® 70D 190T 3000mm Polyester	70D 190T Breathable with part mesh door	Polyethylene 10,000mm linked in	Large Diamond Clear with roll away curtains	Vango PowerFlex® Fibreglass Poles	Standard	Steel	High vizibility	Fastpack bag	✓
<b>Zeta Alloy</b>	Protex® 70D 190T 3000mm Polyester	70D 190T Breathable with part mesh door	Polyethylene 10,000mm	-	Vango Powerlite® Alloy Poles	Oversized #10 zips	Oversized steel	High visibility with reflective fleck	Fastpack bag	
<b>Delta Alloy</b>	Protex® 70D 190T 3000mm Polyester	70D 190T Breathable with part mesh door	Polyethylene 10,000mm	-	Vango Powerlite® Alloy Poles	Oversized #10 zips	Oversized steel	High visibility with reflective fleck	Fastpack bag	
<b>Sigma Alloy</b>	Protex® 70D 190T 3000mm Polyester	70D 190T Breathable with part mesh door	Polyethylene 10,000mm linked in	Large Diamond Clear with roll away curtains	Vango Powerlite® Alloy Poles	Oversized #10 zips	Oversized steel	High visibility with reflective fleck	Fastpack bag	
<b>Beta Alloy</b>	Protex® 70D 190T 3000mm Polyester	70D 190T Breathable with part mesh door	Polyethylene 10,000mm linked in	Large Diamond Clear with roll away curtains	Vango Powerlite® Alloy Poles	Oversized #10 zips	Oversized steel	High visibility with reflective fleck	Fastpack bag	✓

# ADVENTURE TENT RANGE - ADDITIONS

TENT	ADVENTURE TARP	TUNNEL TARP	SMALL REPLACEMENT FASTPACK BAG	MEDIUM REPLACEMENT FASTPACK BAG	LARGE REPLACEMENT FASTPACK BAG	X-LARGE REPLACEMENT FASTPACK BAG	ADVENTURE WINDBREAK	3X3 TARP	4X4 TARP
Tay	✓	✗	✗	Tay 200 Only	Tay 300 & 400 Only	✗	✓	✓	✓
Spey	✓	✗	✗	✗	✓	✗	✓	✓	✓
Spey+	✓	✗	✗	✗	✓	✗	✓	✓	✓
Skye	✗	✓	✗	✗	✗	✓	✓	✓	✓
Soul	✓	✗	Soul 100 only	Soul 200 & 300 only	✗	✗	✓	✓	✓
Alpha	✓	✗	✗	Alpha 250 & 300 only	Alpha 400 only	✗	✓	✓	✓
Sigma	✓	✗	✗	✗	✓	✗	✓	✓	✓
Beta	✗	✓	✗	✗	Beta 350XL & 450XL only	Beta 550XL	✓	✓	✓
Zeta Alloy	✓	✗	✗	✓	✗	✗	✓	✓	✓
Delta Alloy	✓	✓	✗	Delta 200 alloy only	Delta 300 alloy only	✗	✓	✓	✓
Sigma Alloy	✓	✗	✗	✗	✓	✗	✓	✓	✓
Beta Alloy	✗	✓	✗	✗	Beta 550XL alloy only	Beta 550XL alloy only	✓	✓	✓





## ADVENTURE

### EXPERIENCE

A new offering for 2018, our Experience collection within the Adventure range has been introduced as the perfect tent proposition for those seeking their first tent to experience camping in the outdoors.

Encompassing all of the quality and reliability our existing consumers trust the Vango brand for, the collection adds user orientated features such as lights out inners, lantern hanging points and porch groundsheets to make the users first time camping a great experience.

Designed to be simple and quick to pitch with colour coded poles; the focus for these tents is on the adventure. Whether that's at a festival or your first time sleeping under the stars on a campsite, we have thought of everything so you don't have to.



**ADVENTURE**

**EXPERIENCE**



TAY 200



TAY 300



TAY 400



SPEY 200



SPEY 300



SPEY 400



SPEY+ 200



SPEY+ 300



SPEY+ 400



SKYE 400



SKYE 500

# TAY NEW

The Tay offers a dome style tent maximising on small pack sizes and added space within the tent. The clear windows allow light to the porch area, while the gothic arch pole provides added strength and stability in adverse weather, as well as extra headroom. The flat groundsheet is easy to clean and roll away, with the lights out bedroom ensuring a sound nights sleep - perfect for a lie in. This is the ideal choice for first time campers or festival goers.

## SPECIFICATION

**PITCHING** ..... Inner first  
**FLYSHEET** ..... ProTex® 70D 3,000mm polyester  
**INNER** ..... Breathable polyester  
**GROUND SHEET** ..... Polyethylene  
**POLES** ..... PowerFlex® fibreglass

## FEATURES

- High Visibility Guylines attached at optimum positions for stability and tension.
- Inner first pitching - Simple and quick to pitch. Allows the tent to be used without the flysheet
- Gothic arch pole structure - Increases stability and assists water run-off from the flysheet
- Integrated eyelets allow optional king poles to prop open doors and create a canopy
- Factory taped seams - flysheet and groundsheet seams are factory taped, making it water tight
- Porch groundsheet - Clean, dry storage area for boots and equipment
- Colour coded poles for intuitive pitching
- Lights out inner tent - Darker fabric reduces the amount of early morning light
- Lantern hanging points - Conveniently positioned in the bedroom areas
- Inner pockets - Conveniently positioned pockets for organising essential items
- Diamond Clear PVC windows for maximum light and great visibility
- Handled carry bag - Provides easy transportation to and from the campsite
- Weather tested to the European standard EN5912 by certified test centre



**200** TENTAY T15151 CORE  
**TOTAL WEIGHT** ..... 3.31kg  
**PACKED** ..... 59 x Ø17cm  
**PITCHING TIME** ..... 10 mins  
**CARTON QTY** ..... 6  
**STD ORDER QTY** ..... 6

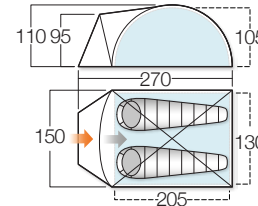

**300** TENTAY T15165 CORE  
**TOTAL WEIGHT** ..... 3.97kg  
**PACKED** ..... 63 x Ø17cm  
**PITCHING TIME** ..... 10 mins  
**CARTON QTY** ..... 4  
**STD ORDER QTY** ..... 4

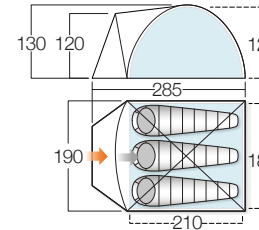

**400** TENTAY T15173  
**TOTAL WEIGHT** ..... 4.79kg  
**PACKED** ..... 70 x Ø18cm  
**PITCHING TIME** ..... 10 mins  
**CARTON QTY** ..... 4  
**STD ORDER QTY** ..... 4

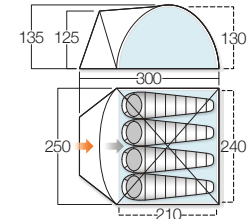

## OPTIONAL ADDITIONS



# SPEY NEW

The Spey is an easy to pitch two-pole tunnel tent, featuring our innovative Gothic Arch poles. This design prevents excessive pole flex in adverse weather conditions, increasing stability, whilst creating additional head height for added comfort. This tent features DiamondClear windows allowing light into the porch area, ideal for storing your kit. The porch area also has an easy to clean, roll away groundsheet. Spey is the perfect choice for new explorers or young couples, heading out on short trips.

## SPECIFICATION

**PITCHING** .....All-in-one  
**FLYSHEET** .....ProTex® 70D 3,000mm polyester  
**INNER** ..... Breathable polyester  
**GROUND SHEET** ..... Polyethylene  
**POLES** .....PowerFlex® fibreglass

## FEATURES

- Patented Vango TBS® II Tension Band System increases tent performs in adverse conditions
- High Visibility Guylines attached at optimum positions for stability and tension
- Gothic arch pole structure - Increases stability and assists water run-off from the flysheet
- Integrated eyelets allow optional king poles to prop open doors and create a canopy
- Factory taped seams - flysheet and groundsheet seams are factory taped, making it water tight
- Porch groundsheet - Clean, dry storage area for boots and equipment
- Colour coded poles for intuitive pitching
- Lights out inner tent - Darker fabric reduces the amount of early morning light
- Lantern hanging points - Conveniently positioned
- Inner pockets - Conveniently positioned pockets for organising essential items
- Diamond Clear PVC windows for maximum light and great visibility
- Handled carry bag - Provides easy transportation to and from the campsite
- Weather tested to the European standard EN5912 by certified test centre

## OPTIONAL ADDITIONS



TREETOPS  
300 shown

**200** TENSPEY T15151  
**TOTAL WEIGHT** ..... 3.2kg  
**PACKED** ..... 55 x Ø17cm  
**PITCHING TIME** ..... 10 mins  
**CARTON QTY** ..... 4  
**STD ORDER QTY** ..... 4

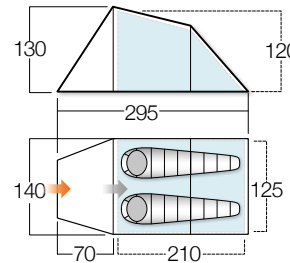

**300** TENSPEY T15165 CORE  
**TOTAL WEIGHT** ..... 4.35kg  
**PACKED** ..... 60 x Ø18cm  
**PITCHING TIME** ..... 10 mins  
**CARTON QTY** ..... 4  
**STD ORDER QTY** ..... 4

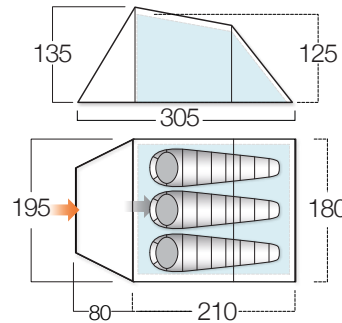

**400** TENSPEY T15173  
**TOTAL WEIGHT** ..... 4.71kg  
**PACKED** ..... 65 x Ø19cm  
**PITCHING TIME** ..... 10 mins  
**CARTON QTY** ..... 4  
**STD ORDER QTY** ..... 4

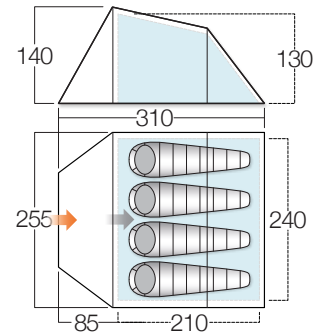

# SPEY+ NEW

Biking, water sports, and extended hiking trips are just some of the activities the Spey+ tent is ideally suited to. Three Gothic Arch poles provide structure and stability, whilst increasing head room. The third pole allowing for a large porch, perfect for storing extended gear or relaxing in. Our lights out bedroom ensures you get a sound sleep, ready for your next day's activity.

## SPECIFICATION

- PITCHING** .....All-in-one
- FLYSHEET** .....ProTex® 70D 3,000mm polyester
- INNER** ..... Breathable polyester
- GROUND SHEET** ..... Polyethylene
- POLES** .....PowerFlex® fibreglass

## FEATURES

- Patented Vango TBS® II Tension Band System increases tent performs in adverse conditions
- High Visibility Guylines attached at optimum positions for stability and tension.
- Gothic arch pole structure - Increases stability and assists water run-off from the flysheet
- Integrated eyelets allow optional king poles to prop open doors and create a canopy
- Factory taped seams - flysheet and groundsheet seams are factory taped, making it water tight
- Porch groundsheet - Clean, dry storage area for boots and equipment
- Colour coded poles for intuitive pitching
- Lights out inner tent - Darker fabric reduces the amount of early morning light
- Lantern hanging points - Conveniently positioned in the living and bedroom areas
- Inner pockets - Conveniently positioned pockets for organising essential items
- Diamond Clear PVC windows for maximum light and great visibility
- Handled carry bag - Provides easy transportation to and from the campsite
- Weather tested to the European standard EN5912 by certified test centre



TREETOPS  
300+ shown

### 200+ TENSPEY T15203

- TOTAL WEIGHT** ..... 4.08kg
- PACKED** ..... 55 x Ø18cm
- PITCHING TIME** ..... 10 mins
- CARTON QTY** ..... 4
- STD ORDER QTY** ..... 4

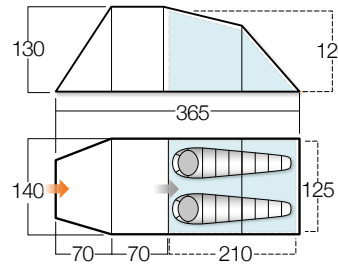

### 300+ TENSPEY T15210



- TOTAL WEIGHT** ..... 5.12kg
- PACKED** ..... 60 x Ø19cm
- PITCHING TIME** ..... 10 mins
- CARTON QTY** ..... 4
- STD ORDER QTY** ..... 4

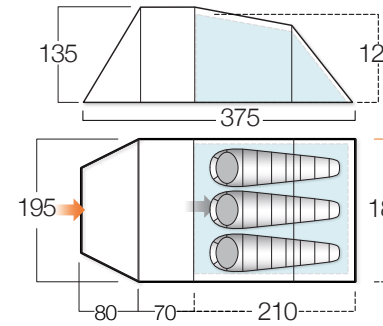

### 400+ TENSPEY T15211



- TOTAL WEIGHT** ..... 6.03kg
- PACKED** ..... 65 x Ø20cm
- PITCHING TIME** ..... 10 mins
- CARTON QTY** ..... 2
- STD ORDER QTY** ..... 2

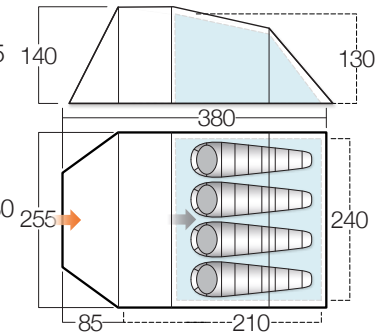

## OPTIONAL ADDITIONS



# SKYE NEW

The Skye features a side entry into the full stand up height living space in an easy-to-pitch three-pole tunnel tent design. DiamondClear windows allow light to pour into the spacious porch area, contrasted with our lights out bedroom area ensuring a darker space for better sleep in the great outdoors. Skye also comes with our patented TBS system, adding stability to the tent in adverse weather conditions. This tent is perfect for small families, couples, friends, weekend camps and festivals.

## SPECIFICATION

**PITCHING** .....All-in-one  
**FLYSHEET** .....ProTex® 70D 3,000mm polyester  
**INNER** ..... Breathable polyester  
**GROUNDSHEET** ..... Linked in Polyethylene  
**POLES** .....PowerFlex® fibreglass

## FEATURES

- High Visibility Guylines attached at optimum positions for stability and tension.
- Diamond Clear PVC windows for maximum light and great visibility
- Tunnel tent - Style provides greatest space to weight ratio
- Patented Vango TBS®II Tension Band System ensures tent performs in adverse conditions
- Linked-in groundsheet - Easy to clean groundsheet that can be attached or detached from the living area. Simply roll under the bedroom area when not required.
- Factory taped seams - flysheet and groundsheet seams are factory taped, making it water tight
- Colour coded poles for intuitive pitching
- Lights out inner tent - Darker fabric reduces the amount of early morning light
- Lantern hanging points - Conveniently positioned in the living and bedroom areas
- Inner pockets - Conveniently positioned pockets for organising essential items
- Handled carry bag - Provides easy transportation to and from the campsite
- Weather tested to the European standard EN5912 by certified test centre



TREETOPS  
400 shown

**400** TENSKEYE T15173 CORE  
**TOTAL WEIGHT** ..... 6.66kg  
**PACKED** ..... 65 x Ø23cm  
**PITCHING TIME** ..... 15 mins  
**CARTON QTY** ..... 2  
**STD ORDER QTY** ..... 2

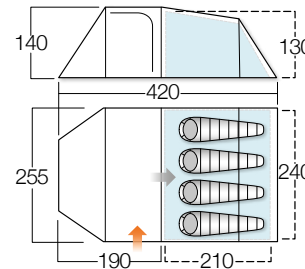

**500** TENSKEYE T15177 HERO CORE  
**TOTAL WEIGHT** ..... 9.33kg  
**PACKED** ..... 70 x Ø25cm  
**PITCHING TIME** ..... 15 mins  
**CARTON QTY** ..... 2  
**STD ORDER QTY** ..... 2

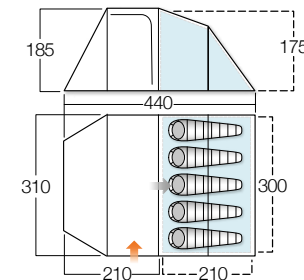

## OPTIONAL ADDITIONS





## ADVENTURE

### ADVENTURE

A firm staple in our range, the classic Adventure range has long been a favourite of youth groups, adventure sports enthusiasts and groups of friends off on weekend trips.

Low weights and small pack sizes make these tents easy to fit in a small car or rucksack and light to carry to the campsite. User orientated features such as Diamond Clear windows, part mesh inner doors and lantern hanging points make camping simple and easy with all of the essentials to hand.

With most of the range pitchable in 10min or less the focus for this range is enhancing your experience on site with more time to socialise and enjoy your adventure. The lights out inner will also allow help you get a lie in to recharge for the next day's activities!



## ADVENTURE

### ADVENTURE



SOUL 100



SOUL 200



SOUL 300



ALPHA 250



ALPHA 300



ALPHA 400



SIGMA 300



SIGMA 300+



BETA 350XL



BETA 450XL



BETA 550XL



# SOUL

UPDATED



The Soul offers an ideal starter tent for those taking their first steps into the world of camping! It can be pitched in under seven minutes thanks to the simple tunnel design and two pole structure, while the fast pack tent bag ensures it's a breeze to pack away. These tents are perfect for adventurers who wish to minimize pitching time and make the most of the great outdoors.

## SPECIFICATION

**PITCHING** ..... Inner first  
**FLYSHEET** ..... ProTex® 70D 3,000mm polyester  
**INNER** ..... Breathable polyester  
**GROUNDSHEET** ..... Polyethylene  
**POLES** ..... PowerFlex® fibreglass

## FEATURES

- Lights out inner tent - Darker fabric reduces the amount of early morning light
- Part mesh inner door - Allows ventilation, whilst keeping bugs out
- Additional ventilation – increases air flow throughout the tent and helps to reduce condensation
- Lantern hanging points - Conveniently positioned
- Inner pockets - Conveniently positioned pockets for organising essential items
- Fast pack tent bag - Oversized opening and compression straps to control pack size
- Reflective webbing - Picks up torchlight so the pegging points are easily spotted in low light
- High visibility guylines - Easy to see in low light conditions
- Weather tested to the European standard EN5912 by certified test centre



**100** TENSOU R19077 ●  
 TENSOU AA8077 ●

**TOTAL WEIGHT** ..... 1.82kg  
**PACKED** ..... 50 x Ø14cm  
**PITCHING TIME** ..... 7 mins  
**CARTON QTY** ..... 6  
**STD ORDER QTY** ..... 6

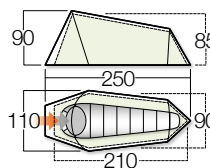

**200** TENSOU R19151 ●  
 TENSOU AA8151 ●

**TOTAL WEIGHT** ..... 2.17kg  
**PACKED** ..... 52 x Ø15cm  
**PITCHING TIME** ..... 7 mins  
**CARTON QTY** ..... 6  
**STD ORDER QTY** ..... 6

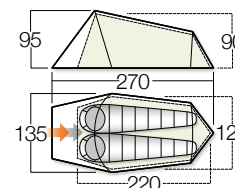

**300** TENSOU R19165 ●  
 TENSOU AA8165 ●

**TOTAL WEIGHT** ..... 2.86kg  
**PACKED** ..... 52 x Ø17cm  
**PITCHING TIME** ..... 7 mins  
**CARTON QTY** ..... 6  
**STD ORDER QTY** ..... 6

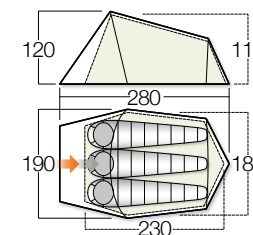

## OPTIONAL ADDITIONS



# ALPHA



Recommended by The Scout Association, the Alpha is an easy-to-pitch tent that features a stylish and functional gothic arch porch pole, plus crystal clear windows to lighten the interior. The stable structure offers generous headroom whilst the waterproof and fire retardant fabrics make this well-ventilated tent an ideal choice for outdoor adventurers, cyclists and groups looking for a small pack size and easy transportation.

## SPECIFICATION

**PITCHING**.....Inner first  
**FLYSHEET**.....ProTex® 70D 3,000mm polyester  
**INNER**.....Breathable polyester  
**GROUND SHEET**.....Polyethylene  
**POLES**.....PowerFlex® fibreglass

## FEATURES

- Gothic arch pole structure - Increases stability and assists water/snow run-off from the flysheet
- Integrated eyelets allow optional king poles to prop open doors. Creates a canopy
- Factory taped seams - All flysheet and groundsheet seams are factory taped, making it watertight
- Linked-in groundsheet - Easy to clean groundsheet that can be attached or detached from the living area. Simply roll under the bedroom area when not required.
- Lights out inner tent - Darker fabric reduces the amount of early morning light
- Part mesh inner door - Allows ventilation, whilst keeping bugs out
- Lantern hanging points - Conveniently positioned in the living and bedroom areas
- Inner pockets - Conveniently positioned pockets for organising essential items
- Diamond Clear windows - Maximise light and visibility.
- Fast pack tent bag - Oversized opening and compression straps to control pack size
- Reflective webbing - Picks up torchlight so the pegging points are easily spotted in low light
- High visibility guylines - Easy to see in low light conditions.
- Weather tested to the European standard EN5912 by certified test centre



**250** TEMALPHA R19163 ●  
**TOTAL WEIGHT**.....3.6kg  
**PACKED**.....50 x Ø16cm  
**PITCHING TIME**.....10 mins  
**CARTON QTY**.....4

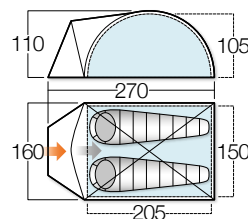

**300** TEMALPHA R19165 ●  
 TEMALPHA AA8165 ● CORE  
**TOTAL WEIGHT**.....4.2kg  
**PACKED**.....50 x Ø18cm  
**PITCHING TIME**.....10 mins  
**CARTON QTY**.....4

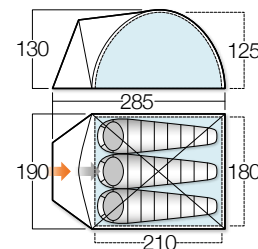

**400** TEMALPHA R19173 ●  
**TOTAL WEIGHT**.....5.1kg  
**PACKED**.....55 x Ø19cm  
**PITCHING TIME**.....10 mins  
**CARTON QTY**.....4

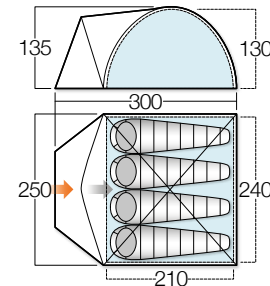

## OPTIONAL ADDITIONS



# SIGMA



The Sigma is an easy-to-pitch semi-geodesic dome tent. It not only offers a greater amount of space but has enhanced stability and superior fabrics that are waterproof and fire retardant for a dry, safe and comfortable camping experience. Flysheet first or all-in-one pitching ensures that your sleeping pod always stays dry if it is raining, making this feature-packed tent an ideal option for youth groups, and more adventurous campers.

## SPECIFICATION

**PITCHING** .....All-in-one  
**FLYSHEET** .....ProTex® 70D 3,000mm polyester  
**INNER** ..... Breathable polyester  
**GROUNDSHEET** ..... Polyethylene  
**POLES** .....PowerFlex® fibreglass

## FEATURES

- Semi-geodesic - self-supporting structure, providing excellent weight and stability balance
- Integrated eyelets allow optional king poles to prop open doors. Creates a canopy
- Factory taped seams - All flysheet and groundsheet seams are factory taped, making it watertight
- Linked-in groundsheet - Easy to clean groundsheet that can be attached or detached
- Lights out inner tent - Darker fabric reduces the amount of early morning light
- Part mesh inner door - Allows ventilation, whilst keeping bugs out
- Lantern hanging points - Conveniently positioned in the living and bedroom areas
- Inner pockets - Conveniently positioned pockets for organising essential items
- Diamond Clear windows - Maximise light and visibility.
- Fast pack tent bag - Oversized opening and compression straps to control pack size
- Reflective webbing - Picks up torchlight so the pegging points are easily spotted in low light
- High visibility guylines - Easy to see in low light conditions.
- Weather tested to the European standard EN5912 by certified test centre
- Fire retardant fabrics - Meets European EN5912 safety standard



## 300

TEMSIGMA R19165

**TOTAL WEIGHT** ..... 5.00kg  
**PACKED** ..... 60 x Ø18cm  
**PITCHING TIME** ..... 10 mins  
**CARTON QTY** ..... 2  
**STD ORDER QTY** ..... 2

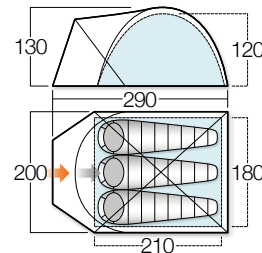

## 300+

TEMSIGMA R19210

**TOTAL WEIGHT** ..... 6.10kg  
**PACKED** ..... 61 x Ø20cm  
**PITCHING TIME** ..... 12 mins  
**CARTON QTY** ..... 2  
**STD ORDER QTY** ..... 2

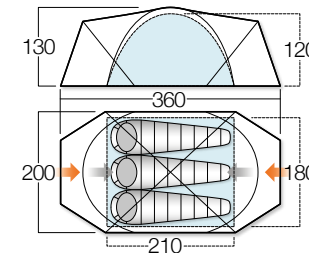

## OPTIONAL ADDITIONS



The popular Beta XL is a 3-pole tunnel tent that offers generous sleeping space combined with a large, functional porch area for storing your camping essentials. Recommended by The Scout Association, this feature-packed tent includes Vango's patented TBS®II (Tension Band System) to provide additional stability in poor conditions, and all-in-one pitching ensures that the sleeping pod always stays dry if it is raining. Ideal for slightly longer trips and will also appeal to campers seeking a more spacious and comfortable weekend tent.

## SPECIFICATION

**PITCHING** .....All-in-one  
**FLYSHEET** .....ProTex® 70D 3,000mm polyester  
**INNER** ..... Breathable polyester  
**GROUNDSHEET** ..... Polyethylene  
**POLES** .....PowerFlex® fibreglass

## FEATURES

- Tunnel tent - Style provides greatest space to weight ratio
- Patented Vango TBS®II Tension Band System ensures tent performs in adverse conditions
- Factory taped seams - all flysheet and groundsheet seams are factory taped, making it watertight
- Linked-in groundsheet - easy to clean groundsheet that can be attached or detached from the living area. Simply roll under the bedroom area when not required.
- Colour coded poles for intuitive pitching
- Lights out inner tent - darker fabric reduces the amount of early morning light
- Part mesh inner door - allows ventilation, whilst keeping bugs out
- Multiple flysheet doors - entry from either side giving protection from prevailing winds
- Lantern hanging points - Conveniently positioned in the living and bedroom areas
- Inner pockets - Conveniently positioned pockets for organising essential items
- Diamond Clear windows - Maximise light and visibility.
- Fast pack tent bag - Oversized opening and compression straps to control pack size
- Reflective webbing - Picks up torchlight so the pegging points are easily spotted in low light
- High visibility gylines - Easy to see in low light conditions
- Weather tested to the European standard EN5912 by certified test centre



SIZE	MODEL	CORE	TOTAL WEIGHT	PACKED	PITCHING TIME	CARTON QTY	STD ORDER QTY
350XL	TEMBETA AA8S24 TEMBETA R19S24	●	7kg	64 x Ø21cm	10 mins	2	2
450XL	TEMBETA AA8S7D TEMBETA R19S7D	●	6.10kg	64 x Ø24cm	12 mins	2	2
550XL	TEMBETA R19S7E	●	11.1kg	64 x Ø24cm	15 mins	2	2

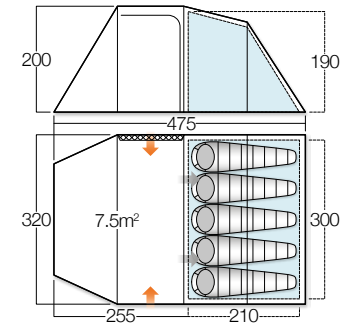
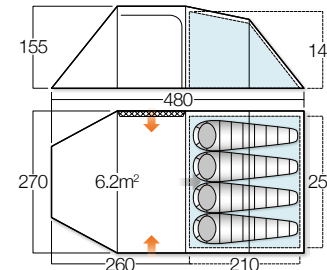
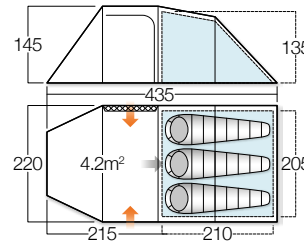

## OPTIONAL ADDITIONS





## ADVENTURE

### ADVENTURE ALLOY

New for 2018, our Adventure range introduces an upgraded collection of alloy poled adventure tents.

Quick pitch times and stronger components make the Adventure AL collection ideal for venturing into the wild and camping in bad weather or uneven ground. The upgraded zips and pegs add durability to the tents while the change to Powerlite Alloy poles reduce the overall weight by up to 15%.

These tents are perfect for adventurers looking for a semi technical tent with a small pack size and low weight that they can use to facilitate their adventure sports or outdoor activities. Whether it's camp site usage for groups or beach camping on a surf trip Adventure AL tents are made for short weekend trips on site or on location.

## ADVENTURE

### ALLOY



ZETA ALLOY 200



ZETA ALLOY 300+



DELTA ALLOY 200



DELTA ALLOY 300+



SIGMA ALLOY 300



BETA 350XL



BETA 550XL

# ZETA ALLOY NEW

The Zeta Alloy is an easy to pitch dome tent of amazing value. The lights out inner helps the tent maintain darkness long after sunrise, while the included roof pole offers additional headroom when entering and exiting the tent. Ventilation ports ensure condensation won't be an issue on your camping trip, while the porch area can be used to store all your camping equipment, leaving you with ample space inside the tent. With strong alloy poles, bigger, sturdier zips, and more durable pegs, it is seriously robust and resistant to wear and tear.

## SPECIFICATION

- PITCHING** ..... Inner first
- FLYSHEET** ..... ProTex® 70D 3,000mm polyester
- INNER** ..... Breathable polyester
- GROUNDSHEET** ..... Polyethylene
- POLES** ..... Vango PowerLite® 7001-T6 Alloy

## FEATURES

- Factory taped seams - All flysheet and groundsheet seams are factory taped, making it watertight
- Lights out inner tent - Darker fabric reduces the amount of early morning light
- Vango PowerLite® 7001-T6 alloy poles - Lightweight and durable tent poles
- Oversized zips - Bigger, stronger and more durable zips
- Part mesh inner door - Allows ventilation, whilst keeping bugs out
- Lantern hanging points - Conveniently positioned
- Inner pockets - Conveniently positioned pockets for organising essential items
- Fast pack tent bag - Oversized opening and compression straps to control pack size
- Stronger steel pegs - More durable and bigger pegs
- Reflective guylines - Easy to see in low light conditions.
- Weather tested to the European standard EN5912 by certified test centre



**300+** TENZETA C05210

- TOTAL WEIGHT** ..... 3.49kg
- PACKED** ..... 50 x Ø16cm
- PITCHING TIME** ..... 10 mins
- CARTON QTY** ..... 4
- STD ORDER QTY** ..... 4

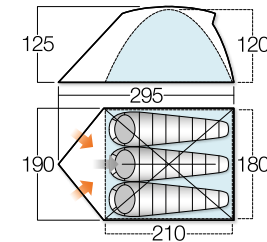

## OPTIONAL ADDITIONS



# DELTA ALLOY NEW

New for 2018, the Delta Alloy is a front-and-side-entry tunnel tent which comes with two canopy poles to create a sheltered porch area. This porch is ideal for cooking and enjoying the view, whilst the two-door entry system ensures easy access in and out the tent. All-in-one pitching means that the sleeping pod stays dry in rainy weather, while generous head room lets you to sit up in the tent without worrying about condensation. An ideal choice for first time adventurers, youth groups and festivals, the Delta Alloy comes with strong alloy poles, sturdier zips, and more durable pegs, making it much more robust and resistant to wear and tear.

## SPECIFICATION

**PITCHING** .....All-in-one  
**FLYSHEET** .....ProTex® 70D 3,000mm polyester  
**INNER** ..... Breathable polyester  
**GROUND SHEET** ..... Polyethylene  
**POLES** ..... Vango PowerLite® 7001-T6 Alloy

## FEATURES

- Factory taped seams - All flysheet and groundsheet seams are factory taped, making it watertight
- Vango PowerLite® 7001-T6 alloy poles - Lightweight and durable tent poles
- Lights out inner tent - Darker fabric reduces the amount of early morning light
- Part mesh inner door - Allows ventilation, whilst keeping bugs out
- Twin flysheet doors - Allows easier access for two or more occupants, and/or additional storage
- Lantern hanging points - Conveniently positioned in the living and bedroom areas
- Inner pockets - Conveniently positioned pockets for organising essential items
- Fast pack tent bag - Oversized opening and compression straps to control pack size
- Reflective guylines - Easy to see in low light conditions
- Canopy poles supplied – Providing additional shelter
- Stronger steel pegs – More durable and bigger pegs
- Oversized zips – Bigger, stronger and more durable
- Weather tested to the European standard EN5912 by certified test centre



## 200 TENDELTA05151

**TOTAL WEIGHT** ..... 4.07kg  
**PACKED** ..... 50 x Ø17cm  
**PITCHING TIME** ..... 10 mins  
**CARTON QTY** ..... 4  
**STD ORDER QTY** ..... 4

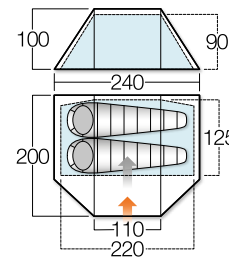

## 300 TENDELTA05165

**TOTAL WEIGHT** ..... 4.83kg  
**PACKED** ..... 55 x Ø19m  
**PITCHING TIME** ..... 10 mins  
**CARTON QTY** ..... 4  
**STD ORDER QTY** ..... 4

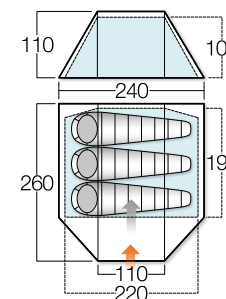

## OPTIONAL ADDITIONS





# BETA ALLOY NEW

The popular Beta Alloy is a 3-pole tunnel tent that offers generous sleeping space combined with a large, functional porch area for storing your camping essentials. The alloy variation of this tent has strong alloy poles, sturdier zips and more durable pegs, making it much more robust and resistant to wear and tear. This feature-packed tent also includes Vango's patented TBS®II (Tension Band System) to provide additional stability in poor conditions, and all-in-one pitching ensures that the sleeping pod always stays dry if it is raining. The Beta is ideal for slightly longer trips and appeals to campers seeking a more spacious and comfortable weekend tent.

## SPECIFICATION

**PITCHING** ..... All-in-one  
**FLYSHEET** ..... ProTex® 70D 3,000mm polyester  
**INNER** ..... Breathable polyester  
**GROUND SHEET** ..... Polyethylene  
**POLES** ..... Vango PowerLite® 7001-T6 Alloy

## FEATURES

- Tunnel tent - Style provides greatest space to weight ratio
- Patented Vango TBS®II Tension Band System ensures tent performs in adverse conditions
- Factory taped seams - All flysheet and groundsheet seams are factory taped, making it watertight
- Linked-in groundsheet - Easy to clean groundsheet that can be attached or detached
- Colour coded poles for intuitive pitching
- Lights out inner tent - Darker fabric reduces the amount of early morning light
- Oversized zips - Bigger, stronger and more durable zips
- Part mesh inner door - Allows ventilation, whilst keeping bugs out
- Multiple flysheet doors - Provides easy entry from either side giving protection from prevailing winds
- Lantern hanging points - Conveniently positioned in the living and bedroom areas
- Inner pockets - Conveniently positioned pockets for organising essential items
- Diamond Clear windows - Maximise light and visibility.
- Fast pack tent bag - Oversized opening and compression straps to control pack size
- Stronger steel pegs - More durable and bigger pegs
- Reflective webbing - Picks up torchlight so the pegging points are easily spotted in low light
- High visibility guylines - Easy to see in low light conditions



## 350XL TENBETAALC05S24

**TOTAL WEIGHT** ..... 6.14kg  
**PACKED** ..... 65 x Ø25cm  
**PITCHING TIME** ..... 15 mins  
**CARTON QTY** ..... 2  
**STD ORDER QTY** ..... 2

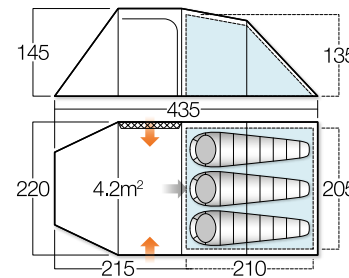

## 550XL TENBETAALC05S7E

**TOTAL WEIGHT** ..... 9.18kg  
**PACKED** ..... 65 x Ø29cm  
**PITCHING TIME** ..... 15 mins  
**CARTON QTY** ..... 2  
**STD ORDER QTY** ..... 2

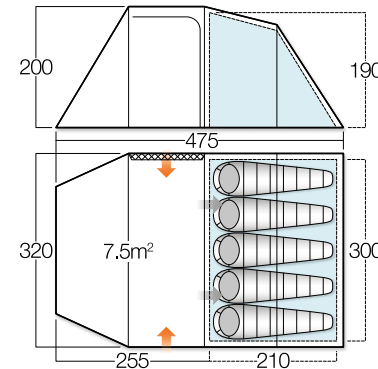

## OPTIONAL ADDITIONS





## FAMILY POLED TENTS

*The introduction of our innovative Vango AirBeam® range, whilst revolutionary, has not reduced the demand for high quality, thoughtfully designed, poled family tents. Our research over the past year with family campers has highlighted the requirement for a varied range of poled tents that meet consumers needs in terms of usable space, layout, quality and price.*

*All tents in the Exceed collection have been re-designed to include a new higher footer which adds an element of sophistication to the overall look of the range. This diverse collection of tents utilises our exclusive Protex® 70 denier polyester flysheet and comes in various sizes and layout's, so there truly is something to suit all.*

*Exceed Plus, our premium poled tent collection, now has the addition of our elegant tipi style tent Rosewood which utilises our premier TC polycotton flysheet. The Exceed Plus collection also includes our ever-popular Hayward which comes in our vibrant sky blue colourway and uses Protex 150D fabric. This collection truly adds luxury to any camping holiday.*

*Furthermore, for 2018 we have re-designed our tent bag by making it expandable with an oversized wide opening. This update will help take the stress out of packing away your tent after a great camping holiday.*

### EXPERIENCE

Entry level family poled tents

### EXCEED

The finest selection of family tents

### EXCEED PLUS

The ultimate luxury

# FAMILY POLED TENT ADDITIONS

	TENT	STATUS	AWNING	AWNING ZIP ATTACHMENT	FITTED CARPET	UNIVERSAL CARPET	FOOTPRINT	PORCH DOOR
EXPERIENCE	Hogan Hub	Updated	-	-	-	240 x 300cm	-	-
	Ascott 500	New	-	-	-	170 x 310cm	Ascott 500	-
	Winslow 400	New	-	-	-	130 x 240cm	Winslow 400	-
	Winslow 500	New	-	-	-	140 x 320 cm	Winslow 500	-
	Winslow 600	New	-	-	-	140 x 320 cm	Winslow 600	-
	Ashton 500	New	-	-	-	140 x 320 cm	Ashton 500 & Extension Groundsheet	-
	Longleat 800XL	New	Longleat Side Awning	No	-	230 x 210cm	Longleat 800XL	-
	Woburn 400	Updated	Family Shelter	-	-	230 x 210cm	Woburn 400	-
	Woburn 500	Updated	Family Shelter	-	-	240 x 300cm	Woburn/Calder 500	-
	Avington 500	Updated	-	-	-	140 x 320 cm	Avington 500 & Extension Groundsheet	✓
	Avington 500XL	Updated	Avington/Langley XL Side Awning	No	-	240 x 300cm	Avington 500XL & Extension Groundsheet	✓
Avington 600XL	Updated	Avington/Langley XL Side Awning	No	-	260 x 360cm	Avington 600XL & Extension Groundsheet	✓	
EXCEED	Calder 500	Updated	-	-	-	240 x 300cm	Woburn/Calder 500	-
	Calder 600	Updated	-	-	-	240 x 300cm	Calder 600	-
	Stanford 800XL	Updated	Stanford Side Awning	No	-	240 x 300cm	Stanford 800XL	-
	Mama 600XL	Updated	-	-	-	260 x 360cm	Mama 600XL & Awning Groundsheet	-
	Hudson 500	New	Family Shelter	No	-	170 x 310cm	Hudson/Amalfi 500	-
	Hudson 600	New	Family Shelter	No	-	170 x 310cm	Hudson/Amalfi 600	-
	Langley 400XL	Updated	Avington/Langley XL Side Awning	No	-	240 x 300cm	Langley 400XL & Extension Groundsheet	✓
	Langley 600XL	Updated	Avington/Langley XL Side Awning	No	-	260 x 360cm	Langley 600XL & Extension Groundsheet	✓
	Orava 500XL	Updated	Orava Side Awning	No	-	260 x 360cm	Orava/Taiga 500XL & Awning Groundsheet	-
	Orava 600XL	Updated	Orava Side Awning	No	-	270 x 430cm	Orava/Taiga 600XL & Awning Groundsheet	-
	Casa	New	-	-	-	260 x 360cm	Casa & Extension Groundsheet	-
EXCEED EXCEED PLUS TC PLUS	Hayward 600XL	Updated	-	-	✓	260 x 360cm	Hayward 600XL & Extension Groundsheet	✓
	Rosewood	New	-	-	✓	240 x 300cm	Rosewood	-



## FAMILY POLED

### EXPERIENCE

The all new Vango Experience collection has been designed to introduce families with a love for the outdoors to the adventures of camping.

Featuring our Vango Protex® 70 denier polyester flysheet, 3000mm HH waterproofness, this collection comes in our bright treetops green or sophisticated cloud grey colourways. Further features include our patented Vango TBS®II Tension Band System ensuring your tent performs in adverse conditions, light's out inners for a great night sleep, and our new flexible door step allowing easy access into your tent.

This is the perfect range for first time campers due to its superior quality and value for money, from Vango, with our rich heritage and trust in the outdoors. This collection features tents which can comfortably sleep from 4 to 8 people and includes an event shelter. There is truly something to suit every new camper or adventure enthusiast. This range is a great way to experience Vango and the great outdoors, together.



**FAMILY POLED**

**EXPERIENCE**



**HOGAN HUB**



**ASCOTT 500**



**WINSLOW 400**



**WINSLOW 500**



**WINSLOW 600**



**ASHTON 500**



**LONGLEAT 800XL**

# HOGAN HUB UPDATED

The Hogan Hub has generous stand-up height and a wide construction, making this a really bright and airy event shelter. We have included all four doors and a groundsheet so you are ready for any weather condition. Each door has a mesh panel to keep out the biting bugs and four zips, which means you have complete flexibility to leave them fully open, partly open or fully closed. The choice is yours.

## SPECIFICATION

**PITCHING**.....All-in-one  
**BODY**.....ProTex® 70D 3000mm polyester  
**POLES**.....PowerFlex® fibreglass

## FEATURES

- **Lantern Hanging Points** - conveniently positioned to attach your light(s).
- **High visibility guylines** - easy to see in low light conditions.
- **Waterproof PE groundsheet** - robust and hardwearing fabric.
- **Taped flysheet and groundsheet seams** - provides watertight seal.
- **Weather tested** to the European standard EN5912 by certified test centre.
- **Fire retardant fabrics** - meets European EN5912 safety standard.



CLOUD  
TENHOGAN S0YZ08

**TOTAL WEIGHT**..... 13kg  
**PACKED** ..... 68 x 24 x 20cm  
**PITCHING TIME**..... 15mins  
**CARTON QTY**..... 1  
**STD ORDER QTY**..... 1

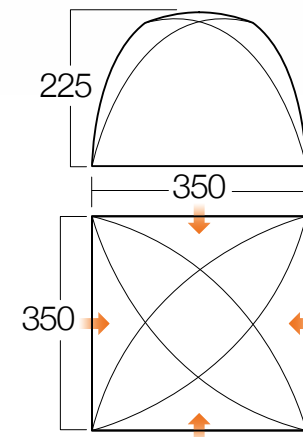

## OPTIONAL ADDITIONS



**UNIVERSAL CARPET**  
240 x 300 CPNUNIVERW11G28



**FAMILY WINDBREAK**  
CLOUD GREY TENWINDBRC3YZ05

# ASCOTT NEW

The quick pitch three pole tunnel design of Ascott makes it perfect for weekend camping adventures with family or friends. The Vango build quality and features are evident, including our fully sewn-in groundsheet, fully seam taped waterproof flysheet and main door entrance cover preventing rain from falling into the spacious living area. Ascott is a great value option for those new to camping who want a tent they can trust and rely on.

## SPECIFICATION

- PITCHING** ..... All-in-one  
**FLYSHEET** ..... Protex® 70D polyester flysheet, 3000mm  
**INNER** ..... Breathable polyester 180T  
**GROUNDSHEET** ..... Polyethylene  
**POLES** ..... PowerFlex fibreglass®

## FEATURES

- **Fully Sewn-in Groundsheet** - adds to the comfort of your tent by providing a bug and draught free environment.
- **Flexible door step** - an adaptable door step which can easily be dropped to ground level allowing you to effortlessly enter your tent without needing to step over the entrance.
- **Covered entrance** - sheltered entrance to your tent prevents rain from dripping in to the living area.
- **Mesh flysheet door** - a full mesh door provides ventilation and keeps bugs out.
- **Diamond Clear windows** - maximise light and visibility.
- **Bedroom pockets** - conveniently positioned pockets for storing your essentials.
- **Lights out inner tent** - darker fabric reduces the amount of early morning light.
- **TBS®II - Tension Band System** - ensures tent performs in adverse conditions.
- **Cable entry point with tidies** - zipped entry point for power cable, with touch fastener tidies.
- **Lantern Hanging Points** - conveniently positioned to attach your light(s).
- **High visibility guylines** - easy to see in low light conditions.
- **Weather tested** to the European standard EN5912 by certified test centre.
- **Fire retardant fabrics** - Meets European EN5912 safety standard.



**500** TENASCOTT15177 ● TREETOPS CORE  
 TENASCOTT3Y177 ● CLOUD GREY

- TOTAL WEIGHT** ..... 11.94kg  
**PACKED** ..... 73 x 28 x 28cm  
**PITCHING TIME** ..... 17 mins  
**CARTON QTY** ..... 1  
**STD ORDER QTY** ..... 1

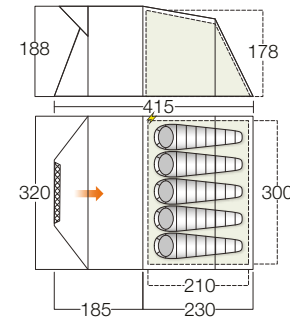

## OPTIONAL ADDITIONS



**FOOTPRINT**  
 FPNASCOTTB05177



**UNIVERSAL CARPET**  
 170 X 310 CPNUNIVER W11 G35



**FAMILY WINDBREAK**  
 CLOUD GREY TENWINDBRC3YZ05  
 HERBAL TENWINDBRH09Z05

# WINSLOW NEW

The Winslow is the perfect tunnel tent for small families, or couples, who may be new to camping, or seeking a fantastic value tent for weekend escapes. A spacious living area with large front entry provides flexibility whilst allowing easy movement around the tent. Large windows flood the living space with light, whilst curtains afford privacy, and our lights out inner bedrooms allow for a sound nights sleep.

## SPECIFICATION

**PITCHING** ..... All-in-one  
**FLYSHEET** ..... Vango Protex® 70D polyester, 3000mm  
**INNER** ..... Breathable polyester 180T  
**GROUND SHEET** ..... Polyethylene  
**POLES** ..... Vango PowerFlex® fibreglass

## FEATURES

- **Fully Sewn-in Groundsheet** - adds to the comfort of your tent by making a bug and draught free environment.
- **Flexible door step** - an adaptable door step which can easily be dropped to ground level allowing you to effortlessly enter your tent without needing to step over the entrance.
- **Mesh flysheet door** - one (or more) entrance has a full mesh door. Provides ventilation and keeps bugs out.
- **Diamond Clear windows** - maximise light and visibility.
- **Bedroom pockets** - conveniently positioned pockets for storing your essentials.
- **Lights out inner tent** - darker fabric reduces the amount of early morning light.
- **Toggled inner divider** - flexible options for sleeping or provides increased living space.
- **Patented Vango TBS®II Tension Band System ensures tent performs in adverse conditions.**
- **Cable entry point with tidies** - zipped entry point for power cable, with touch fastener tidies.
- **King Pole Doors** - Integrated eyelets allow optional king poles to prop open doors. Creates a canopy
- **Lantern Hanging Points** - conveniently positioned to attach your light(s).
- **High visibility guylines** - easy to see in low light conditions.
- **Weather tested** to the European standard EN5912 by certified test centre.
- **Fire retardant fabrics** - meets European EN5912 safety standard.



**400** TENWINSLOC3Y173

**TOTAL WEIGHT** ..... 11.56kg  
**PACKED** ..... 73 x 28 x 28cm  
**PITCHING TIME** ..... 15 mins  
**CARTON QTY** ..... 1  
**STD ORDER QTY** ..... 1

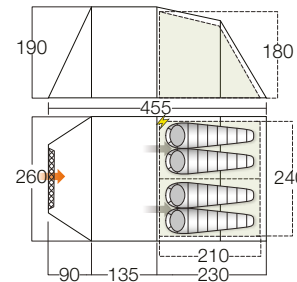

**500** TENWINSLOC3Y177 CORE

**TOTAL WEIGHT** ..... 13.04kg  
**PACKED** ..... 73 x 30 x 30cm  
**PITCHING TIME** ..... 15 mins  
**CARTON QTY** ..... 1  
**STD ORDER QTY** ..... 1

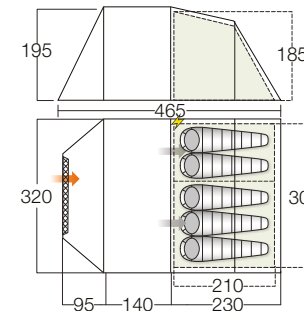

**600** TENWINSLOC3Y181

**TOTAL WEIGHT** ..... 14.32kg  
**PACKED** ..... 73 x 32 x 32cm  
**PITCHING TIME** ..... 15 mins  
**CARTON QTY** ..... 1  
**STD ORDER QTY** ..... 1

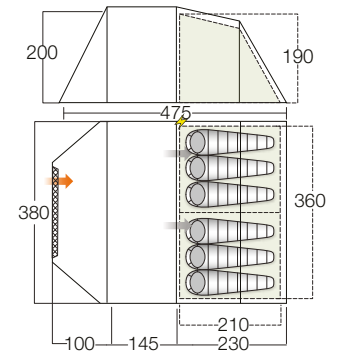

## OPTIONAL ADDITIONS



### FOOTPRINT

400 FPNWINSLOB05173  
 500 FPNWINSLOB05177  
 600 FPNWINSLOB05181



### UNIVERSAL CARPET

400 / 130 X 240 CPNUNIVERW11G24  
 500 / 140 X 320 CPNUNIVERW11G34  
 600 / 140 X 320 CPNUNIVERW11G34



### FAMILY WINDBREAK CLOUD GREY TENWINDBRC3YZ05



### ADJUSTABLE STEEL KING POLES ACXKINGPO3F6Z01



# ASHTON NEW HERO

The Ashton 500 is a 4 pole tunnel tent with a pre-attached front extension creating the perfect balance between indoor and outdoor sheltered living space. This easy to pitch tent is perfect for families, couples or groups of friends wanting to get away from the hustle and bustle of everyday life. The large main door and windows ensure a light, airy feel for enjoying the great outdoors.

## SPECIFICATION

- PITCHING** ..... All-in-one
- FLYSHEET** ..... ProTex® 70D 3,000mm polyester
- INNER** ..... Breathable polyester 180T
- GROUNDSHEET** ..... Polyethylene
- POLES** ..... PowerFlex® fibreglass

## FEATURES

- **Fully Sewn-in Groundsheet** - adds to the comfort of your tent by providing a bug and draught free environment.
- **Pre-attached extension** - front canopy built into the design of the tent offering generous extra living space.
- **Flexible door step** - an adaptable door step which can easily be dropped to ground level allowing you to effortlessly enter your tent without needing to step over the entrance.
- **Covered entrance** - a sheltered entrance to your tent prevents rain from dripping in to the living area.
- **Mesh flysheet door** - a full mesh door provides ventilation and keeps bugs out.
- **Diamond Clear windows** - maximise light and visibility.
- **Bedroom pockets** - conveniently positioned pockets for storing your essentials.
- **Lights out inner tent** - darker fabric reduces the amount of early morning light.
- **Togged inner divider** - flexible options for sleeping or provides increased living space.
- **Patented Vango TBS®II Tension Band System ensures tent performs in adverse conditions.**
- **Cable entry point with tidies** - zipped entry point for power cable, with touch fastener tidies.
- **Lantern Hanging Points** - conveniently positioned to attach your light(s).
- **High visibility guylines** - easy to see in low light conditions.
- **Weather tested** to the European standard EN5912 by certified test centre.
- **Fire retardant fabrics** - meets European EN5912 safety standard.



**500** TENSHTONC3Y177 CLOUD GREY CORE  
 TENSHTONT15177 TREETOPS

**TOTAL WEIGHT** ..... 14.7kg  
**PACKED** ..... 73 x 31 x 31cm  
**PITCHING TIME** ..... 18 mins  
**CARTON QTY** ..... 1  
**STD ORDER QTY** ..... 1

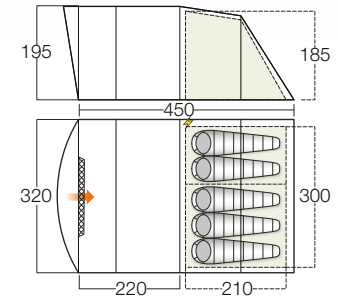

## OPTIONAL ADDITIONS



**FOOTPRINT & EXTENSION GROUND SHEET**  
 500 FPNASHTONB05177



**UNIVERSAL CARPET**  
 140 X 320 CPNUNIVERW1 1G34



**FAMILY WINDBREAK**  
 CLOUD GREY TENWINDBRC3YZ05  
 HERBAL TENWINDBRH09Z05

# LONGLEAT NEW

Longleat is a vis-à-vis tunnel tent offering generous, balanced living and sleeping space. The fully sewn in groundsheet ensures that draughts and bugs are minimised, while increasing the ease of pitching. Large windows with curtains give you a great view, yet privacy when required. To add to your internal space, why not fit the optional side awning to create a true home from home?

## SPECIFICATION

**PITCHING** ..... All-in-one  
**FLYSHEET** ..... Vango Protex® 70D polyester flysheet, 3000mm  
**INNER** ..... Breathable polyester 180T  
**GROUND SHEET** ..... Polyethylene  
**POLES** ..... PowerFlex® fibreglass

## FEATURES

- **Pre-angled poles** - greater internal space and effective bracing against side winds.
- **All flysheet seams are factory taped** - provides watertight seal.
- **Fully Sewn-in Groundsheet** - providing a bug and draught free environment.
- **Waterproof PE groundsheet** - hardwearing fabric to stand up to the rigours of the most active campers.
- **PE bathtub groundsheet in bedrooms** - provides a robust, high-sided, waterproof base.
- **Flexible door step** - an adaptable door step which can easily be dropped to ground level allowing you to effortlessly enter your tent without needing to step over the entrance.
- **Mesh flysheet door** - a full mesh door provides ventilation and keeps bugs out.
- **Diamond Clear windows** - maximise light and visibility.
- **Bedroom pockets** - conveniently positioned pockets for storing your essentials.
- **Lights out inner tent** - darker fabric reduces the amount of early morning light.
- **Spacious ISO standard sized bedrooms.**
- **King Pole Doors** - Integrated eyelets allow optional king poles to prop open doors. Creates a canopy
- **Toggled inner divider** - flexible options for sleeping or providing increased living space.
- **Double living area** - an extra large living area giving more space for all your camping essentials.
- **Cable entry point with tidies** - zipped entry point for power cable, with touch fastener tidies.
- **Lantern Hanging Points** - conveniently positioned to attach your light(s).



**800XL** TENLONGLEC3Y184

**TOTAL WEIGHT** ..... 19.72kg  
**PACKED** ..... 78 x 32 x 32cm  
**PITCHING TIME** ..... 22 mins  
**CARTON QTY** ..... 1  
**STD ORDER QTY** ..... 1

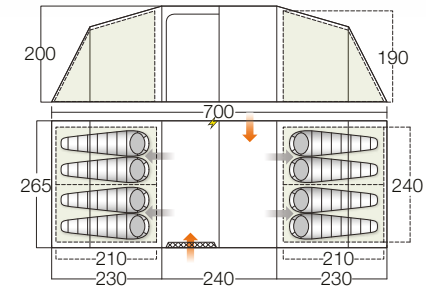

## OPTIONAL ADDITIONS



**FOOTPRINT**  
800XL FPNLONGLEB05184



**UNIVERSAL CARPET**  
230 X 210 CPNUNIVERW11G26



**AWNING**  
CLOUD TANLONGLEC3YTHG



**ADJUSTABLE STEEL KING POLES**  
ACXKINGPO3F6Z01



## FAMILY POLED

### EXCEED

Our ever popular Exceed poled tent collection offers something for every family camper. This range features tents which can comfortably sleep from 4 to 8 people and has been updated for 2018 with a sophisticated new design with the addition of a higher footer.

Combining our exclusive ProTex<sup>®</sup> 70 denier polyester flysheet with our lightweight but strong Powerflex<sup>®</sup> fibreglass poles makes these tents highly waterproof, robust and ideal for weekends away or longer family trips.

The Exceed collection is packed full of great features such as our unique patented TBS II<sup>®</sup> technology ensuring your tent performs in adverse conditions, AirZone<sup>®</sup> ventilation systems which helps reduce condensation and our new expandable tent bag making packing away your tent stress free after a great holiday.



**FAMILY POLED**

**EXCEED**



**WOBURN 400**



**WOBURN 500**



**AVINGTON 500**



**AVINGTON 500XL**



**AVINGTON 600XL**



**CALDER 500**



**CALDER 600**



**STANDFORD 800XL**



**MARNA 600XL**



**HUDSON 500**



**HUDSON 600**



**LANGLEY 400XL**



**LANGLEY 600XL**



**ORAVA 500XL**



**ORAVA 600XL**



**CASA**

# WOBURN UPDATED

The Woburn is a classic 3 fibreglass pole weekend tunnel tent which boasts full stand up height throughout and large front windows that allow light to flood into the tent. This family tent is the perfect balance of living space and has a large bedroom area with central divider. Ideal for couples or small families that want an affordable option with absolute functionality for short countryside breaks.

## SPECIFICATION

- PITCHING** ..... All in one  
**FLYSHEET** ..... Vango ProTex® 70D polyester 4,000mm  
**INNER** ..... Breathable polyester 190T  
**GROUNDSHEET** ..... Polyethylene  
**POLES** ..... PowerFlex® fibreglass

## FEATURES

- **NEW Expandable tent bag** - oversized wide opening makes it simpler to pack away your tent.
- **Linked-in groundsheet** - easily attached or detached; simply roll under the bedroom area.
- **TBS®II - Tension Band System** - ensures tent performs in adverse conditions.
- **Waterproof PE groundsheet** - hardwearing fabric to stand up to the rigours of the most active campers.
- **Mesh flysheet door** - one (or more) entrance has a full mesh door. Provides ventilation and keeps bugs out.
- **Lantern Hanging Points** - conveniently positioned to attach your light(s).
- **Lights out inner tent** - darker fabric reduces the amount of early morning light.
- **Toggle inner divider** - flexible options for sleeping or providing increased living space.
- **Bedroom pockets** - conveniently positioned pockets for storing your essentials.
- **Part mesh inner door** - allows ventilation, whilst keeping bugs out.
- **King Pole Doors** - Integrated eyelets allow optional king poles to prop open doors. Creates a canopy
- **Diamond Clear windows** - maximise light and visibility.
- **Toggle privacy curtains** - provides privacy when required, can be rolled away when not in use.
- **Vango AirZone** - reduce condensation with high and low level ventilation panels.
- **High visibility gylines** - easy to see in low light conditions.
- **Weather tested** to the European standard EN5912 by certified test centre.
- **Fire retardant fabrics** - meets European EN5912 safety standard.



HERBAL  
400 shown

## 400 TENWOBURNH09173

- TOTAL WEIGHT** ..... 12.00kg  
**PACKED** ..... 64 x 27 x 27cm  
**PITCHING TIME** ..... 15 mins  
**CARTON QTY** ..... 1  
**STD ORDER QTY** ..... 1

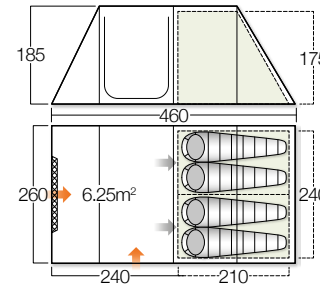

## 500 TENWOBURNH09177 CORE

- TOTAL WEIGHT** ..... 13.20kg  
**PACKED** ..... 64 x 31 x 29cm  
**PITCHING TIME** ..... 15 mins  
**CARTON QTY** ..... 1  
**STD ORDER QTY** ..... 1

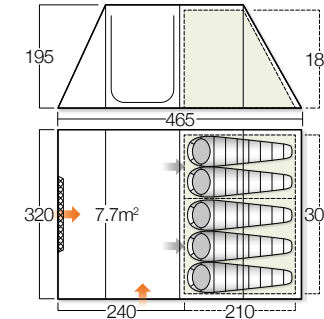

## OPTIONAL ADDITIONS



**FOOTPRINT**  
 400 / FPNWOBURNB05173  
 500 / FPNWOBURNB05177



**UNIVERSAL CARPET**  
 400 / 230 X 210 CPNUNIVERW11G26  
 500 / 240 X 300 CPNUNIVERW11G26



**FAMILY SHELTER**  
 TPNFAMILYH09Z05



**ADJUSTABLE STEEL KING POLES**  
 ACXKINGP03F6Z01

# AVINGTON UPDATED

The Avington is a stylish, compact and functional tunnel tent, which is a perfect size for family getaways. The sewn-in groundsheet adds to the comfort of your tent, providing a bug and draught free environment. Enjoy a great nights sleep with 'lights-out inners' that have handy bedroom pockets to keep your essentials close to hand. The pre-attached extension creates a shelter for food preparation or simply sitting out enjoying the view.

## SPECIFICATION

**PITCHING** ..... All-in-one  
**FLYSHEET** ..... Vango ProTex® 70D polyester 4,000mm  
**INNER** ..... Breathable polyester 190T  
**GROUNDSHEET** ..... Polyethylene  
**POLES** ..... PowerFlex® Fibreglass

## FEATURES

- **NEW Expandable tent bag** - oversized wide opening makes it simpler to pack away your tent.
- **Fully Sewn-in Groundsheet** - provides a bug and draught free environment.
- **TBS®II - Tension Band System** - ensures tent performs in adverse conditions.
- **Pre-angled poles** - greater internal space, provides effective bracing against side winds (XL only).
- **Pre-attached front extension** - offering generous extra living space.
- **Double entry** - from front or side into living area (front entrance has a full mesh door).
- **Large double-section living area (on XL)** - additional space, perfect for longer trips.
- **Diamond-Clear PVC windows with privacy curtains** - maximises light and visibility.
- **Vango AirZone high and low ventilation** - provides maximum airflow.
- **Lights-out inner** - helps reduce the amount of early morning light.
- **Toggled inner divider** - flexible options for sleeping or increased living space.
- **Part mesh inner doors** - allows ventilation, whilst keeping bugs out.
- **King Pole Doors** - Integrated eyelets allow optional king poles to prop open doors. Creates a canopy
- **Multiple lantern hanging points** - conveniently positioned at all living area poles.
- **Bedroom storage pockets** - conveniently positioned for organising essential items.
- **High visibility gylines** - easy to see in low light conditions.
- **Weather tested** to the European standard EN5912 by certified test centre.
- **Fire retardant fabrics** - meets European EN5912 safety standard.



## 500 TENAVINGTH09177 CORE

**TOTAL WEIGHT** ..... 13.20kg  
**PACKED** ..... 70 x 27 x 27cm  
**PITCHING TIME** ..... 18 mins  
**CARTON QTY** ..... 1  
**STD ORDER QTY** ..... 1

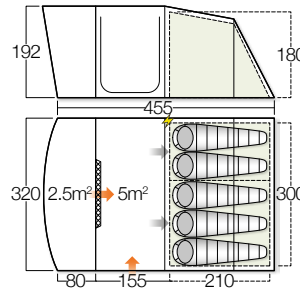

## 500XL TENAVINGTH09TAP CORE

**TOTAL WEIGHT** ..... 19.90kg  
**PACKED** ..... 70 x 31 x 31cm  
**PITCHING TIME** ..... 20 mins  
**CARTON QTY** ..... 1  
**STD ORDER QTY** ..... 1

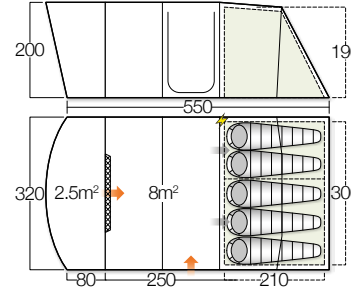

## 600XL TENAVINGTH09TAQ CORE

**TOTAL WEIGHT** ..... 21.90kg  
**PACKED** ..... 70 x 31 x 32cm  
**PITCHING TIME** ..... 20 mins  
**CARTON QTY** ..... 1  
**STD ORDER QTY** ..... 1

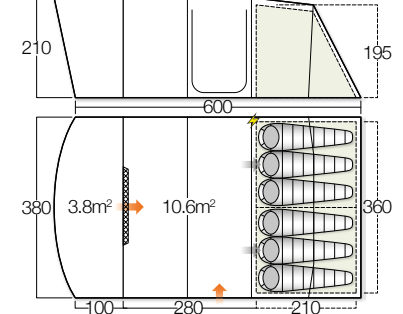

## OPTIONAL ADDITIONS



### FOOTPRINT & EXTENSION G/SHEET

500 FPNAVINGTB05177  
 500XL FPNAVINGTB05TAP  
 600XL FPNAVINGTB05TAQ



### UNIVERSAL CARPET

500 / 140 x 320 CPNUNIVERW11G34  
 500XL / 240 x 300 CPNUNIVERW11G28  
 600XL / 260 x 360 CPNUNIVERW11G29



### AVINGTON / LANGLEY XL AWNING

TANAVILANH09THK



### PORCH DOOR

500 PDNAVINGTH09177  
 500XL PDNAVINGTH09TAP  
 600XL PDNAVINGTH09TAQ



### ADJUSTABLE KING POLES

ACXKINGPO3F6Z01

# CALDER UPDATED

The Calder 600 is ideal for family campers, who want a versatile tent for quick getaways or longer camping breaks. The pre-attached sun canopy is great for preparing your tasty meals or even just as an outdoor sanctuary to relax under at the end of the day. Enjoy a great night's sleep in the lights-out inner's and keep all of your essentials close to hand with the handy bedroom pockets!

## SPECIFICATION

- PITCHING**.....All-in-one  
**FLYSHEET**.....Vango ProTex® 70D polyester 4,000mm  
**INNER**.....Breathable polyester  
**GROUND SHEET**.....Polyethylene  
**POLES**.....PowerFlex® Fibreglass

## FEATURES

- **NEW Expandable tent bag** - oversized wide opening makes it simpler to pack away your tent.
- All flysheet seams are **factory taped** - provides watertight seal.
- **Fully Sewn-in Groundsheet** - providing a bug and draught free environment.
- **TBS®II - Tension Band System** - ensures tent performs in adverse conditions.
- **Waterproof PE groundsheet** - hardwearing fabric to stand up to the rigours of the most active campers.
- **Pre-attached sun canopy** - relax outside your tent and shelter from sun or rain.
- **Covered entrance** - prevents rain from dripping in to the living area.
- **Mesh flysheet door** - one (or more) entrance has a full mesh door. Provides ventilation and keeps bugs out.
- **Diamond Clear windows** - maximise light and visibility.
- **Bedroom pockets** - conveniently positioned pockets for storing your essentials.
- **Lights out inner tent** - darker fabric reduces the amount of early morning light.
- **Toggled inner divider** - flexible options for sleeping or providing increased living space.
- **King Pole Doors** - Integrated eyelets allow optional king poles to prop open doors. Creates a canopy
- **Cable entry point with tidies** - zipped entry point for power cable, with touch fastener tidies.
- **Lantern Hanging Points** - conveniently positioned to attach your light(s).
- **High visibility guylines** - easy to see in low light conditions.
- **Weather tested** to the European standard EN5912 by certified test centre.
- **Fire retardant fabrics** - meets European EN5912 safety standard.

## OPTIONAL ADDITIONS



**FOOTPRINT**

500 FPNWOBURNB05177  
 600 FPNCALDERB05181



**UNIVERSAL CARPET**

500 / 240 X 300 CPNUNIVERW11G28  
 600 / 240 X 300 CPNUNIVERW11G28



**FAMILY WINDBREAK**

HERBALTENWINDBRH09Z05



**ADJUSTABLE STEEL KING POLES**

ACXKINGPO3F6Z01



HERBAL  
500 shown

## 500 TENCALDERH09177

- TOTAL WEIGHT**..... 16.10kg  
**PACKED**..... 70 x 31 x 30cm  
**PITCHING TIME**..... 18 mins  
**CARTON QTY**..... 1  
**STD ORDER QTY**..... 1

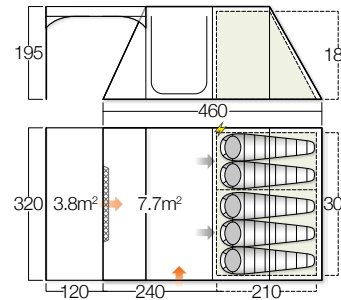

## 600 TENCALDERH09181



- TOTAL WEIGHT**..... 18.90kg  
**PACKED**..... 68 x 32 x 30cm  
**PITCHING TIME**..... 18 mins  
**CARTON QTY**..... 1  
**STD ORDER QTY**..... 1

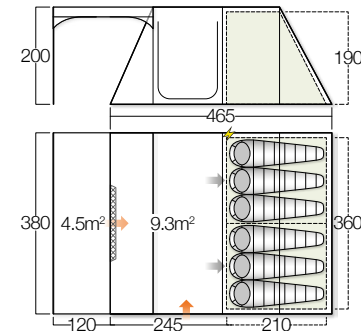

# STANFORD UPDATED

Featuring a vis-à-vis separate bedroom pod design, the Stanford 800XL is perfect for families who desire their own space and privacy. The pre-angled poles help achieve greater internal space as well as creating an effective bracing system against strong side winds, making sure you feel completely secure in your outdoor home. An over door canopy keeps the living area dry on wet days and large windows, with curtains for privacy, give you a great view of your surroundings.

## SPECIFICATION

**PITCHING** .....All-in-one  
**FLYSHEET** ..... Vango ProTex® 70D polyester 4,000mm  
**INNER** ..... Breathable polyester 190T  
**GROUND SHEET** ..... Polyethylene  
**POLES** ..... PowerFlex® fibreglass

## FEATURES

- **NEW Expandable tent bag** - oversized wide opening makes it simpler to pack away your tent.
- **Pre-angled poles** - greater internal space and effective bracing against side winds.
- **Fully Sewn-in Groundsheet** - providing a bug and draught free environment.
- **TBS®II - Tension Band System** - ensures tent performs in adverse conditions.
- **Generous king-sized bedrooms** - big enough to fit a double sized airbed or double sleep mat.
- **Waterproof PE groundsheet** - hardwearing fabric to stand up to the rigours of the most active campers.
- **Mesh flysheet door** - one (or more) entrance has a full mesh door. Provides ventilation and keeps bugs out.
- **Covered entrance** - prevents rain from dripping in to the living area.
- **Cable entry point with tidies** - zipped entry point for power cable, with touch fastener tidies.
- **Double living area** - an extra large living area giving more space for all your camping essentials.
- **King Pole Doors** - Integrated eyelets allow optional king poles to prop open doors. Creates a canopy
- **Lantern Hanging Points** - conveniently positioned to attach your light(s).
- **Lights out inner tent** - darker fabric reduces the amount of early morning light.
- **Toggled inner divider** - flexible options for sleeping or providing increased living space.
- **High visibility guylines** - easy to see in low light conditions.
- **Weather tested** to the European standard EN5912 by certified test centre.
- **Fire retardant fabrics** - meets European EN5912 safety standard.



HERBAL

## 800XL TENSTANFOH09TAS

**TOTAL WEIGHT** .....22.70kg  
**PACKED** ..... 70 x 36 x 29cm  
**PITCHING TIME** ..... 22 mins  
**CARTON QTY** ..... 1  
**STD ORDER QTY** ..... 1

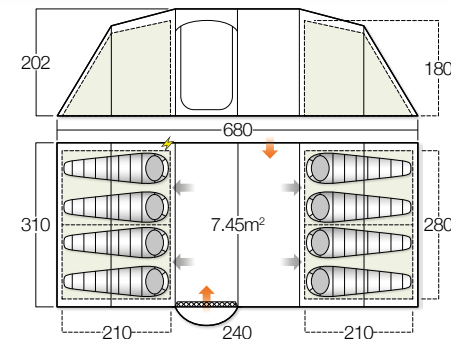

## OPTIONAL ADDITIONS



**FOOTPRINT**  
800XL FPNSTANFOB05TAS



**UNIVERSAL CARPET**  
240 X 300 CPNUNIVERW11G28



**STANFORD SIDE AWNING**  
HERBAL TANSTANFOH09THM



**ADJUSTABLE STEEL KING POLES**  
ACXKINGPO3F6Z01



# MARNA UPDATED

*This huge 6-person tent is a must-have for all of your upcoming camping trips with the family! Our oversized vents allow for greater ventilation and significantly reduce the chance of condensation building up. The huge pre-attached awning and double sectioned living area allows meal preparation to be separated from your luxurious home from home living space. Featuring pre-angled Fibreglass poles and luxurious lights-out inners with bedroom pockets, you will definitely be the envy of the campsite with the Marna 600XL.*

## SPECIFICATION

- PITCHING** .....All-in-one  
**FLYSHEET** ..... Vango ProTex® 70D polyester 4,000mm  
**INNER** ..... Breathable polyester 190T  
**GROUND SHEET** ..... Polyethylene  
**POLES** ..... PowerFlex® fibreglass

## FEATURES

- **NEW Expandable tent bag** - oversized wide opening makes it simpler to pack away your tent.
- **Pre-angled poles** - greater internal space and effective bracing against side winds.
- **TBS®II - Tension Band System** - ensures tent performs in adverse conditions.
- **Fully Sewn-in Groundsheet** - providing a bug and draught free environment.
- **Waterproof PE groundsheet** - hardwearing fabric to stand up to the rigours of the most active campers.
- **Mesh flysheet door** - one (or more) entrance has a full mesh door. Provides ventilation and keeps bugs out.
- **Covered entrance** - prevents rain from dripping in to the living area.
- **Double zip door** - increase ventilation by opening the top of the door.
- **Cable entry point with tidies** - zipped entry point for power cable, with touch fastener tidies.
- **Double living area** - an extra large living area giving more space for all your camping essentials.
- **Lantern Hanging Points** - conveniently positioned to attach your light(s).
- **Lights out inner tent** - darker fabric reduces the amount of early morning light.
- **Toggle inner divider** - flexible options for sleeping or providing increased living space.
- **High visibility gylines** - easy to see in low light conditions.
- **Weather tested** to the European standard EN5912 by certified test centre.
- **Fire retardant fabrics** - meets European EN5912 safety standard.



HERBAL

## 600XL TENMARNA H09TAQ

- TOTAL WEIGHT** ..... 24.80kg  
**PACKED** ..... 70 x 40 x 36cm  
**PITCHING TIME** ..... 25 mins  
**CARTON QTY** ..... 1  
**STD ORDER QTY** ..... 1

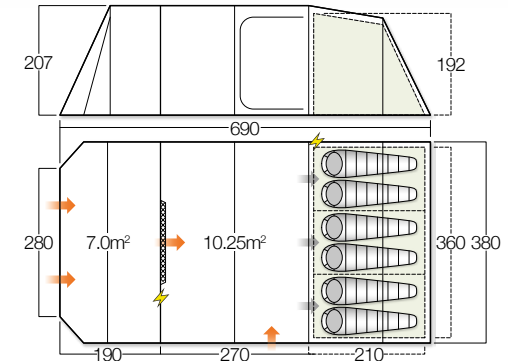

## OPTIONAL ADDITIONS



**FOOTPRINT & AWNING G/SHEET**  
600XL FPNMARNA B05TAQ



**UNIVERSAL CARPET**  
260 X 360 CPNUNIVERW11G29



**FAMILY WINDBREAK**  
HERBALTENWINDBRH09Z05

# HUDSON NEW HERO

The Hudson is a versatile family tent which is quick to pitch, making it perfect for escaping to the outdoors at the weekend. The tent has a flat front entrance and pre-angled Powerflex® Fiberglass poles allowing you to truly maximise the space within the tent. Included in the design is a pre-attached overdoor canopy which is great for providing cover from both the sun and the rain. Perfect for couples and small families who want to embrace their Spirit of Adventure in the outdoors.

## SPECIFICATION

**PITCHING** ..... All-in-one  
**FLYSHEET** ..... Vango ProTex® 70D polyester 4,000mm  
**INNER** ..... Breathable polyester 190T  
**GROUNDSHEET** ..... Polyethylene  
**POLES** ..... PowerFlex® fibreglass

## FEATURES

- **NEW Expandable tent bag** - oversized wide opening makes it simpler to pack away your tent.
- **Pre-angled poles** - greater internal space and effective bracing against side winds.
- **TBS®II - Tension Band System** - ensures tent performs in adverse conditions.
- **Fully Sewn-in Groundsheet** - providing a bug and draught free environment.
- **Waterproof PE groundsheet** - hardwearing fabric to stand up to the rigours of the most active campers.
- **Mesh flysheet door** - one (or more) entrance has a full mesh door. Provides ventilation and keeps bugs out.
- **Covered entrance** - prevents rain from dripping in to the living area.
- **Cable entry point with tidies** - zipped entry point for power cable, with touch fastener tidies.
- **Lantern Hanging Points** - conveniently positioned to attach your light(s).
- **Lights out inner tent** - darker fabric reduces the amount of early morning light.
- **Toggled inner divider** - flexible options for sleeping or providing increased living space.
- **Toggled privacy curtains** - provides privacy when required, can be rolled away when not in use.
- **High visibility guylines** - easy to see in low light conditions.
- **Weather tested** to the European standard EN5912 by certified test centre.
- **Fire retardant fabrics** - meets European EN5912 safety standard.

## OPTIONAL ADDITIONS



### FOOTPRINT

500 FPNHUDSONB05177  
 600 FPNHUDSONB05181



### UNIVERSAL CARPET

500 / 170 X 310 CPNUNIVERW11G35  
 600 / 170 X 310 CPNUNIVERW11G35



### FAMILY SHELTER

TPNFAMILYH09Z05



HERBAL  
500 shown

## 500

TENHUDSONH09177

**TOTAL WEIGHT** ..... 10.85kg  
**PACKED** ..... 70 x 28 x 22cm  
**PITCHING TIME** ..... 17 mins  
**CARTON QTY** ..... 1  
**STD ORDER QTY** ..... 1

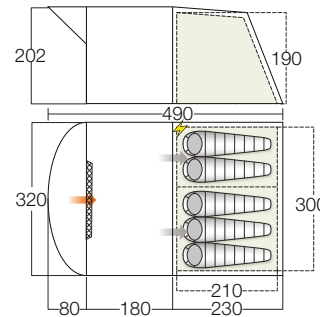

## 600

TENHUDSONH09181

**TOTAL WEIGHT** ..... 17.8kg  
**PACKED** ..... 70 x 33 x 30cm  
**PITCHING TIME** ..... 17 mins  
**CARTON QTY** ..... 1  
**STD ORDER QTY** ..... 1

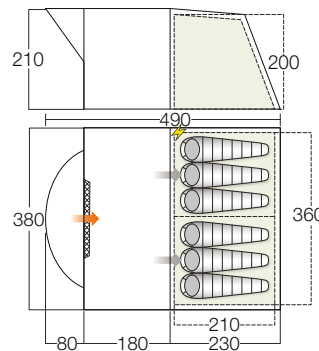

# LANGLEY UPDATED

The Langley is an extremely versatile family tent, allowing you to add on a porch door as an optional addition, perfect for when you need more space for camping equipment or even just to gain more privacy in the front extension. Our oversized vents allow greater ventilation and significantly reduce the chance of condensation building up. Enjoy the luxury of stand up height and toggled curtains & inner divider to get that home from home feel.

## SPECIFICATION

- PITCHING** ..... All-in-one  
**FLYSHEET** ..... Vango ProTex® 70D polyester 4,000mm  
**INNER** ..... Breathable polyester 190T  
**GROUND SHEET** ..... Polyethylene  
**POLES** ..... PowerFlex® fibreglass

## FEATURES

- **NEW Expandable tent bag** - oversized wide opening makes it simpler to pack away your tent.
- **Pre-angled poles** - greater internal space and effective bracing against side winds.
- **TBS®II - Tension Band System** - ensures tent performs in adverse conditions.
- **Fully Sewn-in Groundsheet** - providing a bug and draught free environment.
- **Waterproof PE groundsheet** - hardwearing fabric to stand up to the rigours of the most active campers.
- **Pre-attached extension** - built in front canopy providing generous extra living space.
- **Mesh flysheet door** - a full mesh door provides ventilation and keeps bugs out.
- **Covered entrance** - prevents rain from dripping in to the living area.
- **Cable entry point with tidies** - zipped entry point for power cable, with touch fastener tidies.
- **Double living area** - an extra large living area giving more space for all your camping essentials.
- **Lantern Hanging Points** - conveniently positioned to attach your light(s).
- **Lights out inner tent** - darker fabric reduces the amount of early morning light.
- **Toggled inner divider** - flexible options for sleeping or providing increased living space.
- **Toggled privacy curtains** - provides privacy when required, can be rolled away when not in use.
- **High visibility guylines** - easy to see in low light conditions.
- **Weather tested** to the European standard EN5912 by certified test centre.
- **Fire retardant fabrics** - meets European EN5912 safety standard.

## OPTIONAL ADDITIONS



### FOOTPRINT & EXTENSION GROUND SHEET

400XL / FPNLANGLEB05TAR  
 600XL / FPNLANGLEB05TAQ



### UNIVERSAL CARPET

400XL / 240 x 300 CPNUNIVERW11G28  
 600XL / 260 x 360 CPNUNIVERW11G29



### AVINGTON / LANGLEY XL AWNING

TANAVILANH09THK



### PORCH DOOR

400XL / PDNLANGLEH09TAR  
 600XL / PDNLANGLEH09TAQ



HERBAL  
400XL shown

## 400XL TENLANGLEH09TAR

- TOTAL WEIGHT** ..... 20.20kg  
**PACKED** ..... 70 x 36 x 35cm  
**PITCHING TIME** ..... 20 mins  
**CARTON QTY** ..... 1  
**STD ORDER QTY** ..... 1

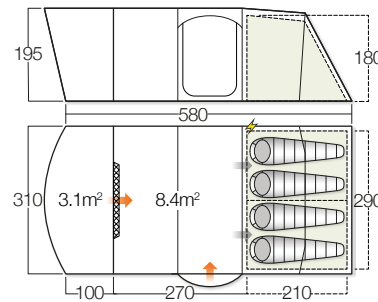

## 600XL TENLANGLEH09TAQ

CORE

- TOTAL WEIGHT** ..... 23.10kg  
**PACKED** ..... 70 x 40 x 30cm  
**PITCHING TIME** ..... 22 mins  
**CARTON QTY** ..... 1  
**STD ORDER QTY** ..... 1

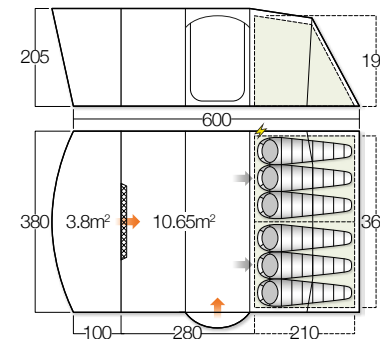

# ORAVA UPDATED

The Orava is everything you need for those long camping holidays with the family. This is an extremely spacious tent with a 5 fibreglass pole tunnel structure and fully flexible built-in front awning, perfect for all of your camping essentials. It boasts an extra-large living area and features Vango's Patented TBS II® system, to ensure the tent performs in adverse weather conditions. This tent is ideal for larger families or those seeking extra room.

## SPECIFICATION

**PITCHING**..... All-in-one  
**FLYSHEET**..... Vango ProTex® 70D polyester 4,000mm  
**INNERS**..... Breathable polyester 190T  
**GROUNDSHEETS**..... Polyethylene  
**POLES**..... PowerFlex® fibreglass

## FEATURES

- **NEW Expandable tent bag** - oversized wide opening makes it simpler to pack away your tent.
- **King Pole Doors** - Integrated eyelets allow optional king poles to prop open doors. Creates a canopy
- **Pre-angled poles** - greater internal space and effective bracing against side winds.
- **TBS®II - Tension Band System** - ensures tent performs in adverse conditions.
- **Fully Sewn-in Groundsheet** - providing a bug and draught free environment.
- **Pre-attached awning** - offers extra covered living space.
- **Toggled privacy curtains** - provides privacy when required, can be rolled away when not in use.
- **Mesh flysheet door** - a full mesh door. Provides ventilation and keeps bugs out.
- **Covered entrance** - prevents rain from dripping in to the living area.
- **Generous king-sized bedrooms** - big enough to fit a double sized airbed or double sleep mat.
- **Cable entry point with tidies** - zipped entry point for power cable, with touch fastener tidies.
- **Double living area** - an extra large living area giving more space for all your camping essentials.
- **Lantern Hanging Points** - conveniently positioned to attach your light(s).
- **Lights out inner tent** - darker fabric reduces the amount of early morning light.
- **Toggled inner divider** - flexible options for sleeping or providing increased living space.
- **High visibility guylines** - easy to see in low light conditions.
- **Weather tested** to the European standard EN5912 by certified test centre.
- **Fire retardant fabrics** - meets European EN5912 safety standard.

## OPTIONAL ADDITIONS



### FOOTPRINT & AWNING G/SHEET

500XL FPNORAVTAB05TAP  
 600XL FPNORAVTAB05TAQ



### UNIVERSAL CARPET

500XL / 260 X 360 CPNUNIVERW11G29  
 600XL / 270 X 430 CPNUNIVERW11G30



### ORAVA SIDE AWNING

TANORAVA H09THJ



### FAMILY WINDBREAK

HERBALTENWINDBRH09Z05



HERBAL  
500XL shown

## 500XL TENORAVA H09TAP

**TOTAL WEIGHT**..... 28.70kg  
**PACKED**..... 70 x 40 x 36cm  
**PITCHING TIME**..... 20 mins  
**CARTON QTY**..... 1  
**STD ORDER QTY**..... 1

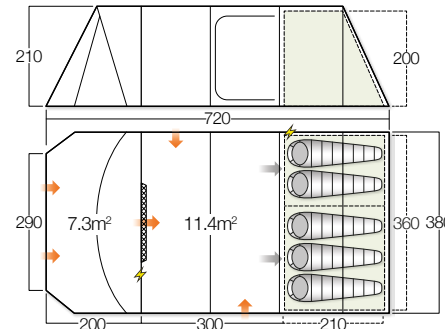

## 600XL TENORAVA H09TAQ



**TOTAL WEIGHT**..... 31.00kg  
**PACKED**..... 73 x 40 x 37cm  
**PITCHING TIME**..... 20 mins  
**CARTON QTY**..... 1  
**STD ORDER QTY**..... 1

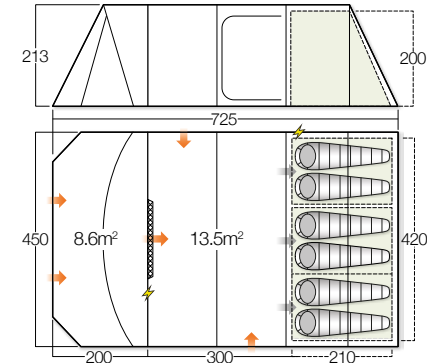

# CASA NEW HERO

The Casa is a true home from home allowing you to personalise the tent to your needs. This large poled family tent has an abundance of space which includes an enclosed porch area, extra-large living room and two super-king bedrooms. Recommended for up to 7 people, with plenty of room to spare. This tent was named Casa because it truly emphasises the homely feel you have within this tent and is perfect to socialise with friends and family, Mi casa es su casa.

## SPECIFICATION

- PITCHING** .....All-in-one  
**FLYSHEET** ..... Vango ProTex® 70D polyester 4,000mm  
**INNER** ..... Breathable polyester 190T  
**GROUND SHEET** ..... Polyethylene  
**POLES** ..... PowerFlex® fibreglass

## FEATURES

- **NEW Expandable tent bag** - oversized wide opening makes it simpler to pack away your tent.
- **NEW Super King bedrooms** - allows camp beds and airbeds to fit with ease for the perfect night's sleep.
- **Pre-angled poles** - achieve greater internal space than with a standard curve
- **TBS®II - Tension Band System** - ensures tent performs in adverse conditions.
- **Fully Sewn-in Groundsheet** - adds to the comfort of your tent by providing a bug and draught free environment
- **Pre-attached extension** - front canopy built into the design of the tent offering generous extra living space.
- **Mesh flysheet door** - entrance has a full mesh door. Provides ventilation and keeps bugs out
- **Covered entrance** - sheltered entrance to your tent which prevents rain from dripping in to the living area
- **Cable entry point with tidies** - zipped entry point for power cable, with touch fastener tidies
- **Double living area** - an extra large living area giving more space for all your camping essentials.
- **Lantern Hanging Points** - conveniently positioned to attach your light(s)
- **Lights out inner tent** - darker fabric reduces the amount of early morning light
- **Toggled inner divider** - flexible options for sleeping or provides increased living space
- **High visibility guylines** - easy to see in low light conditions.
- **Weather tested** to the European standard EN5912 by certified test centre.
- **Fire retardant fabrics** - meets European EN5912 safety standard.



HERBAL  
TENCASA H09Z05

- TOTAL WEIGHT** ..... 30.3kg  
**PACKED** ..... 73 x 40 x 38cm  
**PITCHING TIME** ..... 20 mins  
**CARTON QTY** ..... 1  
**STD ORDER QTY** ..... 1

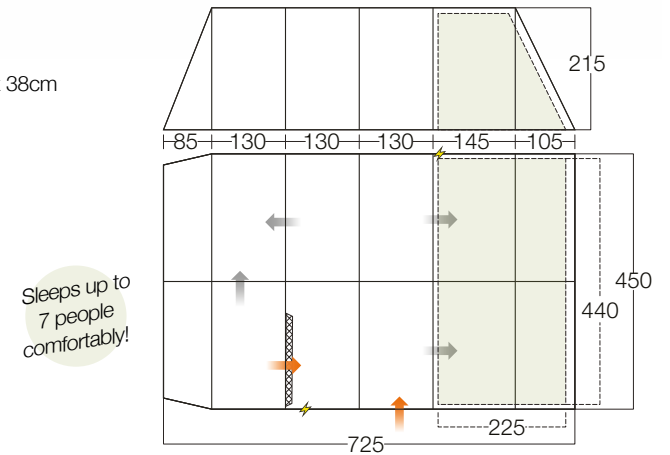

## OPTIONAL ADDITIONS



**FOOTPRINT & EXTENSION G/SHEET**  
FPNCASA B05TAQ



**UNIVERSAL CARPET**  
260 X 360 CPNUIVERW11G29



**FAMILY WINDBREAK**  
HERBALTENWINDBRH09Z05



## FAMILY POLED

### EXCEED PLUS

The Vango Exceed Plus collection is the pinnacle of our poled family tent offering. Using our premier, highly waterproof and durable Vango ProTex® 150 denier or TC Polycotton fabrics, these tents are built to last, whilst being comfortable.

These tents are packed full of excellent features to meet all your camping needs. This includes a fully sewn-in groundsheet to prevent bugs and draughts sneaking in, multiple mesh flysheet doors and all come in our new, expandable tent bag with oversized opening making it easier to pack your tent away after a great family holiday. Our Exceed Plus range is perfect for those family camping holidays, where space and storage are essential.



**FAMILY POLED**

**EXCEED PLUS**



**HAYWARD 600XL**



**ROSEWOOD**

# HAYWARD UPDATED

Featuring Vango's Protex 150D fabric, the Hayward is the ideal tent for any family holiday. The spacious living area combined with the expansive front extension and adjustable bedroom layout of 2/2/2 or 3/3 offers great flexibility. Enjoy the luxury of high ceilings, zipped inner dividers in the bedroom, zipped curtains and a fully sewn-in groundsheet to add to the comfort of your tent.

## SPECIFICATION

**PITCHING** ..... All-in-one  
**FLYSHEET** ..... Vango ProTex® 150D polyester 5,000mm  
**INNER** ..... Breathable polyester 190T  
**GROUNDSHEET** ..... Polyethylene  
**POLES** ..... PowerFlex® Fibreglass

## FEATURES

- **NEW Expandable tent bag** - oversized wide opening makes it simpler to pack away your tent.
- **TBS®II - Tension Band System** - ensures tent performs in adverse conditions.
- **Pre-angled poles** - greater internal space, provides effective bracing against side winds.
- **Pre-attached front extension** - offering generous extra living space.
- **Diamond-Clear PVC windows with zipped privacy curtains** - maximises light and visibility.
- **Fully sewn-in groundsheet** - providing a bug and draught free environment.
- **Cable entry point** - zipped entry point for power cable, with loop and hook ties.
- **Vango AirZone high and low ventilation** - provides maximum airflow and help reduce condensation.
- **Lights-out inner** - helps reduce the amount of early morning light.
- **Pelmet storage** - exclusive to Vango, the Pelmet provides additional storage space, hides the inner tent attachment points and reduces drafts.
- **Zippered inner divider** - flexible options for sleeping or increased living space.
- **Part mesh inner doors** - allows ventilation, whilst keeping bugs out.
- **Multiple lantern hanging points** - conveniently positioned at all living area poles.
- **Line-Lok guyline adjusters** - lightweight, easy to use and will hold firm in windy conditions.
- **Weather tested** to the European standard EN5912 by certified test centre.
- **Fire retardant fabrics** - meets European EN5912 safety standard.



## 600XL TENHAYWARS0DTAQ

**TOTAL WEIGHT** ..... 28.00kg  
**PACKED** ..... 70 x 39 x 37cm  
**PITCHING TIME** ..... 22 mins  
**CARTON QTY** ..... 1  
**STD ORDER QTY** ..... 1

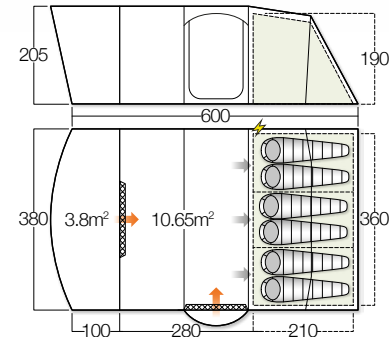

## OPTIONAL ADDITIONS



**FOOTPRINT & EXTENSION G/SHEET**  
FPNHAYWARB05TAQ



**FITTED CARPET**  
CPNHAWYARW11TAQ



**UNIVERSAL CARPET**  
260 x 360 CPNUIVERW11G29



**PORCH DOOR**  
PDNHAYWARS0DTAQ

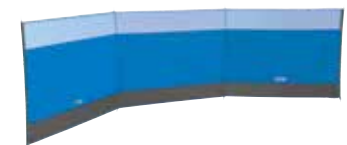

**FAMILY WINDBREAK**  
SKY BLUE TENWINDBRS0DZ05



# ROSEWOOD NEW HERO

New for 2018 the Rosewood is the epitome of boutique Glamping! This Tipi style tent is designed using our deluxe Poly-Cotton fabric and utilises a steal & alloy poled tied arch system which means the space inside isn't restricted by a central pole. The Rosewood also features a pre-attached sun-canopy allowing you to enjoy the most of the summer sun. This tent is a real head turner due to it's classic yet sophisticated design and is perfect for those who are looking to add luxury to their camping experience.

## SPECIFICATION

- PITCHING** ..... Tied Arch System (TAS)  
**FLYSHEET** ..... ProTex® TC polycotton 200g/m<sup>2</sup> (65% cotton/35% polyester)  
**INNERS** ..... ProTex® TC polycotton  
**GROUNDSHEET** ..... Oxford Ripstop Polyester  
**POLES** ..... PowerPlus Steel Poles & PowerLite alloy pole

## FEATURES

- **No central pole** - a Tipi tent, without the inconvenience of a pole in the middle!
- **NEW Expandable tent bag** - oversized wide opening makes it simpler to pack away your tent.
- **Fully Sewn-in Groundsheet** - adds to the comfort of your tent by providing a bug and draught free environment.
- **Pre-attached sun canopy** - provides a great place to relax outside your tent, shelter from sun or the rain or a covered space to store extra kit.
- **Covered entrance** - gives a sheltered entrance to your tent, which prevents rain from dripping in to the living area.
- **Secondary mesh doors on all flysheet doors** - provides ventilation whilst keeping out insects.
- **Cable entry point with tidies** - zipped entry point for power cable, with touch fastener tidies.
- **Lantern Hanging Points** - conveniently positioned to attach your light(s).
- **Toggled privacy divider** - flexible options for sleeping or provides increased living space.
- **Diamond Clear windows** - maximise light and visibility.
- **Toggled privacy curtains** - provides privacy when required, can be rolled away when not in use.
- **Vango AirZone** - high and low level ventilation panels combine to create a comfortable flow of air through the tent.



**NUTMEG**  
TENROSEWON04Z05

- TOTAL WEIGHT** ..... 23.1kg  
**PACKED** ..... 72 x 34 x 34cm  
**PITCHING TIME** ..... 20 mins  
**CARTON QTY** ..... 1  
**STD ORDER QTY** ..... 1

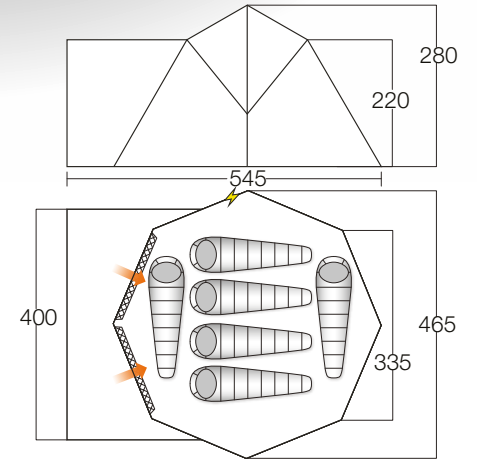

## OPTIONAL ADDITIONS



**FOOTPRINT**  
FPNROSEWOB05Z05



**FITTED CARPET**  
CPNROSEWOW11Z05



**UNIVERSAL CARPET**  
240 X 300 CPNUNIVERW11G28

# WINDBREAKS

## FAMILY WINDBREAK

Featuring robust PowerPlus Steel poles, the Family Windbreak is the perfect addition to your camping essentials and is ideal for using at the beach or beside your tent. With a highly waterproof, durable and reliable fabric, the windbreak can be used for shielding you from the wind, rain or sunshine!

### FEATURES

- Supplied in carry bag
- PowerPlus Steel Poles - Steel poles are used to give maximum strength and stability in many of our tunnel tents.
- Vango ProTex® 70D 4000mm HH flysheet, 4000mm HH - Highly waterproof, durable and reliable fabric.
- High Visibility Guylines - Easy to see in low light conditions.
- Fire retardant fabrics - Meets European EN5912 safety standard

**LENGTH** 435cm    **HEIGHT** 120cm  
**WEIGHT** 2.5kg    **PACKED** 52 x 10 x 10cm  
**STD ORDER QTY** 4



HERBAL  
TENWINDBRH09Z05

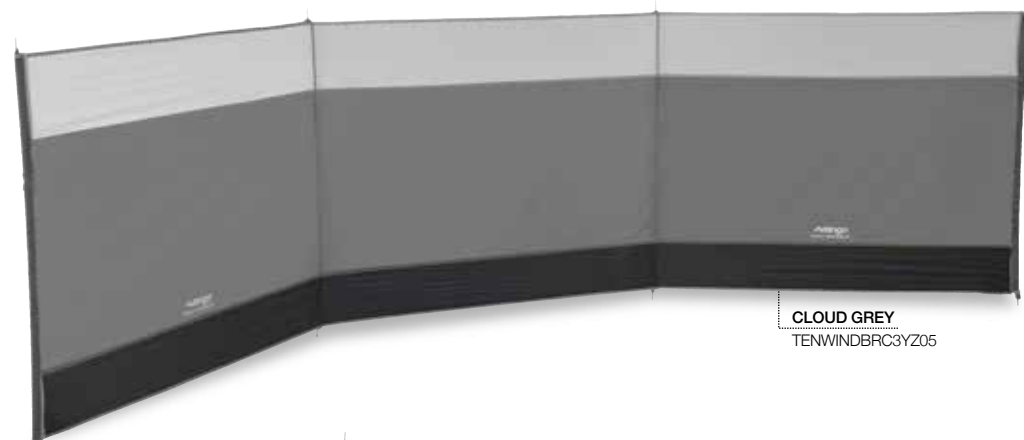

CLOUD GREY  
TENWINDBRC3YZ05

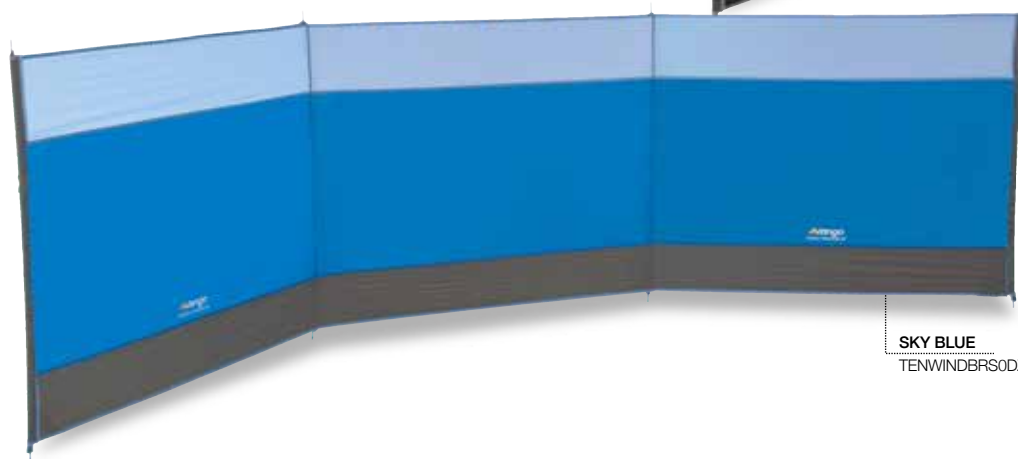

SKY BLUE  
TENWINDBRS0DZ05



## AIRBEAM®

*Our revolutionary AirBeam® tent range was launched back in 2011 and has become the benchmark in air tent technology, trusted by thousands of family campers. This ever-evolving range includes three collections catering for the needs of all family campers through diverse layouts, high-quality fabrics and unique home from home features.*

*The Excel collection introduces consumers to the AirBeam® range and whilst offering exceptional value for money it certainly doesn't fall short in terms of quality and engineering. Featuring our exclusive Protex® 70 denier polyester flysheet, this collection has been redesigned for 2018 and now includes our unique SkyTrack II® hanging system. Don't forget to look out for our exceptional Verona with emperor bedrooms .*

*If you are looking for even greater features and an increase in fabric specification then look no further than our Exclusive collection which has been designed using our vibrant sky blue colour available in our fantastic Protex® 150D fabric. This range also features our largest AirBeam® tent with our impressive podded style Diablo 1200XL, a sure winner in 2017.*

*At the top of our AirBeam® range is our Elite collection which is truly the epitome of luxury family camping. This collection features the very best in tent fabrics and unique features. This year we have introduced the exquisite Serenity which is set to revolutionise tent design through its unique layout.*

*Finally, along with our great additions such as porch doors, awning's and carpets. For 2018, we are launching our new SkySheild™, SkyLiners™ and SkyTrack II® storage accessories, allowing campers to add extra comfort to their tent making it a true home from home.*

### EXCEL

Lightweight, compact,  
pack size optimised

### EXCLUSIVE

Packed full of features

### ELITE

The ultimate luxury

# AIRBEAM® TENT ADDITIONS

	TENT	STATUS	AWNING	AWNING ZIP ATTACHMENT	FITTED CARPET	UNIVERSAL CARPET	FOOTPRINT	SKY SHIELD	SKY LINER	PORCH DOOR	SPARE TUBE
EXCEL	AirHub Hex	Updated	-	-	-	240 x 270cm	-	-	-	-	730 x 10
	Capri 400	Updated	-	No	-	130 x 240cm	Capri 400 & Extension Groundsheet	✓	✓	✓	550 x 10 & 465 x 10
	Capri 500	Updated	-	No	-	140 x 320 cm	Capri 500 & Extension Groundsheet	✓	✓	✓	600 x 10 & 555 x 10
	Capri 800	New	Capri 800 Side Awning	No	-	240 x 270cm	Capri 800	✓	✓	-	600 x 10 & 555 x 10
	Santo	New	Family Shelter	No	-	130 x 300cm	Santo	✓	✓	-	600 x 10 & 555 x 10
	Amalfi 500	New	Family Shelter	No	-	170 x 310cm	Hudson / Amalfi 500	✓	✓	-	655 x 10
	Amalfi 600	New	Family Shelter	No	-	170 x 310cm	Hudson/ Amalfi 600	✓	✓	-	655 x 10
	Capri 400XL	Updated	Capri XL Side Awning	No	-	230 x 210cm	Capri 400XL & Extension Groundsheet	✓	✓	✓	555 x 10
	Capri 500XL	Updated	Capri XL Side Awning	No	-	240 x 300cm	Capri 500XL & Extension Groundsheet	✓	✓	✓	655 x 10 & 600 x 10
	Capri 600XL	Updated	Capri XL Side Awning	No	-	260 x 360cm	Capri 600XL & Extension Groundsheet	✓	✓	✓	655 x 10
	Taiga 500XL	Updated	Taiga Side Awning	No	-	260 x 360cm	Orava/Taiga & Awning Groundsheet	✓	✓	-	685 x 10
	Taiga 600XL	Updated	Taiga Side Awning	No	-	270 x 430cm	Orava/Taiga 600XL & Awning Groundsheet	✓	✓	-	708 x 10
	Verona	New	-	-	SERENITY FITS	260 x 360cm	Verona/Serenity & Awning Groundsheet	✓	✓	-	735 x 13 & 685 x 13
	EXCLUSIVE	Edoras 400XL	Updated	AirBeam Exclusive Front Awning 400	Yes	✓	240 x 300cm	Edoras 400XL & Extension Groundsheet	✓	✓	✓
Edoras 500XL		Updated	AirBeam Exclusive Front Awning 500	Yes	✓	260 x 360cm	Edoras 500XL & Extension Groundsheet	✓	✓	✓	655 x 10
Edoras 600XL		Updated	AirBeam Exclusive Front Awning 600 & Exclusive Sun Canopy	Yes	✓	270 x 430cm	Edoras 600XL & Extension Groundsheet	✓	✓	✓	685 x 10
Rivendale 500XL		Updated	AirBeam Exclusive Front Awning 500	Yes	✓	260 x 360cm	Rivendale 500XL & Awning Groundsheet	✓	✓	-	655 x 10
Rivendale 800XL		Updated	AirBeam Exclusive Front Awning 600 & Exclusive Sun Canopy	Yes	✓	270 x 430cm	Rivendale 800XL & Awning Groundsheet	✓	✓	-	685 x 10
Diablo 800XL		Updated	AirBeam Diablo Front Awning	Yes	✓	260 x 360cm	Diablo 800XL & Extension Groundsheet	✓	-	✓	719 x 13 & 600 x 10
Diablo 1200XL		Updated	AirBeam Diablo Front Awning	Yes	✓	260 x 360cm	Diablo 1200XL & Extension Groundsheet	✓	-	✓	719 x 13 & 600 x 10
Illusion 500XL		Updated	Elite Awning 500XL & Elite Sun Canopy 5	Yes	✓	260 x 360cm	Illusion 500XL & Awning Groundsheet	✓	✓	✓	685 x 13
ELITE	Illusion 800XL	Updated	Elite Awning 800 & Elite Sun Canopy 8	Yes	✓	270 x 430cm	Illusion 800XL & Awning Groundsheet	✓	✓	✓	685 x 13
	Maritsa 600XL	Updated	Maritsa Awning & Maritsa Sun Canopy	Yes	✓	240 x 270cm	Maritsa 600XL & Awning Groundsheet	✓	✓	-	735 x 13 & 615 x 13
	Serenity	New	-	-	✓	260 x 360cm	Verona/Serenity & Awning Groundsheet	✓	✓	-	685 x 13
	Inspire 800XXL	Updated	Elite Awning 800 & Elite Sun Canopy 8	Yes	✓	270 x 430cm	Inspire 800XXL & Extension Groundsheet	✓	✓	✓	685 x 13
POLYCOTTON	Solace TC 400	Updated	Awning Solace TC 400	Yes	✓	130 x 240cm	Solace TC 400 & Extension Groundsheet	-	✓	✓	595 x 13
	Illusion TC 500XL	Updated	Sun Canopy Illusion 500XL TC	Yes	✓	260 x 360cm	Illusion 500XL & Awning Groundsheet	-	✓	-	685 x 13
	Illusion TC 800XL	Updated	Sun Canopy Illusion 800XL TC	Yes	✓	270 x 430cm	Illusion 800XL & Awning Groundsheet	-	✓	-	685 x 13
	Maritsa TC 600XL	New	Maritsa TC Sun Canopy	Yes	✓	240 x 270cm	Maritsa 600XL & Awning Groundsheet	✓	✓	-	735 x 13 & 615 x 13

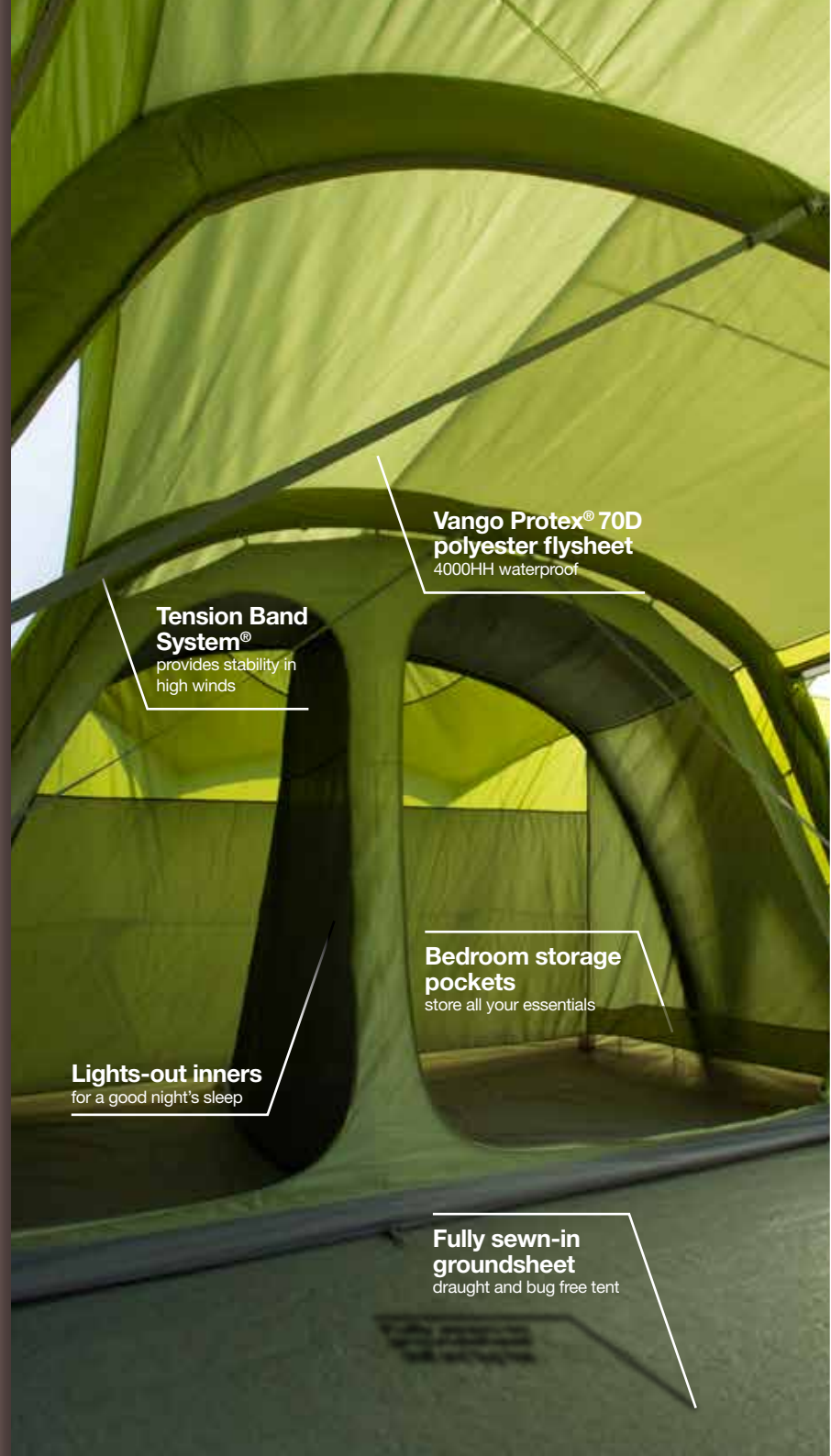

**Vango Protex® 70D polyester flysheet**  
4000HH waterproof

**Tension Band System®**  
provides stability in high winds

**Bedroom storage pockets**  
store all your essentials

**Lights-out inners**  
for a good night's sleep

**Fully sewn-in groundsheet**  
draught and bug free tent



**Covered entrance**  
\*on some models

## EXCEL

Now featuring a modern sophisticated design our Excel Range is ideal for weekends away or longer camping holiday, our AirBeam® Excel collection ranges from 4 to 8 person family tents.

Using our exclusive Vango ProTex 70D fabric (4000HH), our Excel tents are highly durable, reliable and waterproof meaning the inside of the tent will stay dry and be protected from the elements.

Excel tents now feature our innovative hanging SkyTrackII™ System, pre -angled beam's to fully maximise head height and our brand new expandable tent bag taking the stress out of packing your tent away after a memorable camping holiday.



**AIRBEAM®**

**EXCEL**



**AIRHUB HEX**



**CAPRI 400**



**CAPRI 500**



**CAPRI 800XL**



**SANTO**



**AMALFI 500**



**AMALFI 600**



**CAPRI 400XL**



**CAPRI 500XL**



**CAPRI 600XL**



**TAIGA 500XL**



**TAIGA 600XL**



**VERONA**

# AIRHUB HEX



The award winning AirHub Hex gazebo tent offers additional communal space for any occasion, be that on the campsite or in the garden. Available in both Herbal green and Smoke grey, this fantastic event shelter will meet the needs of campers, motor home users or caravan owners alike, who are looking for additional living space. With a single inflation point, yet three valves, AirHub Hex is fast and easy to inflate and deflate. All 6 sides come built into the shelter, including 3 large full side doors and 6 mesh windows, AirHub Hex is ready for any occasion

## SPECIFICATION

**PITCHING** ..... Vango AirBeam® Technology  
**BODY** ..... ProTex® 70D 4,000mm polyester  
**GROUND SHEET** ..... Polyethylene (removable)

## FEATURES

- **Sky Track** - A flexible hanging system which allows you to easily attach lighting or storage. The SkyTrack system truly allows you to design your tent to suit your needs
- **Expandable Tent Bag** - An expandable tent bag with an oversized wide opening makes it simpler to pack away your tent
- **Pre-Angled Beams** - Achieve greater internal space than with a standard curve. Provides effective bracing against winds
- **Linked-in Groundsheet** - Easy to clean groundsheet that can be attached or detached from the living area.
- **Double Zip Door** - provides additional flexibility by allowing the top of the door to be opened slightly for increased ventilation
- **Zippered Privacy Curtains** - Simple and quick to use, zip curtains allow varying levels of opening.
- **Easy Access Door** - Allowing you to effortlessly enter your tent without needing to step over the entrance.
- **Pump Included** - Double action AirBeam pump included
- **High Visibility Guylines** - Easy to see in low light conditions.
- **Fire retardant fabrics** - Meets European EN5912 safety standard



TENAIRHUBH09Z05 ● HERBAL

TENAIRHUBS0YZ05 ● SMOKE

**TOTAL WEIGHT** ..... 13.80kg

**PACKED** ..... 69 x 37 x 37cm

**PITCHING TIME** ..... 5 mins

**CARTON QTY** ..... 1

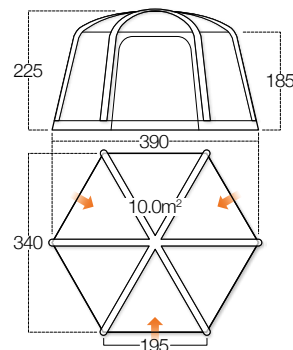

**UNIVERSAL CARPET**  
240 X 270CM

# CAPRI UPDATED

A firm favourite with campers, the award-winning Capri is a great value weekend tent, perfect for smaller families and couples. This tent offers the perfect balance between light and space thanks to its generous bedrooms, stand-up height and airy living room. The tent also features large windows, a side entrance and a built-in front extension to create a multifunctional outside area which is ideal for relaxing - exactly what a holiday is for!

## SPECIFICATION

**PITCHING** ..... Vango AirBeam® Technology  
**FLYSHEET** ..... ProTex® 70D 4,000mm polyester  
**INNER** ..... Breathable polyester  
**GROUND SHEET** ..... Fully sewn in waterproof PE groundsheet

## FEATURES

- **Sky Track II** - A flexible hanging system which allows you to easily attach lighting, storage or our new SkyLiners. The SkyTrack system truly allows you to design your tent to suit your needs
- **Expandable Tent Bag** - An expandable tent bag with an oversized wide opening makes it simpler to pack away your tent.
- **TBS II** - Patented Vango TBS®II Tension Band System ensures tent performs in adverse conditions, especially in strong, changeable winds.
- **Mesh Flysheet Door** - One entrance has a full mesh door which provides ventilation and keeps bugs out
- **Sewn In Groundsheet** - adds to the comfort of your tent by keeping a bug and draught free environment
- **Double Zip Door** - provides additional flexibility by allowing the top of the door to be opened slightly for increased ventilation
- **Lights Out Inner Tent** - Darker fabric reduces the amount of early morning light
- **Covered Entrance** - gives a sheltered entrance to your tent, which prevents rain from dripping in to the living area
- **Low & High Ventilation** combine to create a comfortable flow of air through the tent
- **High Visibility Guylines** - Easy to see in low light conditions.



HERBAL  
400 shown

**400** TENCAPRI H09173  
**TOTAL WEIGHT** ..... 14.80kg  
**PACKED** ..... 64 x 31 x 34cm  
**PITCHING TIME** ..... 8 mins  
**CARTON QTY** ..... 1

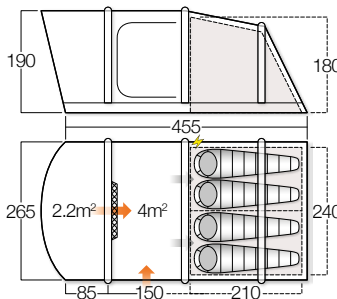

**500** TENCAPRI H09177  
**TOTAL WEIGHT** ..... 16.00kg  
**PACKED** ..... 70 x 36 x 33cm  
**PITCHING TIME** ..... 8 mins  
**CARTON QTY** ..... 1

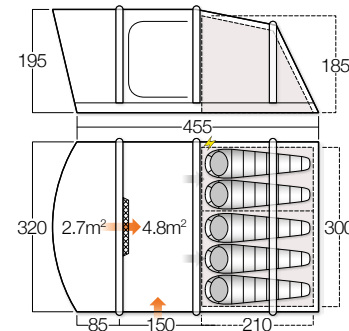

## OPTIONAL ADDITIONS



**SKY SHIELD**  
 400 SSNCAPRI H09173  
 500 SSNCAPRI H09184



**PORCH DOOR**  
 400 PDNCAPRI H09173  
 500 PDNCAPRI H09177



**UNIVERSAL CARPET**  
 400 / 130 x 240 CPNUNIVERW11G24  
 500 / 130 x 300 CPNUNIVERW11G25



**FOOTPRINT & EXTENSION G/SHEET**  
 400 FPNCAPRI B05173  
 500 FPNCAPRI B05177



# CAPRI NEW

The Capri 800 is great for larger families with older kids. This is a generous, 8 person AirBeam® tent, which utilises a vis-a-vis layout, meaning it has two sleeping areas positioned at either end of the tent and a large central living area in the middle.

This lets children have some independence, while the parents can have a little peace and quiet! The Capri is an extremely practical tent for longer breaks.

## SPECIFICATION

- PITCHING** ..... Vango AirBeam® Technology  
**FLYSHEET** ..... ProTex® 70D 4,000mm polyester  
**INNER** ..... Breathable polyester  
**GROUND SHEET** ..... Fully sewn in waterproof PE groundsheet

## FEATURES

- **Sky Track II** - A flexible hanging system which allows you to easily attach lighting, storage or our new SkyLiners. The SkyTrack system truly allows you to design your tent to suit your needs
- **Expandable Tent Bag** - An expandable tent bag with an oversized wide opening makes it simpler to pack away your tent
- **Pre-Angled Beams** - Achieve greater internal space than with a standard curve. Provides effective bracing against winds
- **TBS II** - Patented Vango TBS®II Tension Band System ensures tent performs in adverse conditions, especially in strong, changeable winds.
- **Mesh Flysheet Door** - One entrance has a full mesh door which provides ventilation and keeps bugs out
- **Sewn In Groundsheet** - adds to the comfort of your tent by providing a bug and draught free environment.
- **Double Zip Door** - provides additional flexibility by allowing the top of the door to be opened slightly for increased ventilation
- **Lights Out Inner Tent** - Darker fabric reduces the amount of early morning light
- **Covered entrance** - gives a sheltered entrance to your tent, which prevents rain from dripping in to the living area
- **Low & High Ventilation** - Combine to create a comfortable flow of air through the tent, reducing condensation



## 800XL TENCAPRI H09184 CORE

- TOTAL WEIGHT** ..... 22.20kg  
**PACKED** ..... 70 x 44 x 40cm  
**PITCHING TIME** ..... 10 mins  
**CARTON QTY** ..... 1

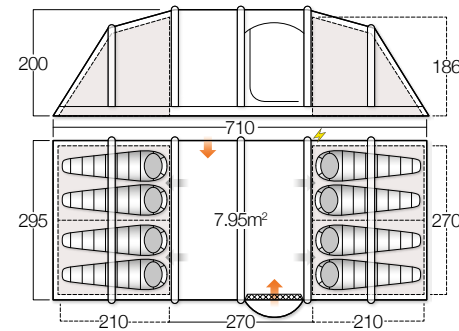

## OPTIONAL ADDITIONS



**CAPRI 800 SIDE AWNING**  
 STD TANCAPRI H09THG



**SKY SHIELD**  
 SSNCAPRI H09184



**SKY LINER**  
 400 TEMSKYLIN0HU173  
 500 TEMSKYLIN0HU177



**UNIVERSAL CARPET**  
 240 x 270 CPNUNIVERW11G27



**FOOTPRINT**  
 FPNCAPRI B05184

# SANTO NEW

Designed to provide a comfortable, but quick and easy to pitch weekend tent, the Santo is the ideal model for those seeking the convenience of an inflatable tent at a more affordable price point. Its ergonomic design means it has a comparatively small pack size and is surprisingly light for a family tent. Despite its compact packed size, the Santo offers a full stand up height living room, with two king size bedrooms, that can be converted to one very large bedroom if required.

## SPECIFICATION

**PITCHING** ..... Vango AirBeam® Technology  
**FLYSHEET** ..... Vango Protex® 70D 4000mm HH polyester  
**INNER** ..... Breathable polyester  
**GROUNDSHEET** ..... Fully sewn in waterproof PE groundsheet

## FEATURES

- **Sky Track II** - A flexible hanging system which allows you to easily attach lighting, storage or our new SkyLiners. The SkyTrack system truly allows you to design your tent to suit your needs
- **Expandable Tent Bag** - An expandable tent bag with an oversized wide opening makes it simpler to pack away your tent
- **King Sized Bedrooms** - Generous king-sized bedrooms - big enough to fit a double sized airbed or double sleep mat
- **Pre-Angled Beams** - Achieve greater internal space than with a standard curve. Provides effective bracing against winds
- **TBS II** - Patented Vango TBS®II Tension Band System ensures tent performs in adverse conditions, especially in strong, changeable winds.
- **Mesh Flysheet Door** - entrance has a full mesh door which provides ventilation and keeps bugs out
- **Sewn In Groundsheet** - adds to the comfort of your tent by providing a bug and draught free environment.
- **Flexible door step** - An adaptable door step which can easily be dropped to ground level allowing you to effortlessly enter your tent without needing to step over the entrance.
- **Lights Out Inner Tent** - Darker fabric reduces the amount of early morning light
- **Low & High Ventilation** - Combine to create a comfortable flow of air through the tent, reducing condensation



TENSANTO H09Z05

**TOTAL WEIGHT** ..... 15.5kg  
**PACKED** ..... 67 x 35 x 34cm  
**PITCHING TIME** ..... 8 mins  
**CARTON QTY** ..... 1  
**STD ORDER QTY** ..... 1

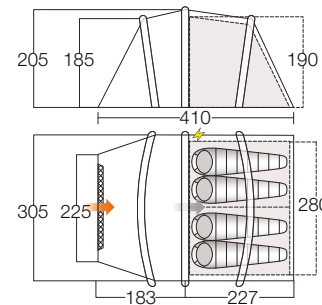

## OPTIONAL ADDITIONS



**SKY SHIELD**  
SSNSANTO H09173



**FAMILY SHELTER**  
TPNFAMILYH09Z05



**SKY LINER**  
SYNSANTO H09173



**UNIVERSAL CARPET**  
130 x 240 CPNUUNIVERW11G24



**FOOTPRINT**  
FPNSANTO B05173

# AMALFI NEW

With a highly contemporary design, providing a new look to the Vango AirBeam collection, the Amalfi is ideal for those seeking a quick pitch weekend or short break holiday tent. Its distinctive flat front, that optimises internal living space, is protected by a wide shelter canopy that will help keep the rain out. With huge diamond clear windows flooding light into the deceptively wide and high living area, this tent provides a homely feel with lots of space to stretch out.

## SPECIFICATION

**PITCHING** ..... Vango AirBeam® Technology  
**FLYSHEET** ..... Vango Protex® 70D polyester 4000mm HH  
**INNER** ..... Breathable polyester  
**GROUND SHEET** ..... Fully sewn-in waterproof PE groundsheet

## FEATURES

- **Sky Track II** - A flexible hanging system which allows you to easily attach lighting, storage or our new SkyLiners. The SkyTrack system truly allows you to design your tent to suit your needs
- **Expandable Tent Bag** - An expandable tent bag with an oversized wide opening makes it simpler to pack away your tent
- **Pre-Angled Beams** - Achieve greater internal space than with a standard curve. Provides effective bracing against winds
- **TBS II** - Patented Vango TBS®II Tension Band System ensures tent performs in adverse conditions, especially in strong, changeable winds.
- **Mesh Flysheet Door** - One entrance has a full mesh door which provides ventilation and keeps bugs out
- **Sewn In Groundsheet** - adds to the comfort of your tent by providing a bug and draught free environment.
- **Double Zip Door** - provides additional flexibility by allowing the top of the door to be opened slightly for increased ventilation
- **Lights Out Inner Tent** - Darker fabric reduces the amount of early morning light
- **Covered entrance** - gives a sheltered entrance to your tent, which prevents rain from dripping in to the living area
- **Low & High Ventilation** - Combine to create a comfortable flow of air through the tent, reducing condensation



**500** TENAMALFIH09177

**TOTAL WEIGHT** ..... 17.6kg  
**PACKED** ..... 70 x 36 x 35cm  
**PITCHING TIME** ..... 10 mins  
**CARTON QTY** ..... 1  
**STD ORDER QTY** ..... 1

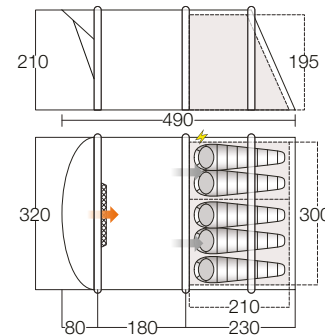

**600** TENAMALFIH09181 HERO CORE

**TOTAL WEIGHT** ..... 19.1kg  
**PACKED** ..... 73 x 38 x 38cm  
**PITCHING TIME** ..... 10 mins  
**CARTON QTY** ..... 1  
**STD ORDER QTY** ..... 1

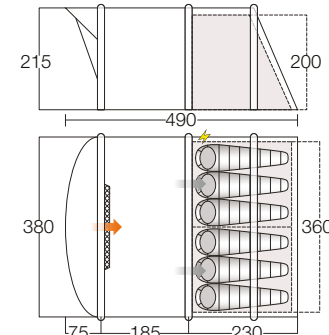

## OPTIONAL ADDITIONS



**SKY SHIELD**  
 400 SSNAMALFIH09177  
 500 SSNAMALFIH09181



**FAMILY SHELTER**  
 TEMPORCHD0HU177



**SKY LINER**  
 400 TEMSKYLIN0HU173  
 500 TEMSKYLIN0HU177



**UNIVERSAL CARPET**  
 500 / 130 x 240 CPNUNIVERW11G24  
 600 / 130 x 300 CPNUNIVERW11G25



**FOOTPRINT**  
 400  
 500

# CAPRI XL UPDATED

A firm favourite with campers, the award-winning Capri is a great value weekend tent, perfect for smaller families and couples. This tent offers the perfect balance between light and space thanks to its generous bedrooms, stand-up height and airy living room. The tent also features large windows, a side entrance and a built-in front extension to create a multifunctional outside area which is ideal for relaxing - exactly what a holiday is for!

## SPECIFICATION

**PITCHING** ..... Vango AirBeam® Technology  
**FLYSHEET** ..... ProTex® 70D 4,000mm polyester  
**INNER** ..... Breathable polyester  
**GROUND SHEET** ..... Fully sewn-in waterproof PE groundsheet

## FEATURES

- **Sky Track II** - A flexible hanging system which allows you to easily attach lighting, storage or our new SkyLiners. The SkyTrack system truly allows you to design your tent to suit your needs
- **Expandable Tent Bag** - An expandable tent bag with an oversized wide opening makes it simpler to pack away your tent
- **Pre-Angled Beams** - Achieve greater internal space than with a standard curve. Provides effective bracing against winds
- **TBS II** - Patented Vango TBS®II Tension Band System ensures tent performs in adverse conditions, especially in strong, changeable winds.
- **Mesh Flysheet Door** - One entrance has a full mesh door which provides ventilation and keeps bugs out
- **Sewn In Groundsheet** - adds to the comfort of your tent by providing a bug and draught free environment.
- **Double Zip Door** - provides additional flexibility by allowing the top of the door to be opened slightly for increased ventilation
- **Lights Out Inner Tent** - Darker fabric reduces the amount of early morning light
- **Covered entrance** - gives a sheltered entrance to your tent, which prevents rain from dripping in to the living area
- **Low & High Ventilation** - Combine to create a comfortable flow of air through the tent, reducing condensation



HERBAL  
500 shown

### 400 TENCAPRI H09TAR

**TOTAL WEIGHT** ..... 19.75kg  
**PACKED** ..... 70 x 41 x 36cm  
**PITCHING TIME** ..... 10 mins  
**CARTON QTY** ..... 1

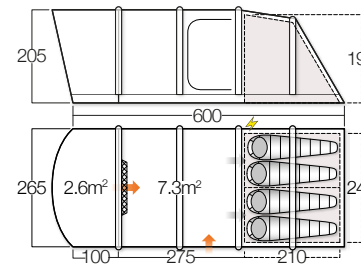

### 500 TENCAPRI H09TAP CORE

**TOTAL WEIGHT** ..... 21.40kg  
**PACKED** ..... 70 x 43 x 38cm  
**PITCHING TIME** ..... 10 mins  
**CARTON QTY** ..... 1

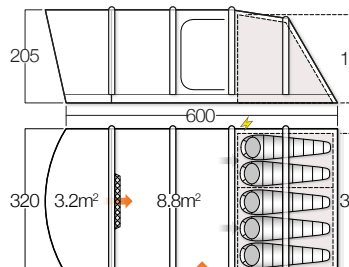

### 600 TENCAPRI H09TAQ CORE

**TOTAL WEIGHT** ..... 23.00kg  
**PACKED** ..... 70 x 45 x 40cm  
**PITCHING TIME** ..... 10 mins  
**CARTON QTY** ..... 1

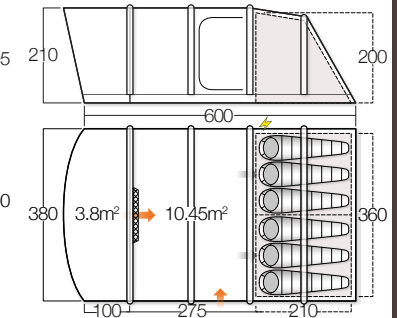

## OPTIONAL ADDITIONS



**CAPRI XL SIDE AWNING**  
STD TANCAPRI H09THH



**PORCH DOOR**  
400 PDNCAPRI H09TAP  
500 PDNCAPRI H09TAQ  
600 PDNCAPRI H09TAR



**SKY SHIELD**  
400 SSNCAPRI H09177  
500 SSNCAPRI H09TAP  
600 SSNCAPRI H09TAQ



**SKY LINER**  
400 SYNCAPRI H09TAR  
500 SYNCAPRI H09TAP  
600 SYNCAPRI H09TAQ



**UNIVERSAL CARPET**  
400 / 230 x 210 CPNUNIVERW11G26  
500 / 240 x 300 CPNUNIVERW11G28  
600 / 260 x 360 CPNUNIVERW11G29



**FOOTPRINT & EXTENSION G/SHEET**  
400 FPNCAPRI B05TAR  
500 FPNCAPRI B05TAP  
600 FPNCAPRI B05TAQ

# TAIGA UPDATED

The Taiga is a great value AirBeam® tent packed full of features! It is perfect for families looking to go on longer camping breaks. The Taiga offers a fantastic multi-functional front awning with two doors which can be opened separately and king poled to increase your living space even further. The tent also features two spacious king size bedrooms with lights-out inners, and a huge living area to enjoy time with friends and family in the evening.



HERBAL  
500XL shown

## SPECIFICATION

- PITCHING** ..... Vango AirBeam® Technology  
**FLYSHEET** ..... ProTex® 70D 4,000mm polyester  
**INNERS** ..... Breathable polyester  
**GROUND SHEETS** ..... Fully sewn-in waterproof PE groundsheet

## FEATURES

- **Sky Track II** - A flexible hanging system which allows you to easily attach lighting, storage or our new SkyLiners. The SkyTrack system truly allows you to design your tent to suit your needs
- **Expandable Tent Bag** - An expandable tent bag with an oversized wide opening makes it simpler to pack away your tent
- **High Cable Entry** - High cable entry on the internal wall allows for increased flexibility on how to feed power cables into the tent or awning
- **King Sized Bedrooms** - Generous king-sized bedrooms - big enough to fit a double sized airbed or double sleep mat
- **Pre-angled Beams** - Achieve greater internal space than with a standard curve. Provides effective bracing against winds
- **TBS II** - Patented Vango TBS®II Tension Band System ensures tent performs in adverse conditions, especially in strong, changeable winds.
- **Mesh FLYSHEET DOOR** - One entrance has a full mesh door which provides ventilation and keeps bugs out
- **Sewn In Groundsheet** - adds to the comfort of your tent by providing a bug and draught free environment.
- **Lights Out Inner Tent** - Darker fabric reduces the amount of early morning light
- **Low & High Ventilation** - Combine to create a comfortable flow of air through the tent, reducing condensation

## 500XL TENTAIGA H09TAP

- TOTAL WEIGHT** ..... 26.90kg  
**PACKED** ..... 70 x 42 x 41cm  
**PITCHING TIME** ..... 10 mins  
**CARTON QTY** ..... 1

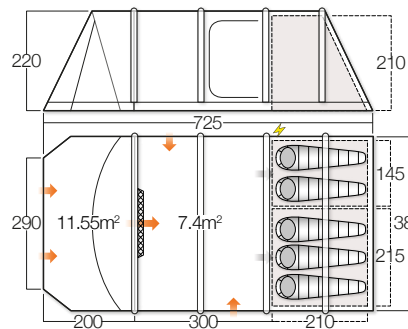

## 600XL TENTAIGA H09TAQ



- TOTAL WEIGHT** ..... 29.50kg  
**PACKED** ..... 70 x 44 x 43cm  
**PITCHING TIME** ..... 10 mins  
**CARTON QTY** ..... 1

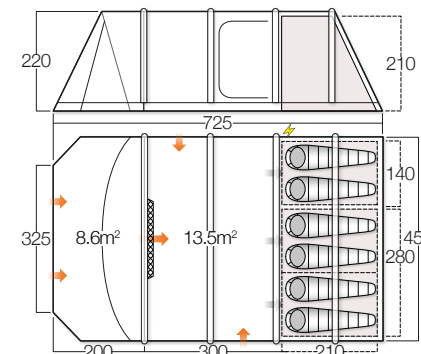

## OPTIONAL ADDITIONS



**TAIGA SIDE AWNING**  
TANTAIGA H09THJ



**SKY LINER**  
500XL SSNTAIGA H09TAP  
600XL SSNTAIGA H09TAQ



**UNIVERSAL CARPET**  
500XL / 260 x 360 CPNUNIVERW11G29  
600XL / 270 x 430 CPNUNIVERW11G30



**FOOTPRINT & AWNING G/SHEET**  
500XL  
600XL



**SKY SHIELD**  
500XL SSNTAIGA H09TAQ  
600XL SSNTAIGA H09TAP

# VERONA NEW HERO

This tent has been designed with space as a priority and it features some truly innovative designs. At the front of the Verona is a built-in awning that provides a bright and airy conservatory space and beyond this is the fantastic living room with huge windows, a covered entrance on one side and double doors on the other, offering a plethora of choice. To compliment the scale of the living space we have introduced the all new Emperor bedrooms which provide full stand up height throughout and lots of space for beds, storage and bedside tables. These enormous bedrooms not only feature doors from the living room, but also at the rear opening into unique storage area.

## SPECIFICATION

**PITCHING** ..... Vango AirBeam® Technology  
**FLYSHEET** ..... Vango Protex® 70D 4000mm HH  
**INNER** ..... Breathable polyester  
**GROUND SHEET** ..... Fully sewn-in waterproof PE groundsheet

## FEATURES

- **Sky Track II** - A flexible hanging system which allows you to easily attach lighting, storage or our new SkyLiners. The SkyTrack system truly allows you to design your tent to suit your needs
- **Expandable Tent Bag** - An expandable tent bag with an oversized wide opening makes it simpler to pack away your tent
- **High Cable Entry** - High cable entry on the internal wall allows for increased flexibility on how to feed power cables into the tent or awning
- **Emperor Bedrooms** - Our superior Emperor bedrooms truly maximise the bedroom space within your tent, perfect for a camp-bed as well as a bed side table for that ultimate home from home feel.
- **Sky Track Bedroom** - The additional bedroom can be hung using our innovative SkyTrack® System, providing flexibility for how many people can sleep in the tent
- **Conservatory style pre-attached awning**
- **3 function doors** - entrance, window, mesh layer
- **Rear door for added flexibility, functionality and safety**
- **Ensuite or storage area at the rear of the tent**
- **Flexible door step** - An adaptable door step which can easily be dropped to ground level allowing you to effortlessly enter your tent without needing to step over the entrance.



HERBAL

TENVERONAH09TAQ

**TOTAL WEIGHT** ..... 39.7kg  
**PACKED** ..... 78 x 54 x 53cm  
**PITCHING TIME** ..... 12 mins  
**CARTON QTY** ..... 1  
**STD ORDER QTY** ..... 1

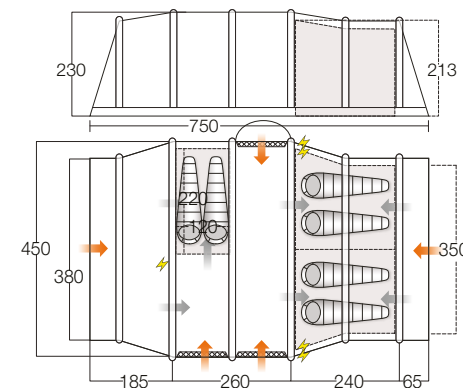

## OPTIONAL ADDITIONS



**SKY SHIELD**  
SSNVERSERH09TAQ



**SKY LINER**  
SYNVERONAH09TAQ



**UNIVERSAL CARPET**  
130 x 240 CPNUNIVERW11G24



**FOOTPRINT & AWNING G/SHEET**  
FPNSERENIB05TAQ



**AIRBEAM®**

## **EXCLUSIVE**

The AirBeam® Exclusive collection includes a range of tents which will accommodate 4 to 12 people comfortably.

Designed in a striking sky blue colour palette, our Exclusive range of tents are constructed using our highly waterproof and durable fabric – 150 denier (5000HH) so you won't have to worry about the rain dampening your holiday spirit!

We know that space is important, which is why we have designed our Exclusive range to maximise internal space to suit all your outdoor needs, including king-sized bedrooms, multiple entry points, additional storage space and our innovative SkyTrack® II hanging system. Furthermore, The Exclusive range now comes with our new expandable tent bags making it even easier to pack away your tent after a memorable camping holiday.



AIRBEAM®

**EXCLUSIVE**



EDORAS 400XL



EDORAS 500XL



EDORAS 600XL



RIVENDALE 500XL



RIVENDALE 800XL



DIABLO 800XL



DIABLO 1200XL



# EDORAS UPDATED

The Edoras is perfect for campers who are looking for a quick to pitch tent that offers a little extra. Summer campers, in particular, will benefit from the grand front extension which can be used for socialising in the great outdoors or to give shade from bright sunlight. The flat entrance and pre-angled AirBeams® maximise the useable internal space, creating more room for seating or storage.

## SPECIFICATION

**PITCHING**.....Vango AirBeam® Technology  
**FLYSHEET**.....ProTex® 150D 5,000mm polyester  
**INNERS**.....Breathable polyester  
**GROUNDSHEETS**..... Fully sewn-in waterproof PE groundsheet

## FEATURES

- **Sky Track II** - A flexible hanging system which allows you to easily attach lighting, storage or our new SkyLiners. The SkyTrack system truly allows you to design your tent to suit your needs
- **Expandable Tent Bag** - An expandable tent bag with an oversized wide opening makes it simpler to pack away your tent
- **3 in 1 Bedroom** - Two zipped dividers create three separate bedrooms to sleep 6. These dividers can be removed to completely open up the inner tent into one room
- **King Sized Bedrooms** - Generous king-sized bedrooms - big enough to fit a double sized airbed or double sleep mat
- **Flysheet Mesh Doors** - Secondary mesh doors on all flysheet doors - Provides ventilation whilst keeping insects outside
- **Super Zips on Flysheet Doors** - Stronger, smoother and more durable zips, ideal for the heavier weight flysheet fabric
- **Living Area Pockets** - Conveniently positioned for storing essentials
- **Zippered Inner Divider** - Offers greater privacy between inner bedrooms. Roll away when not required
- **Sky Light Windows** - Windows which run along the roof line of the tent to increase the amount of light during the day and for star gazing at night
- **Bedroom Low Level Vents** - low level vents enhance ventilation throughout the bedrooms and decrease the chances of condensation building up



SKY BLUE  
500XL shown

### 400XL TENEDORASS0DTAR

**TOTAL WEIGHT**.....27.15kg  
**PACKED**..... 76 x 47 x 47cm  
**PITCHING TIME**..... 10 mins  
**CARTON QTY**..... 1  
**STD ORDER QTY**..... 1

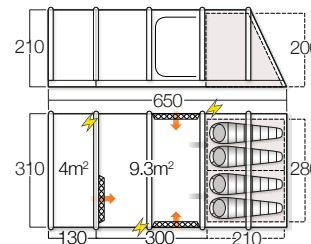

### 500XL TENEDORASS0DTAP

**TOTAL WEIGHT**.....28.30kg  
**PACKED**..... 78 x 45 x 44cm  
**PITCHING TIME**..... 10 mins  
**CARTON QTY**..... 1  
**STD ORDER QTY**..... 1

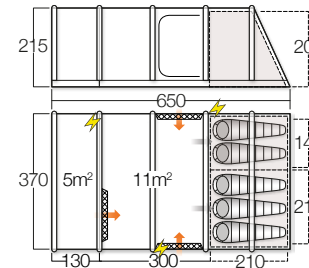

### CORE 600XL TENEDORASS0DTAQ

**TOTAL WEIGHT**.....30.40kg  
**PACKED**..... 78 x 49 x 49cm  
**PITCHING TIME**..... 10 mins  
**CARTON QTY**..... 1  
**STD ORDER QTY**..... 1

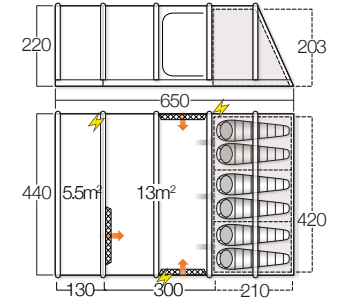

## OPTIONAL ADDITIONS



### AIRBEAM® EXCLUSIVE FRONT AWNING

400XL TANEXCLUSS0DTFK  
 500XL TANEXCLUSS0DTFL  
 600XL TANEXCLUSS0DTFM



### PORCH DOOR

400XL PDNEDORASS0DTAR  
 500XL PDNEDORASS0DTAP  
 600XL PDNEDORASS0DTAQ



### SKY SHIELD

400XL SSNEDORASS0DTAR  
 500XL SSNEDORASS0DTAP  
 600XL SSNEDORASS0DTAQ

### SKY LINER

400XL SYNEDORASS0DTAR  
 500XL SYNEDORASS0DTAP  
 600XL SYNEDORASS0DTAQ



### FITTED CARPET

400XL / 240 x 300 CPNUNIVERW11G28  
 500XL / 260 x 360 CPNUNIVERW11G29  
 600XL / 270 x 430 CPNUNIVERW11G30



### FOOTPRINT & EXTENSION G/SHEET

400XL FPNEDORASB05TAR  
 500XL FPNEDORASB05TAP  
 600XL FPNEDORASB05TAQ

# RIVENDALE 500XL UPDATED

The Rivendale is a vibrant family tent which is an ideal base for spending quality family time together and enjoying the outdoors. This tent is breathtaking in size, structure and brightness. The built-in awning is an extra living room in itself with huge vista-style windows, that will capture the best of the scenery. The Rivendale can be tailored to any family camper's needs and is sure to make any camping holiday a memorable one.

## SPECIFICATION

**PITCHING**.....Vango AirBeam® Technology  
**FLYSHEET**.....ProTex® 150D 5,000mm polyester  
**INNERS**.....Breathable polyester  
**GROUNDSHEETS**..... Fully sewn-in waterproof PE groundsheet

## FEATURES

- **Sky Track II** - A flexible hanging system which allows you to easily attach lighting, storage or our new SkyLiners. The SkyTrack system truly allows you to design your tent to suit your needs
- **Expandable Tent Bag** - An expandable tent bag with an oversized wide opening makes it simpler to pack away your tent
- **King Sized Bedrooms** - Generous king-sized bedrooms - big enough to fit a double sized airbed or double sleep mat
- **Super Zips on Flysheets Doors** - Stronger, smoother and more durable zips, ideal for the heavier weight flysheet fabric
- **Living Area Pockets** - Conveniently positioned for storing essentials
- **Zippered Inner Divider** - Offers greater privacy between inner bedrooms. Roll away when not required
- **Sky Light Windows** - Windows which run along the roof line of the tent to increase the amount of light during the day and for star gazing at night
- **Bedroom Low Level Vents** - low level vents enhance ventilation throughout the bedrooms and decrease the chances of condensation building up
- **Line-Lok® Guyline Adjusters** - Patented guyline runners. Lightweight, easy to use and will hold firm in windy conditions



SKY BLUE

TENRIVENDSODTAP

**TOTAL WEIGHT** ..... 30.20kg  
**PACKED** ..... 78 x 47 x 46cm  
**PITCHING TIME**..... 12 mins  
**CARTON QTY**..... 1

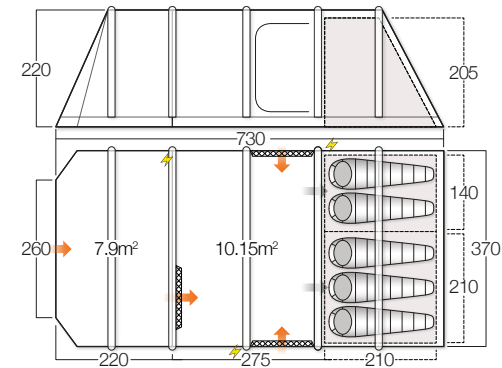

## OPTIONAL ADDITIONS



**EXCLUSIVE FRONT AWNING 500**  
TANEXLUSSODTFL



**SKY LINER**  
SYNRIVENDSODTAP



**FITTED CARPET**  
CPNUNIVERW11G29



**SKY SHIELD**  
SSNRIVENDSODTAP



**FOOTPRINT & AWNING G/SHEET**  
FPNRIVENDB05TAP

# RIVENDALE 800XL UPDATED CORE

The Rivendale is a vibrant family tent which is an ideal base for spending quality family time together and enjoying the outdoors. This tent is breathtaking in size, structure and brightness. The built-in awning is an extra living room in itself with huge vista-style windows, that will capture the best of the scenery. The Rivendale can be tailored to any family camper's needs and is sure to make any camping holiday a memorable one.

## SPECIFICATION

- PITCHING**.....Vango AirBeam® Technology  
**FLYSHEET**.....ProTex® 150D 5,000mm polyester  
**INNERS**.....Breathable polyester  
**GROUNDSHEETS**..... Fully sewn-in waterproof PE groundsheet

## FEATURES

- **Sky Track II** - A flexible hanging system which allows you to easily attach lighting, storage or our new SkyLiners. The SkyTrack system truly allows you to design your tent to suit your needs
- **Expandable Tent Bag** - An expandable tent bag with an oversized wide opening makes it simpler to pack away your tent
- **3 in 1 Bedroom** - Two zipped dividers create three separate bedrooms to sleep 6. These dividers can be removed to completely open up the inner tent into one room
- **King Sized Bedrooms** - Generous king-sized bedrooms - big enough to fit a double sized airbed or double sleep mat
- **Sky Track Bedroom** - The additional bedroom can be hung using our innovative SkyTrack® System, providing flexibility for how many people can sleep in the tent
- **Super Zips on Flysheets Doors** - Stronger, smoother and more durable zips, ideal for the heavier weight flysheet fabric
- **Living Area Pockets** - Conveniently positioned for storing essentials
- **Zipped Inner Divider** - Offers greater privacy between inner bedrooms. Roll away when not required
- **Sky Light Windows** - Windows which run along the roof line of the tent to increase the amount of light during the day and for star gazing at night
- **Bedroom Low Level Vents** - low level vents enhance ventilation throughout the bedrooms and decrease the chances of condensation building up
- **Line-Lok® Guyline Adjusters** - Patented guyline runners. Lightweight, easy to use and will hold firm in windy conditions



TENRIVENDS0DTAS

- TOTAL WEIGHT**.....33.80kg  
**PACKED**.....78 x 50 x 46cm  
**PITCHING TIME**.....12 mins  
**CARTON QTY**.....1  
**STD ORDER QTY**.....1

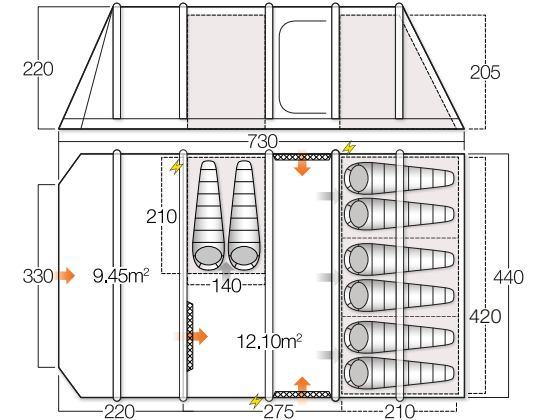

## OPTIONAL ADDITIONS



**EXCLUSIVE FRONT AWNING 600**  
TANEXCLUSS0DTFM



**SKY LINER**  
SYNRIVENDS0DTAS



**FITTED CARPET**  
CPNRIVENDW11TAS



**SKYSHIELD**  
SSNRIVENDS0DTAS



**FOOTPRINT & AWNING G/SHEET**  
FPNRIVENDB05TAS

# DIABLO 800XL UPDATED

The Vango Diablo is a name that will resonate with seasoned campers who owned this very popular poled tent. This Diablo has been re-designed using Vango AirBeam® technology, making this tent extremely easy to pitch and superior against its poled predecessor. The Diablo utilises a podded vis-a-vis tent design which maximises space and height, perfect for families seeking a versatile tent.

## SPECIFICATION

**PITCHING**.....Vango AirBeam® Technology  
**FLYSHEET**.....ProTex® 150D 5,000mm polyester  
**INNERS**.....Breathable polyester  
**GROUND SHEETS**..... Polyethylene (sewn-in) / Lightweight polyester (on inners)

## FEATURES

- **King Sized Bedrooms** - Generous king-sized bedrooms - big enough to fit a double sized airbed or double sleep mat
- **Expandable Tent Bag** - An expandable tent bag with an oversized wide opening makes it simpler to pack away your tent
- **SkyTrack® System** - Attachment system which can be used to attach lighting, tidy cables or even hang additional storage units
- **Flysheet Mesh Doors** - Secondary mesh doors on all flysheet doors - Provides ventilation whilst keeping insects outside
- **Super Zips on Flysheet Doors** - Stronger, smoother and more durable zips, ideal for the heavier weight flysheet fabric
- **Zippered Inner Divider** - Offers greater privacy between inner bedrooms. Roll away when not required
- **Sky Light Windows** - Windows which run along the roof line of the tent to increase the amount of light during the day and for star gazing at night
- **Bedroom Low Level Vents** - low level vents enhance ventilation throughout the bedrooms and decrease the chances of condensation building up
- **Line-Lok Guyline Adjusters** - Patented guyline runners. Lightweight, easy to use and will hold firm in windy conditions
- **Zippered Privacy Curtains** - Simple and quick to use, zip curtains allow varying levels of opening. Fit to the flysheet with no gaps and simply roll down into a pocket
- **Lights out inner tent** - Darker fabric reduces the amount of early morning light



SKY BLUE

**TOTAL WEIGHT**..... 41.85kg  
**PACKED**..... 78 x 50 x 48cm  
**PITCHING TIME**..... 12 mins  
**CARTON QTY**..... 1

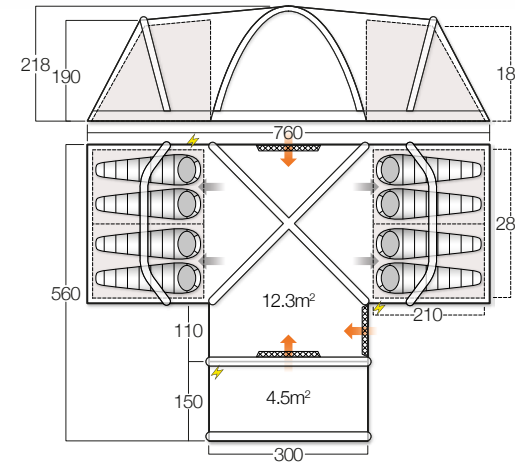

## OPTIONAL ADDITIONS



**FRONT AWNING**  
TANDIABLOS0DTHI



**SKY SHIELD**  
STD SSNDIABLOS0DTAS



**PORCH DOOR**  
PDNDIABLOS0DZ05



**FITTED CARPET**  
CPNDIABLOW11Z05



**FOOTPRINT & EXTENSION G/SHEET**  
TEMFOOTPROJQTAS

# DIABLO 1200XL UPDATED HERO

The Vango Diablo is a name that will resonate with seasoned campers who owned this very popular poled tent. This Diablo has been re-designed using Vango AirBeam® technology, making this tent extremely easy to pitch and superior against its poled predecessor. The layout includes a generous built in porch which is ideal for storage or food preparation, a large and tranquil living space and 3 king sized bedrooms.

## SPECIFICATION

- PITCHING**.....Vango AirBeam® Technology  
**FLYSHEET**.....ProTex® 150D 5,000mm polyester  
**INNERS**.....Breathable polyester  
**GROUNDSHEETS**..... Fully sewn-in waterproof PE groundsheet

## FEATURES

- **King Sized Bedrooms** - Generous king-sized bedrooms - big enough to fit a double sized airbed or double sleep mat
- **Expandable Tent Bag** - An expandable tent bag with an oversized wide opening makes it simpler to pack away your tent
- **SkyTrack® System** - Attachment system which can be used to attach lighting, tidy cables or even hang additional storage units
- **Flysheet Mesh Doors** - Secondary mesh doors on all flysheet doors - Provides ventilation whilst keeping insects outside
- **Super Zips on Flysheet Doors** - Stronger, smoother and more durable zips, ideal for the heavier weight flysheet fabric
- **Zippered Inner Divider** - Offers greater privacy between inner bedrooms. Roll away when not required
- **Sky Light Windows** - Windows which run along the roof line of the tent to increase the amount of light during the day and for star gazing at night
- **Bedroom Low Level Vents** - low level vents enhance ventilation throughout the bedrooms and decrease the chances of condensation building up
- **Zippered Privacy Curtains** - Simple and quick to use, zip curtains allow varying levels of opening. Fit to the flysheet with no gaps and simply roll down into a pocket
- **Lights out inner tent** - Darker fabric reduces the amount of early morning light



TENDIABLOS0DTEF

- TOTAL WEIGHT**..... 49.90kg  
**PACKED**..... 85 x 65 x 45cm  
**PITCHING TIME**..... 12 mins  
**CARTON QTY**..... 1  
**STD ORDER QTY**..... 1

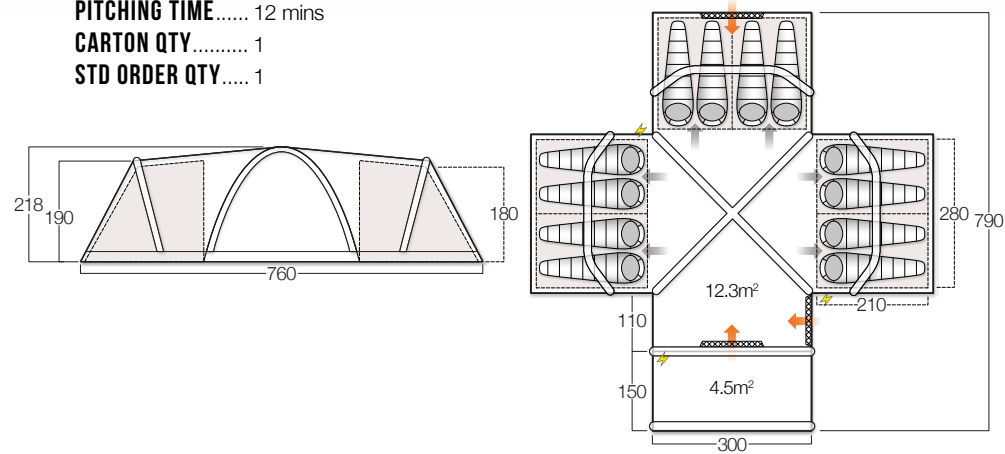

## OPTIONAL ADDITIONS



**DIABLO FRONT AWNING**  
TANDIABLOS0DTHI



**SKY SHIELD**  
SSNDIABLOS0DTEE



**PORCH DOOR**  
PDNDIABLOS0DZ05



**FITTED CARPET**  
CPNDIABLOW11Z05



**FOOTPRINT & EXTENSION G/SHEET**  
FPNDIABLOB05TEE

**AIRBEAM®**

## ELITE

The AirBeam Elite collection is the epitome of family camping, offering extreme luxury and the very best in exclusive fabrics and innovative features.

Available in a variety of sizes, ranging from 4 to 8 person tents our Elite tents have been expertly designed using either Oxford 420 Double Ripstop or our TC Polycotton. These fabrics have been selected due to their superior attributes and high quality.

To allow you to truly make the most of your outdoor home we have introduced; a range of bedroom size options, stand up head height and our new and innovative hanging system SkyTrack II®. Furthermore, we have a great range of addition such as front awnings, porch doors and our new SkyShield™ and SkyLiners™ allowing you to truly maximise the space and comfort of your new home from home.



AIRBEAM®

**ELITE**



ILLUSION 500XL



ILLUSION 800XL



MARITSA 600XL



INSPIRE 800XL



SERENITY



SOLACE TC 400



ILLUSION TC 500XL



ILLUSION TC 800XL



MARITSA TC 600XL

# ILLUSION UPDATED

The Illusion offers a beautiful balance of exquisite design and generous space. The built-in front awning creates a completely separate living area to use for food preparation, dining or storage. Alternatively, the internal wall can be rolled away to completely open up the tent creating a huge internal area. With many additional options for increasing your comfort and extending your space, it is sure to be the ultimate family tent.

## SPECIFICATION

**PITCHING**.....AirBeam® SuperBeams   
**FLYSHEET**.....ProTex® 420 double-ripstop 6,000mm polyester  
**INNERS**.....Breathable polyester  
**GROUNDSHEETS**..... Fully sewn-in Oxford polyester

## FEATURES

- **Sky Track II** - A flexible hanging system which allows you to easily attach lighting, storage or our new SkyLiners. The SkyTrack system truly allows you to design your tent to suit your needs
- **Expandable Roller Bag** - An expandable tent bag with an oversized wide opening makes it simpler to pack away your tent
- **3 in 1 Bedroom** - Two zipped dividers create three separate bedrooms to sleep 6. These dividers can be removed to completely open up the inner tent into one room (800XL only)
- **King Sized Bedrooms** - Generous king-sized bedrooms - big enough to fit a double sized airbed or double sleep mat
- **Sky Track Bedroom** - The additional bedroom can be hung using our innovative SkyTrack® System, providing flexibility for how many people can sleep in the tent (800XL only)
- **High Cable entry** - High cable entry on the internal wall allows for increased flexibility on how to feed power cables into the tent or awning
- **Flexible door step** - An adaptable door which can easily be dropped to ground level allowing you to effortlessly enter your tent without needing to step over the entrance.
- **Webbing Storm Straps** - Provides secure guying at the front and rear of the tent.
- **Vango Oversized Beams** - Larger diameter beams are used with certain shapes and fabrics, to further enhance the AirBeam experience
- **Reflective Guylines with Tidies** - Woven with a reflective strip to pick up light



HERBAL  
500XL shown

## 500XL TENILLUSIH09TAP

**TOTAL WEIGHT**..... 43.70kg  
**PACKED**..... 78 x 50 x 50cm  
**PITCHING TIME**..... 12 mins  
**CARTON QTY**..... 1

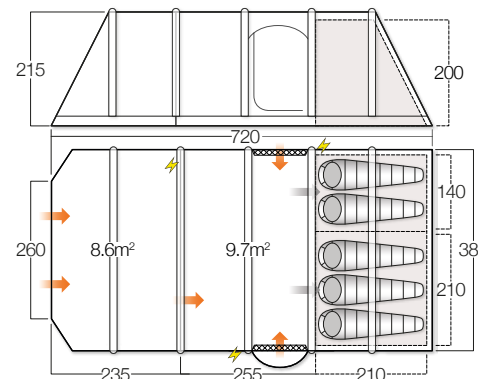

## 800XL TENILLUSIH09TAS

**TOTAL WEIGHT**..... 48.35kg  
**PACKED**..... 78 x 54 x 52cm  
**PITCHING TIME**..... 12 mins  
**CARTON QTY**..... 1

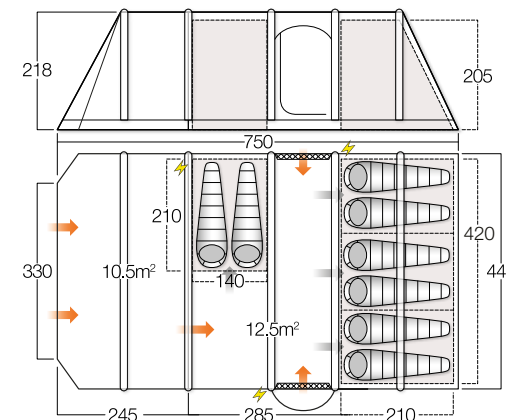

## OPTIONAL ADDITIONS



**ELITE FRONT AWNING**  
500 TANELITE H09TFL  
800 TANELITE H09TFO



**SKY LINER**  
SYNILLUSIH09TAP



**FITTED CARPET**  
500XL CPNILLUSIW11TAP  
800XL CPNILLUSIW11TAS



**SKY SHIELD**  
SSNILLUSIH09TAS



**FOOTPRINT & AWNING G/SHEET**  
500 FPNILLUSIB05TAP  
800 FPNILLUSIB05TAS



# MARITSA

UPDATED HERO

The Maritsa is perfect for family campers seeking a sophisticated tent with lots of space. Quick, easy to pitch and extremely versatile, due to its multiple entry points and abundance of living space. The layout comprises of three king-size bedrooms, two of which can be used as a walk-in wardrobe, plus a sizeable built in front awning. The high roof and large sky light windows give this tent a light and airy feel. The Maritsa will be a real head turner on the campsite and is perfect for those seeking the very best in luxurious family camping.



HERBAL

## SPECIFICATION

**PITCHING** ..... AirBeam® SuperBeams   
**FLYSHEET** ..... ProTex® 420 double-ripestop 6,000mm polyester  
**INNERS** ..... Breathable polyester  
**GROUNDSHEETS** ..... Fully sewn-in Oxford polyester

## FEATURES

- **Sky Track II** - A flexible hanging system which allows you to easily attach lighting, storage or our new SkyLiners. The SkyTrack system truly allows you to design your tent to suit your needs
- **Expandable Roller Bag** - An expandable tent bag with an oversized wide opening makes it simpler to pack away your tent
- **3 in 1 Bedroom** - Two zipped dividers create three separate bedrooms to sleep 6. These dividers can be removed to completely open up the inner tent into one room
- **Super King bedrooms** - generously increase the space within the tent inner, allowing camp beds and airbeds to fit with ease for the perfect night's sleep
- **Riser groundsheet in awning front**
- **High Cable entry** - High cable entry on the internal wall allows for increased flexibility on how to feed power cables into the tent or awning
- **Flexible door step** - An adaptable door which can easily be dropped to ground level allowing you to effortlessly enter your tent without needing to step over the entrance.
- **Webbing Storm Straps** - Provides secure guying at the front and rear of the tent.
- **Vango Oversized Beams** - Larger diameter beams are used with certain shapes and fabrics, to further enhance the AirBeam experience
- **Reflective Guylines with Tidies** - Woven with a reflective strip to pick up light
- **Wardrobe pole**

## 600XL

TENMARITSH09TAQ

**TOTAL WEIGHT** ..... 49.50kg  
**PACKED** ..... 78 x 48 x 48cm  
**PITCHING TIME** ..... 12 mins  
**CARTON QTY** ..... 1

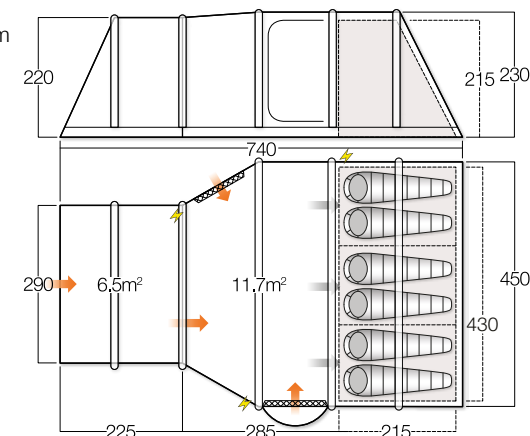

## OPTIONAL ADDITIONS



**MARITSA FRONT AWNING**  
TANMARITSH09TGB



**SKY LINER**  
SYNMARITSH09TAQ



**FITTED CARPET**  
CPNMARITSW11TAQ



**SKY SHIELD**  
SSNMARITSH09TAQ



**FOOTPRINT & AWNING G/SHEET**  
FPNMARITSB05TAQ

# INSPIRE UPDATED

Spending quality time with friends and family is what makes camping so special. This is why we have designed the Inspire to have the most generous living space of any Vango tent. Luxurious throughout, with 4 king-size bedrooms, one of which can be packed away during the day to create more space - plus the generous front extension which is ideal as an al fresco dining area. This tent is perfect for larger families on long camping breaks who look forward to catching up after a day in the outdoors.

## SPECIFICATION

**PITCHING** ..... AirBeam® SuperBeams   
**FLYSHEET** ..... ProTex® 420 double-ripstop 6,000mm polyester  
**INNERS** ..... Breathable polyester  
**GROUND SHEETS** ..... Fully sewn-in Oxford polyester

## FEATURES

- **Sky Track II** - A flexible hanging system which allows you to easily attach lighting, storage or our new SkyLiners. The SkyTrack system truly allows you to design your tent to suit your needs
- **Expandable Roller Bag** - An expandable tent bag with an oversized wide opening makes it simpler to pack away your tent
- **3 in 1 Bedroom** - Two zipped dividers create three separate bedrooms to sleep 6. These dividers can be removed to completely open up the inner tent into one room
- **King Sized Bedrooms** - Generous king-sized bedrooms - big enough to fit a double sized airbed or double sleep mat
- **Sky Track Bedroom** - The additional bedroom can be hung using our innovative SkyTrack® System, providing flexibility for how many people can sleep in the tent
- **High Cable entry** - High cable entry on the internal wall allows for increased flexibility on how to feed power cables into the tent or awning
- **Flysheet mesh doors** - Secondary mesh doors on all flysheet doors - Provides ventilation whilst keeping insects outside
- **Tent tidy** - Additional storage pod at the front of tent. Designed to store outdoor items such as toys, boots etc
- **Webbing Storm Straps** - Provides secure guying at the front and rear of the tent.
- **Vango Oversized Beams** - Larger diameter beams are used with certain shapes and fabrics, to further enhance the AirBeam experience



## 800XXL TENINSPIRH09TED

**TOTAL WEIGHT** ..... 51.50kg  
**PACKED** ..... 78 x 55 x 51 cm  
**PITCHING TIME** ..... 15 mins  
**CARTON QTY** ..... 1

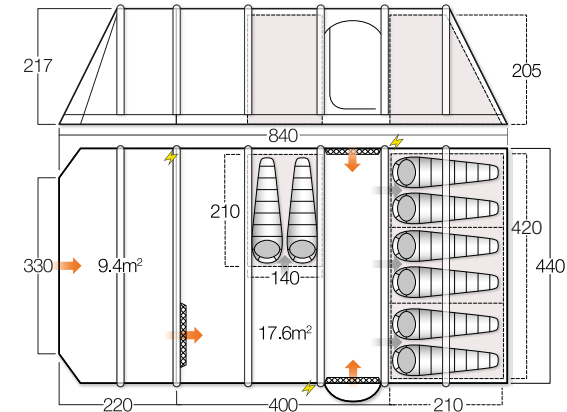

## OPTIONAL ADDITIONS



**ELITE FRONT AWNING**  
800 TANELITE H09TFO



**SUN CANOPY**  
SCNELITE H09008



**SKY LINER**  
SYNINSPIRH09TED



**FITTED CARPET**  
CPNINSPIRW11TED



**SKY SHIELD**  
SSNINSPIRH09TED



**FOOTPRINT & EXTENSION G/SHEET**  
FPNINSPIRH05TED

# SERENITY



The Serenity is produced using the highest quality materials and includes a wide range of features that really give this tent a sense of camping luxury. At the front of the Serenity is a built-in awning that provides a bright and airy conservatory space and beyond this is the fantastic living room with huge windows, Skylights, a covered entrance on one side and double doors on the other, offering a plethora of choice. To compliment the scale of the living space we have introduced the all new Emperor bedrooms which provide full stand up height throughout and lots of space for beds, storage and bedside tables. These enormous bedrooms not only feature doors from the living room, but also at the rear opening into a unique storage area.

## SPECIFICATION

**PITCHING** ..... AirBeam® SuperBeams   
**FLYSHEET** ..... ProTex® 420 double-ripstop 6,000mm polyester  
**INNERS** ..... Breathable polyester  
**GROUNDSHEETS** ..... Fully sewn-in Oxford polyester

## FEATURES

- **Sky Track II** - A flexible hanging system which allows you to easily attach lighting, storage or our new SkyLiners. The SkyTrack system truly allows you to design your tent to suit your needs
- **Expandable Roller Bag** - An expandable tent bag with an oversized wide opening makes it simpler to pack away your tent
- **3 in 1 Bedroom** - Two zipped dividers create three separate bedrooms to sleep 6. These dividers can be removed to completely open up the inner tent into one room
- **Emperor Bedrooms** - Generous king-sized bedrooms - big enough to fit a double sized airbed or double sleep mat
- **Sky Track Bedroom** - The additional bedroom can be hung using our innovative SkyTrack® System, providing flexibility for how many people can sleep in the tent
- **Flexible door step** - An adaptable door which can easily be dropped to ground level allowing you to effortlessly enter your tent without needing to step over the entrance.
- **High Cable entry** - High cable entry on the internal wall allows for increased flexibility on how to feed power cables into the tent or awning
- **Conservatory style pre-attached awning with riser groundsheet**
- **3 function doors** - entrance, window, mesh
- **Rear door for added flexibility, functionality and safety**

## OPTIONAL ADDITIONS



**SKY SHIELD**  
SSNSANTO H09173



**SKY LINER**  
SYNSERENIH09TAQ



**FITTED CARPET**  
CPNSERENIW11TAQ



**FOOTPRINT & AWNING G/SHEET**  
FPNSERENIB05TAQ



HERBAL

TENSERENIH09TAQ

**TOTAL WEIGHT** ..... 53.4kg  
**PACKED** ..... 78 x 63 x 50cm  
**PITCHING TIME** ..... 12 mins  
**CARTON QTY** ..... 1  
**STD ORDER QTY** ..... 1

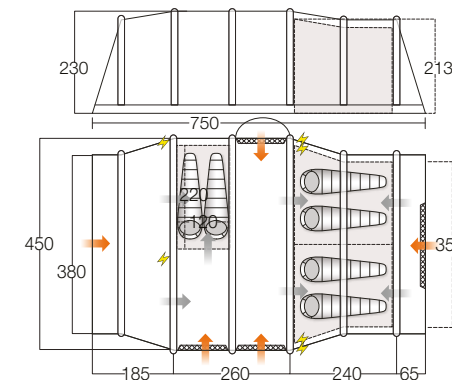

# SOLACE TC UPDATED

The Solace TC is a luxurious tent, perfect for smaller families seeking outstanding quality and impressive attention to detail. Designed using our market-leading rich polycotton flysheet the layout encompasses two king-size bedrooms, a generous living space with skylight windows and a pre-attached extension which provides cover from the sun. This tent is great for a weekend break or for a long summer holiday and is designed to the highest standard.

## SPECIFICATION

**PITCHING** ..... AirBeam® SuperBeams   
**FLYSHEET** ..... ProTex® TC polycotton 200g/m<sup>2</sup> (65% cotton/35% polyester)  
**INNERS** ..... ProTex® TC polycotton  
**GROUNDSHEETS** ..... Fully sewn-in Oxford ripstop polyester

## FEATURES

- **Sky Track II** - A flexible hanging system which allows you to easily attach lighting, storage or our new SkyLiners. The SkyTrack system truly allows you to design your tent to suit your needs
- **Expandable Roller Bag** - An expandable tent bag with an oversized wide opening makes it simpler to pack away your tent
- **King Sized Bedrooms** - Generous king-sized bedrooms - big enough to fit a double sized airbed or double sleep mat
- **Secondary mesh doors on all flysheet doors** - Provides ventilation whilst keeping insects outside
- **Webbing Storm Straps** - Provides secure guying at the front and rear of the tent.
- **Vango Oversized Beams** - Larger diameter beams are used with certain shapes and fabrics, to further enhance the AirBeam experience
- **Reflective gylines with gylines tidies** - Woven with a reflective strip to pick up light
- **Zippered inner divider** - Offers greater privacy between inner bedrooms. Roll away when not required
- **Living area pockets** - conveniently positioned pockets for storing your essentials
- **Sky Light Windows** - Windows which run along the roof line of the tent to increase the amount of light during the day and for star gazing at night



**400** TENTCSOLAN04173   
**TOTAL WEIGHT** ..... 30.50kg  
**PACKED** ..... 70 x 49 x 45cm  
**PITCHING TIME** ..... 8 mins  
**CARTON QTY** ..... 1

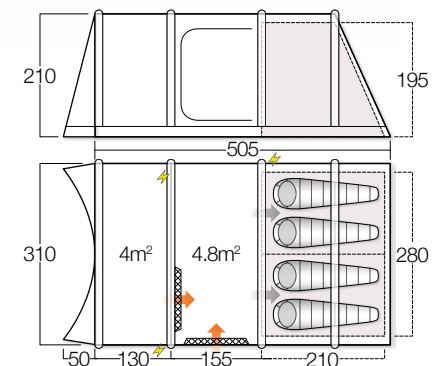

## OPTIONAL ADDITIONS



**FRONT AWNING**  
TANSOLATCH09TFK



**PORCH DOOR**  
PDNSOLATCN04173



**FITTED CARPET**  
CPNTCSOLAW11173



**UNIVERSAL CARPET**  
130 x 240 CPNUUNIVERW11G24



**FOOTPRINT & EXTENSION G/SHEET**  
FPNTCSOLAB05173

# ILLUSION TC UPDATED HERO

The Illusion offers a beautiful balance of exquisite design and generous space. The built-in front awning creates a completely separate living area to use for food preparation, dining or storage. Alternatively, the internal wall can be rolled away to completely open up the tent creating a huge internal area. With many additional options for increasing your comfort and extending your space, it is sure to be the ultimate family tent.

## SPECIFICATION

**PITCHING** ..... AirBeam® SuperBeams   
**FLYSHEET** ..... ProTex® TC polycotton 200g/m<sup>2</sup> (65% cotton/35% polyester)  
**INNERS** ..... ProTex® TC polycotton  
**GROUNDSHEETS** ..... Fully sewn-in Oxford ripstop polyester

## FEATURES

- **Sky Track II** - A flexible hanging system which allows you to easily attach lighting, storage or our new SkyLiners. The SkyTrack system truly allows you to design your tent to suit your needs
- **Expandable Roller Bag** - An expandable tent bag with an oversized wide opening makes it simpler to pack away your tent
- **3 in 1 Bedroom** - Two zipped dividers create three separate bedrooms to sleep 6. These dividers can be removed to completely open up the inner tent into one room (800XL only)
- **King Sized Bedrooms** - Generous king-sized bedrooms - big enough to fit a double sized airbed or double sleep mat
- **Riser groundsheet in awning front**
- **High Cable entry** - High cable entry on the internal wall allows for increased flexibility on how to feed power cables into the tent or awning
- **Ground Level Doors** - An adaptable door which can easily be dropped to ground level allowing you to effortlessly enter your tent without needing to step over the entrance.
- **Webbing Storm Straps** - Provides secure guying at the front and rear of the tent.
- **Vango Oversized Beams** - Larger diameter beams are used with certain shapes and fabrics, to further enhance the AirBeam experience



## 500XL TENTCILLUN04TAP

**TOTAL WEIGHT** ..... 50.55kg  
**PACKED** ..... 78 x 59 x 53cm  
**PITCHING TIME** ..... 12 mins  
**CARTON QTY** ..... 1  
**STD ORDER QTY** ..... 1

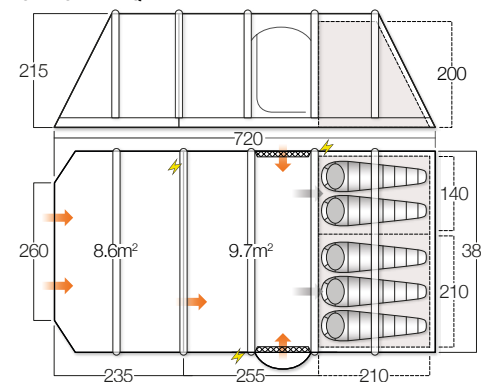

## 800XL TENTCILLUN04TAS CORE

**TOTAL WEIGHT** ..... 55kg  
**PACKED** ..... 83 x 59 x 55cm  
**PITCHING TIME** ..... 12 mins  
**CARTON QTY** ..... 1  
**STD ORDER QTY** ..... 1

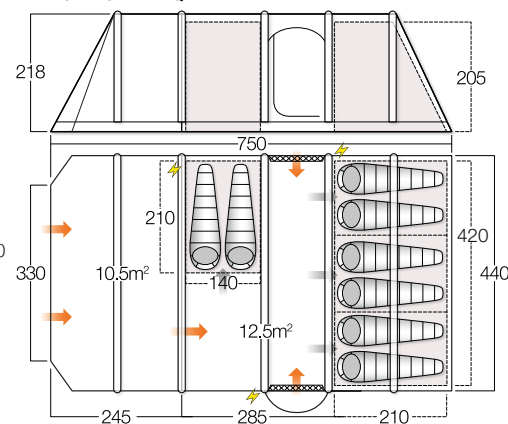

## OPTIONAL ADDITIONS



**SUN CANOPY ILLUSION TC**  
 500XL SCNTCILLUN04TAP  
 800XL SCNTCILLUN04TAS



**FITTED CARPET**  
 500XL CPNILLUSIW11TAP  
 800XL CPNILLUSIW11TAS



**FOOTPRINT & AWNING G/SHEET**  
 500 FPNILLUSIB05TAP  
 800 FPNILLUSIB05TAS

# MARITSA TC NEW

We have taken the award winning Maritsa tent and moved it to the next level by using our market leading rich Polycotton flysheet. Polycotton provides a fantastically calm environment, whilst achieving excellent protection from the elements. The Maritsa TC 600XL tent is a 6 man tent, which is perfect for family campers seeking a sophisticated tent with lots of space. It is easy to pitch and extremely versatile due to its multiple entry points and abundance of living space. A real head turner on the campsite and is perfect for those seeking the very best in luxurious family camping.

## SPECIFICATION

**PITCHING** ..... AirBeam® SuperBeams   
**FLYSHEET** ..... ProTex® TC polycotton 200g/m<sup>2</sup> (65% cotton/35% polyester)  
**INNERS** ..... ProTex® TC polycotton  
**GROUNDSHEETS** ..... Fully sewn-in Oxford ripstop polyester

## FEATURES

- **Sky Track® II** - A flexible hanging system which allows you to easily attach lighting or storage. The SkyTrack system truly allows you to design your tent to suit your needs
- **Sky Track® Bedroom** - The additional bedroom can be hung using our innovative SkyTrack® System, providing flexibility for how many people can sleep in the tent
- **Expandable Roller Bag** - An expandable tent bag with an oversized wide opening makes it simpler to pack away your tent
- **3 in 1 Bedroom** - Two zipped dividers create three separate bedrooms to sleep 6. These dividers can be removed to completely open up the inner tent into one room
- **Super King bedrooms** - generously increase the space within the tent inner, allowing camp beds and airbeds to fit with ease for the perfect night's sleep
- **Riser groundsheet in awning front**
- **High Cable entry** - High cable entry on the internal wall allows for increased flexibility on how to feed power cables into the tent or awning
- **Flexible door step** - An adaptable door which can easily be dropped to ground level allowing you to effortlessly enter your tent without needing to step over the entrance.
- **Webbing Storm Straps** - Provides secure guying at the front and rear of the tent.
- **Vango Oversized Beams** - Larger diameter beams are used with certain shapes and fabrics, to further enhance the AirBeam experience



NUTMEG

## 600XL TENTCMARIN04TAQ

**TOTAL WEIGHT** ..... 49.50kg  
**PACKED** ..... 78 x 48 x 48cm  
**PITCHING TIME** ..... 12 mins  
**CARTON QTY** ..... 1

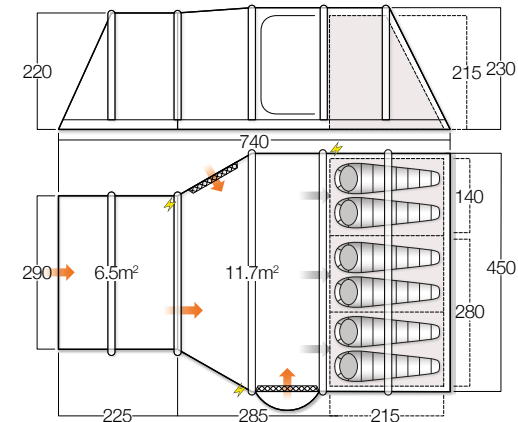

## OPTIONAL ADDITIONS



**MARITSA TC SUN CANOPY**  
TEMAWNING0DBTDP



**FITTED CARPET**  
CPNMARITSW11TAQ



**FOOTPRINT & AWNING G/SHEET**  
FPNMARITSB05TAQ

# SKY STORAGE NEW

## BASKET

The sky baskets have been designed to integrate seamlessly into any tent that has Vango's unique SkyTrack system. These handy baskets can be attached to the walls or the roof of the tent and provide additional storage space where and when its needed. Ideal for storing small items such as phones, chargers, sunglasses etc



ACNSSBASKS0Y206

## 5 POCKET

Designed to integrate seamlessly into the tent using Vango's unique SkyTrack system, this handy organiser will provide additional storage and help keep the tent tidy. It also has eyelets, for when SkyTrack is not available. Suitable for use in Vango AirBeam Exclusive and Elite tents



ACNSSORGAS0YA2G

## 8 POCKET

Designed to integrate seamlessly into the tent using Vango's unique SkyTrack system, this handy organiser will provide additional storage and help keep the tent tidy. It also has eyelets, for when SkyTrack is not available. Suitable for use in Vango AirBeam Exclusive and Elite tents



ACNSSORGAS0YA2G

## 9 POCKET

This long storage solution is designed to fit seamlessly into any tent fitted with Vango's unique SkyTrack system. It provides masses of extra space for shoes, clothing, bottles or anything else that is cluttering up the tent. Perfect for placing in front of the inner tents. Ideal for adding storage options into the Vango Excel AirBeam range, this also fits into any 2018 AirBeam model



ACNSSORGAS0YA2H

## 10 POCKET

Designed to integrate seamlessly into the tent using Vango's unique SkyTrack system, this handy organiser will provide additional storage and help keep the tent tidy. It also has eyelets, for when SkyTrack is not available. Suitable for use in Vango AirBeam Exclusive and Elite tents



ACNSSORGAS0YA2J

# TENT SPARES

## AIRBEAM® SPARES

### AIRSPEED® REPLACEMENT TUBES

Replacement inner tubes for your AirBeam® tent or awning (2015 onwards). Please refer to the AirBeam® Specification Chart on page 84 to find your correct tube size.

CARTON QTY 1



## TENT POLES

### FIBREGLASS POLE SECTION

A section of tough, durable fibreglass pole which is dependable in most weather conditions. Comes with a ferrule on one end for threading into a pole set as a replacement section.

65MM x 7.9MM ACXFIBRPO3C8P82

65MM x 8.5MM ACXFIBRPO3C9P82

65MM x 9.5MM ACXFIBRPO3D1P82

65MM x 11MM ACXFIBRPO3D2P82

65MM x 12.7MM ACXFIBRPO3D3P82

CARTON QTY 5 packs of 1 pole

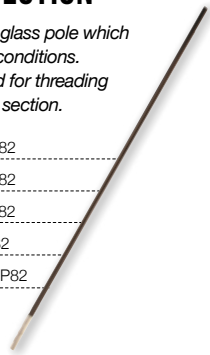

### FIBREGLASS POLE SET

These Vango Fibreglass Pole Sets are flexible yet tough and durable. Includes a spare ferrule, elastic and pole threader for easy repairs.

65MM x 7.9MM ACXFIBRPO3C8P83

65MM x 8.5MM ACXFIBRPO3C9P83

65MM x 9.5MM ACXFIBRPO3D1P83

65MM x 11MM ACXFIBRPO3D2P83

65MM x 12.7MM ACXFIBRPO3D3P83

CARTON QTY 5 packs of 5 poles



### ALLOY POLE SECTION

These Vango alloy pole sections have a very low weight to high strength ratio. Contains one section of aluminium alloy pole.

55MM x 8.5MM ACXALLOPO3D4P84

55MM x 9.5MM ACXALLOPO3D5P84

CARTON QTY 1

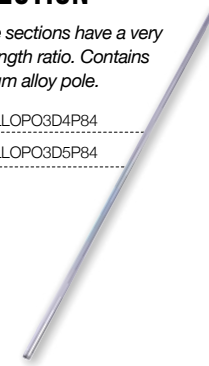

### ALLOY POLE SET

These Vango Alloy Pole Sets have a very low weight to high strength ratio. Comes with 5 sections of alloy pole, 2 pole tips and elastic.

55MM x 8.5MM ACXALLOPO3D4P85

55MM x 9.5MM ACXALLOPO3D5P85

CARTON QTY 1

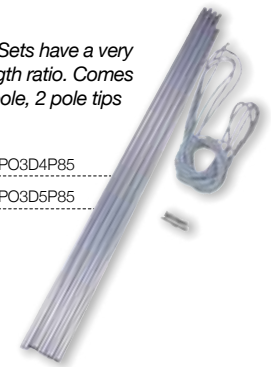

### FIBREGLASS KING POLES

ACXKINGPO3F2Z01

The Vango Fibreglass King Poles allow you to create a great porch from the front door of your adventure tent, giving you some extra shelter for cooking and generally relaxing in the outdoors. Comes with 2 poles, 2 guylines and 2 pegs.

SIZE 130cm x 2

WEIGHT 650g

CARTON QTY 5

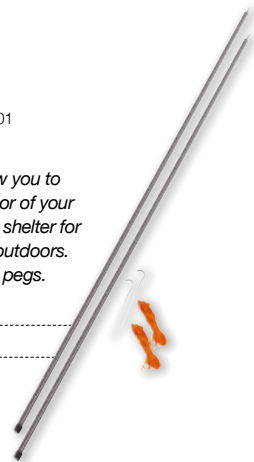

### ADJUSTABLE STEEL KING POLES

ACXKINGPO3F6Z01

The Vango Adjustable Steel King Poles allow you to create a fantastic sun canopy from the door of your tent. Comes with 2 poles, 2 guylines, 2 pegs and 2 pole caps.

SIZE 180-220cm x 2

WEIGHT 1.40kg

CARTON QTY 5

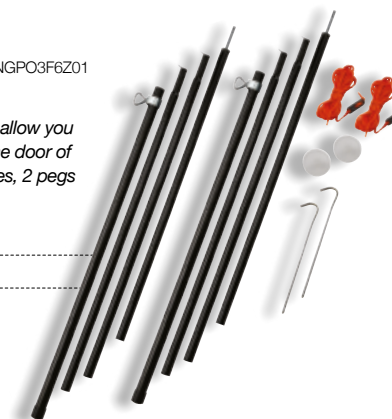



# TENT PEGS

## ALLOY CHANNEL PEGS

The shape and design of these pegs makes them excellent in varied ground conditions. They are particularly good in soft ground where pin pegs may not hold as well.

**16cm x 1cm** ACXPEGALL3B1P79  
**WEIGHT** 11g each  
**CARTON QTY** 10 packs of 5



## ALLOY PIN PEGS

Small, light and really easy to use. They will penetrate most ground conditions making them very versatile.

**18cm x 6mm** ACXPEGALL3B2P80  
**WEIGHT** 14g each  
**CARTON QTY** 10 packs of 10

**19cm x 7mm** ACXPEGALL3B3P80  
**WEIGHT** 21g each  
**CARTON QTY** 10 packs of 10



## STEEL PIN PEGS

Small, light and really easy to use. They will penetrate most ground conditions making them very versatile.

**18cm x 4mm** ACXPEGSTL3B7P80  
**WEIGHT** 19g each  
**CARTON QTY** 10 packs of 10



## STEEL V PEGS

A must have for any camping expedition. The 'V' shaped design holds securely in soft or water logged ground, whilst the rounded edges protect your guylines from breakages caused by friction.

**STANDARD 18cm** ACXPEGSTL3C4P79  
**WEIGHT** 26g each  
**CARTON QTY** 10 packs of 5

**LONG 20cm** ACXPEGSTL3C5P79  
**WEIGHT** 36g each  
**CARTON QTY** 10 packs of 5



## STEEL GROUND SHEET PEGS

Groundsheet pegs have a flattened top which won't tear a groundsheet when stood upon.

**18cm x 4mm** ACXPEGSTL3C6P79  
**WEIGHT** 26g each  
**CARTON QTY** 10 packs of 5



## ANCHOR STEEL PEG SET

New for 2018, the Vango Anchor Pegs are very strong and particularly good for hard ground. Ideal for any campsite and complete with peg extractor and hard storage case.

**23 x 20cm** PSXANCHORS04Z01  
**WEIGHT** 77g each  
**CARTON QTY** 8  
**STD ORDER QTY** 1



## BOLT PLASTIC PEG SET

New for 2018, the Vango Bolt Pegs offer extra stability in soft ground, ideal for any campsite. Comes complete with peg extractor and hard storage case.

**22 x 12cm** PSXBOLT DAVZ01  
**WEIGHT** 22g each  
**CARTON QTY** 8  
**STD ORDER QTY** 1



## GROUND BREAKER GLOW PEG SET

New for 2018, the Vango Groundbreaker Glow Pegs offer maximum strength with glow peg caps for added visibility around the campsite. These pegs can reduce the risk of trips around the campsite or at festivals. Comes complete with peg extractor and hard storage case.

**20.5cm/6.5mm X 20** PSXGROUNDY01Z01  
**WEIGHT** 58g each  
**CARTON QTY** 8  
**STD ORDER QTY** 1



# PEG EXTRACTORS & MALLETS

## 1LB STRIKE HAMMER

The Vango Strike Hammer is filled with sand so that the weight moves forwards to the head on impact, increasing the power of the strike. One piece construction for strength and durability.

**SIZE** 28.5cm  
**WEIGHT** 500g  
**CARTON QTY** 24  
**STD ORDER QTY** 1  
ACXTOOL 0BEZ01



## SUPERSTRIKE HAMMER

The Vango Super Strike Hammer is filled with sand so that the weight moves forwards to the head on impact, increasing the power of the strike. One piece construction for strength and durability.

**SIZE** 33cm  
**WEIGHT** 900g  
**CARTON QTY** 12  
**STD ORDER QTY** 1  
ACXTOOL 0BFZ01



## PEG EXTRACTOR

Extracting pegs after a camping trip can be a pain - especially in cold, wet weather when your hands are tender. This discomfort can be a thing of the past with the Vango Peg Extractor, which safely removes pegs from the ground with a comfortable handle by simply hooking on and providing an easy-to-grip lever. Packing up camp has never been so effortless.

**CARTON QTY** 120  
**STD ORDER QTY** 1  
ACXTOOL 0B7Z01



## ROUND HANDLE PEG EXTRACTOR

Extracting pegs can be a pain, especially in cold, wet weather. The Vango Peg Extractor, safely removes pegs from the ground with a comfortable round, metal handle by simply hooking on and providing an easy-to-grip lever.

**SIZE** 17 x 10cm  
**CARTON QTY** 50  
**STD ORDER QTY** 1  
ACXTOOL 0BDZ01



## LONG PEG EXTRACTOR

The Vango Long Peg Extractor makes packing up camp easier than ever before, allowing you to effortlessly hook your pegs out of the ground without straining your back or hurting your hands.

**SIZE** 60 x 8cm  
**CARTON QTY** 20  
**STD ORDER QTY** 1  
ACXTOOL 0BCZ01



# TENT PREPARATION & SERVICING

## PE GROUNDSHEET

The Vango polyethylene groundsheets provide additional protection for your tent groundsheet.

- Strong, woven polyethylene fabric
- Supplied in a durable, carry bag
- Can be folded up relatively small, allowing easy cleaning at home

**180 x 120cm** ACXGROUND0G0Z01

**WEIGHT** 300g / **CARTON QTY** 5

**200 x 200cm** ACXGROUND0G4Z01

**WEIGHT** 560g / **CARTON QTY** 5

**300 x 200cm** ACXGROUND0G5Z01

**WEIGHT** 800g / **CARTON QTY** 5

**400 x 300cm** ACXGROUND0G6Z01

**WEIGHT** 1.70kg / **CARTON QTY** 5

**600 x 400cm** ACXGROUND0G7Z01

**WEIGHT** 3.50kg / **CARTON QTY** 5



## SHOCKCORD ROLL

The Vango polyethylene groundsheets provide additional protection for your tent groundsheet.

**100m x 2.5mm** ACXSCORD3DAZ01

**CARTON QTY** 1

**100m x 5mm** ACXSCORD3DCZ01

**CARTON QTY** 1



## PEG ELASTIC (x4)

A 4 pack of elastics, ideal for replacing worn out pegging points.

**15cm x 5mm** ACXPEGELA3D9P86

**CARTON QTY** 10

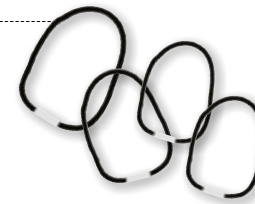

## FIBREGLASS SERVICE PACK

The Vango fibreglass service pack contains every element you could need when fixing your tent.

- 6 x 65cm x 7.9mm fibreglass poles
- 6 x 65cm x 8.5mm fibreglass poles
- 6 x 65cm x 9.5mm fibreglass poles
- 12 x 65cm x 11mm fibreglass poles
- 12 x 65cm x 12.7mm fibreglass poles
- 2 x 500cm shockcord
- 2 x steel ferrules
- 2 x steel ring & pin
- 1 x shockcord threader

**CARTON QTY** 1

ACXRETAIL3D8Z01



## ADVENTURE/TREK GUYLINES

A 2 pack of 300cm gylines with runners, coloured orange to match your adventure or trekking tents.

**300cm x 2** ACXGUYLINO07TEB

**CARTON QTY** 10



## FAMILY GUYLINES

A 2 pack of 500cm gylines with runners, coloured yellow to match your family tents.

**500cm x 2** ACXGUYLINO01P30

**CARTON QTY** 10



## ELITE GUYLINES

A 2 pack of 500cm reflective gylines with runners coloured brown to match your Elite family tents.

**500cm x 2** ACKGUYLINB16GL5

**CARTON QTY** 10





## VANGO AWNINGS

*Our collection of AirBeam® Awnings are created to the highest standard with unique, exclusive features, with a model and design to ensuring each model and design boast a home from home feel.*

*For 2018, we have continued to evolve and innovate our AirAway® drive away awnings and AirAwning® caravan awnings to guarantee premium quality and bring our customers unrivalled luxury and technology. Integration of our registered SkyTrack® system enhances the potential for fixtures and fittings to reach a new level and provides a renewed system compared to traditional restrictive hanging loops.*

*Our design team have introduced a lighter and brighter atmosphere in our versatile collection of AirAway awnings with the addition of Sky Lights, radiating light throughout the living area when privacy is required and the curtains are closed. Reshaped beams result in increased head room and a brighter ambience in our AirAwning® collection.*

*Our industry leading awnings offer multiple fitting options to ensure they are compatible with a wide range of caravans, motorhomes and campervans to meet the needs of consumers.*



Pitched in a matter of minutes, our collection of drive away awnings for campervans and motorhomes.



Extend your living space with our quick pitch inflatable caravan awnings

# VANGO AIRAWAY® - DRIVEAWAY AWNINGS

See the Vango Awning collection workbook for full product information



## IDRIS II LOW / TALL

- Sentinel Active 70 • Linked-in groundsheet
- Vango AirZone • Fully zipped mesh door
- Dropdown groundsheet at front door

**WEIGHT** ..... 14.25kg / 14.65kg  
**PACK SIZE** ..... 70 x 31 x 31cm / 70 x 33 x 33cm



## KELA IV CORE LOW / STD / TALL

- Sentinel Pro 420 • Fully sewn-in Oxford groundsheet
- Vango AirZone • Fully zipped mesh doors
- Webbing storm straps • Zipped privacy curtains

**WEIGHT** ..... 17.25kg / 17.35kg / 17.5kg  
**PACK SIZE** ..... 78 x 37 x 35cm / 78 x 37 x 35cm  
 / 78 x 37 x 36cm



## CRUZ II LOW / TALL

- Sentinel Pro 420 • Fully sewn-in Oxford groundsheet
- Vango AirZone • Pre-bend SuperBeams
- Webbing storm straps • Zipped privacy curtains

**WEIGHT** ..... 21.6kg / 22.15kg  
**PACK SIZE** ..... 78 x 47 x 37cm / 78 x 47 x 415cm



## GALLI COMPACT HERO LOW / TALL / RSV LOW / TALL

- Sentinel Pro 420 • Fully sewn-in Oxford groundsheet
- Vango AirZone • Pre-bend SuperBeams
- Webbing storm straps • Zipped privacy curtains

**WEIGHT** ..... 21.9kg / 22.2kg / 21.9kg / 22.2kg  
**PACK SIZE** ..... 74 x 39 x 36cm / 78 x 41 x 37cm  
 / 74 x 39 x 36cm / 78 x 41 x 37cm



## GALLI II HERO LOW / TALL / RSV LOW / TALL

- Sentinel Pro 420 • Fully sewn-in Oxford groundsheet
- Vango AirZone • Pre-bend SuperBeams
- Webbing storm straps • Zipped privacy curtains

**WEIGHT** ..... 26.6kg / 27.2kg / 26.6kg / 27.2kg  
**PACK SIZE** ..... 78 x 42 x 40cm / 78 x 44 x 42cm  
 / 78 x 42 x 40cm / 78 x 44 x 42cm



## AIRAWAY HUB HEX LOW / TALL

- Sentinel Pro 420 • Linked in groundsheet
- Vango AirZone • Webbing storm straps
- Zipped privacy curtains

**WEIGHT** ..... 20.35kg / 20.55kg  
**PACK SIZE** ..... 70 x 42 x 40cm / 70 x 43 x 42cm

# VANGO AIRAWAY® - CARAVAN AWNINGS

See the Vango Awning collection workbook for full product information



## RAPIDE II

250 / 350 / 400

- Sentinel Comfort 150 Fabric • Oversized AirBeams®
- Vango AirZone • Zipped privacy curtains
- Diamond Clear Windows

**WEIGHT** ..... 15.8kg / 17.2kg / 18.5kg

**PACK SIZE** ..... 78 x 34 x 34cm / 78 x 38 x 35cm  
/ 78 x 42 x 38cm



## BRAEMAR II

300 / 400

- Sentinel Comfort 150 Fabric • AirSpeed Valves
- Flexi doors & side door entry • Zipped privacy curtains
- Diamond Clear Windows

**WEIGHT** ..... 21.9kg / 26.2kg

**PACK SIZE** ..... 78 x 46 x 39cm / 78 x 46 x 41cm



## SONOMA II

250 / 350 / 400

- Sentinel Pro 420 • AirSpeed Valves
- Oversized AirBeams® • Flexi doors & side door entry
- Zipped privacy curtains • Diamond Clear Windows

**WEIGHT** ..... 21.6kg / 23.9kg / 24.5kg

**PACK SIZE** ..... 78 x 40 x 36cm / 78 x 42 x 37cm  
/ 78 x 43 x 38cm



## VARKALA III

CORE

280 / 360 / 420 / 520

- Sentinel Pro 420 • AirSpeed Valves
- Flexi doors & side door entry • Zipped privacy curtains
- Diamond Clear Windows

**WEIGHT** ..... 23.5kg / 25kg / 27.2kg

**PACK SIZE** ..... 78 x 40 x 40cm / 78 x 42 x 41cm  
/ 78 x 43 x 41cm



## VARKALA CONNECT

HERO

280 / 360 / 420 / 520

- Sentinel Pro 420 • AirSpeed Valves
- Flexi doors & side door entry • Zipped privacy curtains
- Diamond Clear Windows • Removable panel for extension

**WEIGHT** ..... 24.3kg / 25kg / 28.25kg / 34.5kg

**PACK SIZE** ..... 78 x 42 x 40cm / 78 x 44 x 39cm  
/ 78 x 47 x 42cm / 78 x 48 x 47cm



## KALARI II

HERO

380 / 420 / 520

- Sentinel Luxe 600 • AirSpeed Valves
- Pre-bend SuperBeams • Flexi doors & side door entry
- Zipped privacy curtains • Diamond Clear Windows

**WEIGHT** ..... 31.6kg / 34.25kg / 38.9kg

**PACK SIZE** ..... 78 x 46 x 45cm / 78 x 46 x 45cm  
/ 78 x 48 x 48cm



## SLEEPING BAGS

*Performance, comfort and aesthetics are critical to creating sleeping bags that meet consumers needs and so, this has once again been our focus for 2018.*

*Our team have been busy creating some fantastic design led colourways and styles for a modern and fresh take on our Family sleeping bag range. From perfectly balanced Fiesta Brights to Nature Loving Neutrals, our range will look at home whatever your camping style and needs.*

*The much-loved Adventure range is back for 2018 with upgraded fabrics and smart new colours including Bondi Blue and Baton Rouge which will make you want to get out with your friends and enjoy the outdoors in style.*

*On the technical side, our sleeping bags reflect our passion for innovation and technology with all of our technical down bags having moved to Hydro-Barrier Down in 2017. The comprehensive range gives a collection of bags with varying warmth to weight ratios that will suit any adventure in the wild.*

*With the environment and animal welfare being a major priority in our manufacturing process we ensure that all of the down used in our sleeping bag filling is ethically sourced throughout our supply chain and traceable back to its point of origin so you can sleep tight in the knowledge that no animals were harmed in the making of our bags.*

*The innovative new designs and user orientated updates mean our range of Family, Adventure and Technical sleeping bags are all set for your next adventure whatever that may be.*

### FAMILY

Keeping you warm and cosy on your family adventures

### ADVENTURE

The perfect selection for first timers, festival goers and youth group adventurers

### TECHNICAL

The ultimate bags for outdoor enthusiasts and experts, implementing the most advanced technologies



## FAMILY SLEEPING BAGS

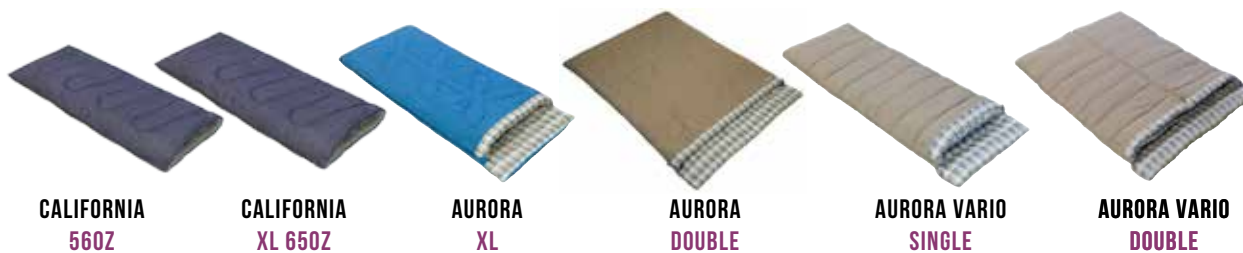



# EMBER NEW

Part of the Vango Experience collection, these fantastic value square-shaped sleeping bag come in a range of stunning colours. The Ember is a 2 season bag constructed using quality fabrics and fills, combined with a small price tag, making it the ideal purchase for cost-conscious family campers and festival goers.

- Integrated head rest
- Single-layer stitch through construction
- Polair® Shell - 190T Polyester Cired
- Single hole hollow fibre insulation
- S-Stitching
- Two-way auto-lock zip
- Temperature ratings independently measured in accordance with EN 13537:2012
- Hanging loops
- Colour co-ordinated stuff sack with drawcord

## SINGLE HERO

COMFORT	8°C
LOWER LIMIT	4°C
EXTREME	-10°C

**Suggested Usage:** 8 to 20°C

**Performance:** 2 season

**TOG:** 8

**Dimensions:** 200 x 75 x 75cm

**Max user height:** 190cm

**Weight:** 1.25kg

**Fill weight:** 1 x 250g/m<sup>2</sup>

**Packed:** 37 x Ø21cm

**Carton qty:** 6

**Order qty:** 6



**HOT CORAL**  
SBNEMBERH30TJ8



**JADE LIME**  
SBNEMBER J36TJ8

**BATON ROUGE**  
SBNEMBER B35TJ8

**BONDI BLUE**  
SBNEMBER B36TJ8

**BLACK**  
SBNEMBER B05TJ8

## SINGLE LUX

COMFORT	6°C
LOWER LIMIT	1°C
EXTREME	-14°C

**Suggested Usage:** 6 to 20°C

**Performance:** 3 season

**TOG:** 9.5

**Dimensions:** 200 x 75 x 75cm

**Max user height:** 190cm

**Weight:** 1.55kg

**Fill weight:** 1 x 350g/m<sup>2</sup>

**Packed:** 41 x Ø22cm

**Carton qty:** 6

**Order qty:** 6



**HOT CORAL**  
SBNEMBLUXH30TJ8

**BLACK**  
SBNEMBLUXB05TJ8

## DOUBLE

COMFORT	9°C
LOWER LIMIT	5°C
EXTREME	-8°C

**Suggested Usage:** 9 to 20°C

**Performance:** 2 season

**TOG:** 7.5

**Dimensions:** 210 x 150 x 150cm

**Max user height:** 190cm

**Weight:** 2.5kg

**Fill weight:** 1 x 250g/m<sup>2</sup>

**Packed:** 53 x Ø32cm

**Carton qty:** 4

**Order qty:** 4



**BONDI BLUE**  
SBNEMBER B36S68

**BATON ROUGE**  
SBNEMBER B35S68

# HARMONY UPDATED

This 2 season square bag is extremely functional and has a comfortable tog rating of 8, so perfect for use in the summer. It features a one-layer construction which combines a plush microfibre polyester shell and brushed polyester lining for superior comfort. The Harmony is perfect for first-time campers or families.

- Square shaped bag
- Single-layer stitch through construction
- 100% polyester 190T slightly brushed lining
- 210T Microfibre Polyester shell
- Single hole siliconised hollow fibre insulation
- Horizontal stitching
- Integrated head rest
- Woven zip puller
- Zip guard with anti-catch piping
- Insulated zip baffle
- Hanging loops
- Internal pocket
- Temperature ratings independently measured in accordance with EN 13537:2002
- 4-strap compression stuffsack

## SINGLE CORE



**Suggested Usage:** 8 to 20°C  
**Performance:** 2 season  
**TOG:** 8  
**Dimensions:** 215 x 50 x 80cm  
**Max user height:** 190cm  
**Weight:** 1.6kg  
**Fill weight:** 1 x 250g/m<sup>2</sup>  
**Packed:** 40 x Ø23cm  
**Carton qty:** 6  
**Order qty:** 6



**SKY BLUE**  
SBNHARMONS0DTJ8

**JADE LIME**  
SBNHARMONJ36TJ8

**BLACK**  
SBNHARMONB05TJ8

**NUTMEG**  
SBNHARMONN04TJ8

## XL



**Suggested Usage:** 8 to 20°C  
**Performance:** 2 season  
**TOG:** 8  
**Dimensions:** 225 x 100 x 100cm  
**Max user height:** 190cm  
**Weight:** 2.1kg  
**Fill weight:** 1 x 250g/m<sup>2</sup>  
**Packed:** 43 x Ø28cm  
**Carton qty:** 6  
**Order qty:** 6



**BLACK**  
SBNHARMONB05S08

## DOUBLE CORE

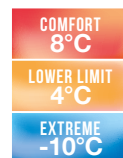

**Suggested Usage:** 8 to 20°C  
**Performance:** 2 season  
**TOG:** 8  
**Dimensions:** 215 x 150 x 150cm  
**Max user height:** 190cm  
**Weight:** 3.6kg  
**Fill weight:** 1 x 350g/m<sup>2</sup>  
**Packed:** 58 x Ø31cm  
**Carton qty:** 6  
**Order qty:** 6



**NUTMEG**  
SBNHARMONN04S68

**SKY BLUE**  
SBNHARMONS0DS68

# HARMONY DELUXE NEW HERO

Based on the award winning Vango Serenity, the Harmony Deluxe provides outstanding performance along with incredible comfort. This is a 3 season bag, which has a tog rating of 10 - perfect for Spring through to Autumn use. A square-shaped bag, the Harmony Deluxe offers double layer insulation for extra comfort and warmth as well as a distinctive geometric print and soft-touch lining. The Harmony bag gives a home-from-home feel people want in their tent or caravan.

- Square shape carry bag
- Integrated head rest
- Square sleeping bag
- Off-set double layer construction
- Insulated zip baffle
- 100% polyester 190T slightly brushed lining
- 210T Microfibre Polyester shell
- Single hole siliconised hollow fibre insulation
- Internal pocket
- Horizontal stitching
- Woven zip puller
- Zip guard with anti-catch piping
- Hanging loops

## SINGLE

COMFORT	2°C
LOWER LIMIT	-3°C
EXTREME	-20°C

**Suggested Usage:** -1 to 18°C

**Performance:** 3 season

**TOG:** 10

**Dimensions:** 215 x 80 x 80cm

**Max user height:** 190cm

**Weight:** 2.28kg

**Fill weight:** 2 x 200g/m<sup>2</sup>

**Packed:** 42 x 18 x 45cm

**Carton qty:** 4

**Order qty:** 4



**NUTMEG**  
SBNHARDLXN04TJ8

## XL

COMFORT	2°C
LOWER LIMIT	-3°C
EXTREME	-20°C

**Suggested Usage:** -1 to 18°C

**Performance:** 3 season

**TOG:** 10

**Dimensions:** 225 x 100 x 100cm

**Max user height:** 190cm

**Weight:** 3.04kg

**Fill weight:** 2 x 200g/m<sup>2</sup>

**Packed:** 50 x 20 x 45cm

**Carton qty:** 4

**Order qty:** 4



**BLACK**  
SBNHARDLXB05S08

## DOUBLE

COMFORT	2°C
LOWER LIMIT	-3°C
EXTREME	-20°C

**Suggested Usage:** -1 to 18°C

**Performance:** 3 season

**TOG:** 10

**Dimensions:** 215 x 150 x 150cm

**Max user height:** 190cm

**Weight:** 4.24kg

**Fill weight:** 2 x 200g/m<sup>2</sup>

**Packed:** 55 x 25 x 50cm

**Carton qty:** 2

**Order qty:** 2



**SKY BLUE**  
SBNHARDLXS0DS68



**Layers separate to make 2 singles**  
on double bag

# CALIFORNIA NEW

These spacious duvet style square sleeping bags have been developed for camping, caravans and campervans. The California bags come in a 56oz or XL 65oz, the xl being wider and longer. Both are constructed with a high quality hollow fibre fill and a cotton soft touch polyester lining. These bags have been cleverly designed to zip two of the same sizes together in order to create one large double size sleeping bag. Its contemporary design will complement any home away from home and, with Vango's experience in outdoor gear design, it will provide a warm and comfortable nights sleep.

- Single-layer stitch through construction
- Innovative fabric lining offers a cotton touch feel, with the benefits of polyester
- 100% printed polyester shell fabric is comfortable, soft to touch and durable.
- Re-useable, zipped, clear PVC carry bag
- Single hole hollow fibre insulation
- S-Stitching
- Two-way auto-lock zip
- Temperature ratings independently measured
- Hanging loops - Hang bag to air

## 56oz

COMFORT	9°C
LOWER LIMIT	5°C
EXTREME	-8°C

**Suggested Usage:** 9 to 20°C

**Performance:** 2 season

**TOG:** 7.5

**Dimensions:** 193 x 83 x 83cm

**Max user height:** 190cm

**Weight:** 1.77kg

**Fill weight:** 1 x 300g/m<sup>2</sup>

**Packed:** 45 x 18 x 44cm

**Carton qty:** 4

**Order qty:** 4



GREY TEXTURE  
SBNCALIFOG10S56



2 singles join together to make a double



## XL 65oz HERO

COMFORT	9°C
LOWER LIMIT	5°C
EXTREME	-8°C

**Suggested Usage:** 9 to 20°C

**Performance:** 2 season

**TOG:** 7.5

**Dimensions:** 203 x 92 x 92cm

**Max user height:** 190cm

**Weight:** 2.02kg

**Fill weight:** 1 x 300g/m<sup>2</sup>

**Packed:** 45 x 22 x 45cm

**Carton qty:** 4

**Order qty:** 4



GREY TEXTURE  
SBNCALIFOG10S47

# AURORA

A firm favorite with campers, the Aurora is a 3 season sleeping bag with a superior double layer construction. It's 100% cotton flannel lining and polycotton shell radiates luxury. It is the perfect bag for anyone looking for a home from home feel. With its sophisticated checked pattern you are sure to enjoy a night under the stars with the Aurora. This bag is perfect from campers and caravanners alike and comes with two complementary pillow cases for that extra bit of comfort.

The XL, as the name suggests, is ideally suited to those who are looking for a little extra space and the double is perfect for two!

- Quilted stitching
- 100% printed cotton flannel 230g/m<sup>2</sup> lining
- Square shape carry bag
- Polycotton shell - Soft to touch, comfortable and durable fabric. 30% Cotton/70% Polyester 150g/m
- Square shaped bag
- Comfortable cotton flannel pillowcase included with sleeping bag - 1 with double
- Off-set double layer construction
- Single hole siliconised hollow fibre insulation
- Integrated head rest
- Woven zip puller
- Two-way auto-lock zip
- Double can be converted into two singles

## Polycotton shell

Soft to touch, comfortable and durable fabric

## Pillowcase

Double comes with 2

**XL** CORE



**Suggested Usage:** -1 to 18°C

**Performance:** 3 season

**TOG:** 10

**Dimensions:** 235 x 105 x 105cm

**Max user height:** 210cm

**Weight:** 1.25kg

**Fill weight:** 2 x 175g/m<sup>2</sup>

**Packed:** 44 x 23 x 48cm

**Carton qty:** 4

**Order qty:** 4



**DOUBLE** CORE



**Suggested Usage:** -1 to 18°C

**Performance:** 3 season

**TOG:** 10

**Dimensions:** 225 x 170 x 170cm

**Max user height:** 200cm

**Weight:** 6.15kg

**Fill weight:** 2 x 175g/m<sup>2</sup>

**Packed:** 50 x 25 x 59cm

**Carton qty:** 2

**Order qty:** 2



# AURORA VARIO NEW XL

The Aurora Vario has been designed to convert from a 3 season to 2 season sleeping bag by simply zipping one layer away, perfect for space conscious campers. The sleeping bag also features a vibrant lining print and combines luxurious soft to touch fabrics with a superior brushed polyester shell. The Vario is a versatile sleeping bag that is ideal for those who want to regulate their temperature and is ideal for camping, caravans, motor homes or simply sleep overs at home

- Square shaped sleeping bag
- Square shaped carry bag
- Integrated head rest
- Top layer zips off/folds under - adjustable warmth
- Off-set double layer construction
- Insulated zip baffle
- 210T, 100% Microfibre Polyester lining
- 220T, 100% Microfibre Polyester with a peached finish shell
- Single hole siliconised hollow fibre insulation
- Internal pocket
- Horizontal stitching
- Woven zip puller
- Two-way auto-lock zip
- Zip guard with anti-catch piping

COMFORT	4°C
LOWER LIMIT	-1°C
EXTREME	-16°C

**Suggested Usage:** 1 to 20°C

**Performance:** 2-3 season

**TOG:** 9

**Dimensions:** 215 x 80 x 80cm

**Max user height:** 190cm

**Weight:** 2.63kg

**Fill weight:** Top & Middle 250g/m<sup>2</sup> - Bottom 300g/m<sup>2</sup>

**Packed:** 40 x 20 x 25cm

**Carton qty:** 4

**Order qty:** 4



**NUTMEG**  
SBNAURVARN04TJ8

## DOUBLE

COMFORT	4°C
LOWER LIMIT	-1°C
EXTREME	-16°C

**Suggested Usage:** 1 to 20°C

**Performance:** 2 - 3 season

**TOG:** 9

**Dimensions:** 215 x 150 x 150cm

**Max user height:** 190cm

**Weight:** 4.73kg

**Fill weight:** Top & Middle 250g/m<sup>2</sup> - Bottom 300g/m<sup>2</sup>

**Packed:** 50 x 25 x 59cm

**Carton qty:** 2

**Order qty:** 2



**NUTMEG**  
SBNAURVARN04S68

**Removable top layer**  
for warmer weather





## ADVENTURE SLEEPING BAGS



# ATLAS UPDATED

Combining great quality with exceptional value, the Atlas sleeping bag is perfect for festival goers and those taking their first steps into the world of camping. This mummy-shaped bag boasts a unique S-stitched pattern to hold the insulating fibre in place, while the 8.5 TOG rating guarantees a comfortable nights' sleep.

- Single-layer stitch through construction
- Polair® Shell - 190T Polyester Cired
- Single hole hollow fibre insulation
- S-Stitching - Holds the insulating fibre in place
- Mummy-shaped sleeping bag
- Shaped hood with drawcord closure (not junior)
- Two-way auto-lock zip
- Hanging loops - Hang bag to air
- Colour co-ordinated stuff sack with drawcord
- New 250 Square shape offers extra freedom at the bottom of the bag
- Elasticated hood (junior)

**250** CORE

COMFORT  
7°C  
LOWER LIMIT  
2°C  
EXTREME  
-13°C

**Suggested Usage:** 7 to 20°C  
**Performance:** 2 season  
**TOG:** 8.5  
**Dimensions:** 210 x 80 x 50cm  
**Max user height:** 185cm  
**Weight:** 1.25kg  
**Fill weight:** 1 x 250g/m<sup>2</sup>  
**Packed:** 42 x Ø21cm  
**Carton qty:** 6  
**Order qty:** 6

BLACK  
SBNATLAS B05163

BATON ROUGE  
SBNATLAS B35163

JADE LIME  
SBNATLAS J36163

BONDI BLUE  
SBNATLAS B36163

**250 SQUARE**

COMFORT  
6°C  
LOWER LIMIT  
1°C  
EXTREME  
-14°C

**Suggested Usage:** 6 to 20°C  
**Performance:** 3 season  
**TOG:** 8.5  
**Dimensions:** 210 x 80 x 80cm  
**Max user height:** 190cm  
**Weight:** 1.42kg  
**Fill weight:** 1 x 125g/m<sup>2</sup>  
**Packed:** 42 x 23cm  
**Carton qty:** 6  
**Order qty:** 6

BLACK  
SBNATLAS B05S42

HOT CORAL  
SBNATLAS H30S42

**350** CORE

COMFORT  
2°C  
LOWER LIMIT  
-3°C  
EXTREME  
-20°C

**Suggested Usage:** 0 to 20°C  
**Performance:** 3 season  
**TOG:** 9.5  
**Dimensions:** 210 x 80 x 50cm  
**Max user height:** 185cm  
**Weight:** 1.55kg  
**Fill weight:** 1 x 350g/m<sup>2</sup>  
**Packed:** 42 x Ø26cm  
**Carton qty:** 6  
**Order qty:** 6

BONDI BLUE  
SBNATLAS B36172

**JUNIOR** CORE

**Suggested Usage:** 10 to 20°C  
**Performance:** 2 season  
**TOG:** 8.5  
**Dimensions:** 150 x 66 x 45cm  
**Max user height:** 145cm  
**Weight:** 950g  
**Fill weight:** 1 x 250g/m<sup>2</sup>  
**Packed:** 37 x Ø21cm  
**Carton qty:** 6  
**Order qty:** 6

BATON ROUGE  
SBNATLAS B35S51

BONDI BLUE  
SBNATLAS B36S51



# WILDERNESS UPDATED



Vibrant colours, soft touch fabrics and simple design combine to create our Wilderness 250 sleeping bag. This fantastic value bag is ideal for family campers and festival goers alike. Recommended for use by The Scout Association.

- Single-layer stitch through construction
- 100% polyester 190T slightly brushed lining
- 210T Microfibre Polyester shell
- Single hole siliconised hollow fibre insulation
- Internal pocket
- Horizontal stitching
- Mummy-shaped sleeping bag
- Woven zip puller
- Two-way auto-lock zip
- Zip guard with anti-catch piping
- Insulated zip & shoulder baffle
- Hanging loops
- 4-strap compression stuffsack - Minimises pack size

## 250 CORE

COMFORT 5°C
LOWER LIMIT 0°C
EXTREME -15°C

**Suggested Usage:** 3 to 20°C

**Performance:** 2-3 season

**TOG:** 9

**Dimensions:** 215 x 80 x 50cm

**Max user height:** 190cm

**Weight:** 1.5kg

**Fill weight:** 1 x 250g/m<sup>2</sup>

**Packed:** 41 x Ø21cm

**Carton qty:** 6

**Order qty:** 6



**HOT CORAL**  
SBNWILDERH30163



**COBALT BLUE**  
SBNWILDERC17163

## 250S

COMFORT 5°C
LOWER LIMIT 0°C
EXTREME -15°C

**Suggested Usage:** 3 to 20°C

**Performance:** 2-3 season

**TOG:** 9

**Dimensions:** 200 x 80 x 50cm

**Max user height:** 175cm

**Weight:** 1.4kg

**Fill weight:** 1 x 250g/m<sup>2</sup>

**Packed:** 40 x Ø19cm

**Carton qty:** 6

**Order qty:** 6



**BONDI BLUE**  
SBNWILDERB36S7F

## 350 CORE

COMFORT 3°C
LOWER LIMIT -2°C
EXTREME -18°C

**Suggested Usage:** 1 to 20°C

**Performance:** 3 season

**TOG:** 9.5

**Dimensions:** 215 x 80 x 50cm

**Max user height:** 190cm

**Weight:** 1.85kg

**Fill weight:** 1 x 350g/m<sup>2</sup>

**Packed:** 42 x Ø26cm

**Carton qty:** 6

**Order qty:** 6



**JADE LIME**  
SBNWILDERJ36172



**BLACK**  
SBNWILDERB05172

## JUNIOR CORE

**Suggested Usage:** 8 to 20°C

**Performance:** 2 season

**TOG:** 9

**Dimensions:** 160 x 70 x 50cm

**Max user height:** 150cm

**Weight:** 1.1kg

**Fill weight:** 1 x 250g/m<sup>2</sup>

**Packed:** 36 x Ø21cm

**Carton qty:** 6

**Order qty:** 6



**COBALT BLUE**  
SBNWILDERC17S51



**HOT CORAL**  
SBNWILDERH30S51



**FROG**  
SBNWILDERF29S51



**PENGUIN**  
SBNWILDERROIS51

# NITESTAR UPDATED



Featuring vibrant colours and offering a winning combination of performance and quality, the mummy-shaped Nitestar sleeping bag delivers excellent value. Offering embossed polyester and a double layer of insulation for extra warmth, the 4 season Nitestar is an ideal choice for Youth Groups and first time expedition use.

- Off-set double layer construction
- 210T Diamond Embossed Polyester
- 100% polyester 190T brushed
- Single hole siliconised hollow fibre insulation
- Internal pocket
- Horizontal stitching
- Mummy-shaped sleeping bag (except 'quad' bags)
- Woven zip puller
- Two-way auto-lock zip
- Zip guard with anti-catch piping
- Hanging loops
- 4-strap compression stuffsack
- Temperature ratings independently measured

## 300 QUAD

COMFORT	1°C
LOWER LIMIT	-5°C
EXTREME	-22°C

**Suggested Usage:** -2 to 18°C  
**Performance:** 3 season  
**TOG:** 10  
**Dimensions:** 210 x 80 x 80cm  
**Max user height:** 190cm  
**Weight:** 2kg  
**Fill weight:** 2 x 150g/m<sup>2</sup>  
**Packed:** 33 x Ø27cm  
**Carton qty:** 6  
**Order qty:** 6



EXCALIBUR  
SBNNITESTE27S3U

## 250

COMFORT	2°C
LOWER LIMIT	-3°C
EXTREME	-19°C

**Suggested Usage:** -1 to 20°C  
**Performance:** 3 season  
**TOG:** 10  
**Dimensions:** 215 x 85 x 50cm  
**Max user height:** 190cm  
**Weight:** 1.65kg  
**Fill weight:** 2 x 125g/m<sup>2</sup>  
**Packed:** 30 x Ø22cm  
**Carton qty:** 6  
**Order qty:** 6



EXCALIBUR  
SBNNITESTE27163

COBALT  
SBNNITESTC17163

CORE

## 250S

COMFORT	2°C
LOWER LIMIT	-3°C
EXTREME	-19°C

**Suggested Usage:** -1 to 20°C  
**Performance:** 3t season  
**TOG:** 10  
**Dimensions:** 190 x 75 x 75cm  
**Max user height:** 190cm  
**Weight:** 1.25kg  
**Fill weight:** 1 x 250g/m<sup>2</sup>  
**Packed:** 31 x Ø22cm  
**Carton qty:** 6  
**Order qty:** 6



BATON ROUGE  
SBNNITESTB35S7F

## 350

COMFORT	0°C
LOWER LIMIT	-6°C
EXTREME	-24°C

**Suggested Usage:** -2 to 18°C  
**Performance:** 3-4 season  
**TOG:** 10.5  
**Dimensions:** 215 x 85 x 50cm  
**Max user height:** 190cm  
**Weight:** 2kg  
**Fill weight:** 2 x 175g/m<sup>2</sup>  
**Packed:** 35 x Ø24cm  
**Carton qty:** 6  
**Order qty:** 6



EXCALIBUR  
SBNNITESTE27172

BONDI BLUE  
SBNNITESTB36172



## 450

COMFORT	-2°C
LOWER LIMIT	-8°C
EXTREME	-26°C

**Suggested Usage:** -8 to 15°C  
**Performance:** 4 season  
**TOG:** 11  
**Dimensions:** 215 x 85 x 50cm  
**Max user height:** 190cm  
**Weight:** 2.3kg  
**Fill weight:** 2 x 225g/m<sup>2</sup>  
**Packed:** 36 x Ø27cm  
**Carton qty:** 6  
**Order qty:** 6



RED  
SBNNITESTR03176

COBALT  
SBNNITESTC17H05



## JUNIOR

**Suggested Usage:** 8 to 20°C  
**Performance:** 2 season  
**TOG:** 8  
**Dimensions:** 190 x 75 x 75cm  
**Max user height:** 190cm  
**Weight:** 1.25kg  
**Fill weight:** 1 x 250g/m<sup>2</sup>  
**Packed:** 29 x Ø21cm  
**Carton qty:** 6  
**Order qty:** 6



BATON ROUGE  
SBNNITESTB35H05



## TECHNICAL SLEEPING BAGS

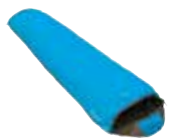

PLANET  
50



PLANET  
100



PLANET  
150



LATITUDE  
200



LATITUDE  
300 REG / LONG



LATITUDE  
400



LATITUDE  
200 QUAD



LATITUDE  
300 QUAD



ULTRALITE PRO  
100



ULTRALITE PRO  
200 REG / LONG



ULTRALITE PRO  
300



VENOM  
200



VENOM  
300



VENOM  
400



VENOM  
600



F10 VULCAN  
-7°



F10 VULCAN  
-12°



F10 VULCAN  
-17°

# PLANET UPDATED

Our award-winning Planet sleeping bag is back for 2018! Designed for long distance travellers, the Planet is lightweight with a small pack size. Vango Shield protects the bag against bacteria, mould and insects, while our treated mosquito net at the head and foot keep out unwanted bugs. The fleece lined stuff sack reverses to form a pillow for a comfortable night's sleep whatever your environment.

- Insulite™ Superfine insulation - a blend of spiralsised, siliconised fibres, make a highly compressible, extremely durable and lightweight filling
- Loose shell - Reduces cold spots to keep you warmer at night
- Diamond polyester ripstop shell
- Soft to the touch, Polair Silky gives a huge level of comfort
- Lightweight mosquito net - with an anti-bacterial finish
- Vango Shield - effectively repels insects and prevents growth of bacteria
- 2 panel 3D hood - prevents heat loss from the head
- Zip extends around foot - optional ventilation at the foot of bag
- Full length two-way auto-lock zip with zip guard
- Insulated zip baffle - retains heat within the bag and reduces cold spots
- Internal pocket - convenient storage for small items
- Reversible stuffsack is fleece lined and can be used to create a pillow.
- Temperature ratings independently measured
- Part of the Vango Planet Series travel range



WINNER

INDUSTRY  
AWARD 2015



## 50

COMFORT	11°C
LOWER LIMIT	7°C
EXTREME	-6°C

**Suggested Usage:** 11 to 25°C  
**Performance:** 1-2 season  
**Dimensions:** 210 x 80 x 55cm  
**Max user height:** 190cm  
**Weight:** 900g  
**Fill weight:** 1 x 50g/m<sup>2</sup>  
**Packed:** 22 x Ø15cm  
**Carton qty:** 6  
**Order qty:** 6

VOLT BLUE  
SBNPLANETV20063



## 150

COMFORT	6°C
LOWER LIMIT	1°C
EXTREME	-14°C

**Suggested Usage:** 4 to 20°C  
**Performance:** 2-3 season  
**Dimensions:** 210 x 80 x 55cm  
**Max user height:** 190cm  
**Weight:** 1.3kg  
**Fill weight:** 1 x 150g/m<sup>2</sup>  
**Packed:** 25 x Ø20cm  
**Carton qty:** 6  
**Order qty:** 6

VOLT BLUE  
SBNPLANETA07111



## 100 CORE

COMFORT	8°C
LOWER LIMIT	4°C
EXTREME	-10°C

**Suggested Usage:** 8 to 25°C  
**Performance:** 2 season  
**TOG:** 8  
**Dimensions:** 210 x 80 x 55cm  
**Max user height:** 190cm  
**Weight:** 1.1kg  
**Fill weight:** 1 x 100g/m<sup>2</sup>  
**Packed:** 37 x Ø21cm  
**Carton qty:** 6  
**Order qty:** 6

VOLCANO  
SBNPLANETV17077



# LATITUDE



The Latitude is ideal for those on adventure trips and expeditions in need of a dependable sleeping bag. The Vango Thermal Embrace System increases the effectiveness of the sleeping bag's insulation while the Thermal-Reverb reflects heat back to the user. Insulite™ Helix insulation uses a mix of hollow and multi-channel fibres, which wicks moisture, regulates temperature and provides effective insulation, perfect for the campsite or wild camping expeditions.

- Off-set double layer construction
- Insulite™ Helix
- Polair Experience diamond ripstop polyester
- Soft to the touch, Polair Silky gives a level of comfort that is hugely beneficial after a long day's trekking
- Thermal-Reverb
- Thermal Embrace System
- Insulated, adjustable shoulder baffle
- 3D hood with multi-cord closure
- Arrow Foot (except 'quad' bags)
- Insulated zip baffle
- Full length two-way auto-lock zip with zip guard
- Internal pocket
- 4-strap compression stuffsack
- Temperature ratings independently measured

## 200 CORE

COMFORT	2°C
LOWER LIMIT	-3°C
EXTREME	-20°C

**Suggested Usage:** -3 to 20°C  
**Performance:** 3 season  
**Dimensions:** 210 x 80 x 50cm  
**Max user height:** 190cm  
**Weight:** 1.5kg  
**Fill weight:** 2 x 100g/m<sup>2</sup>  
**Packed:** 25 x Ø22cm  
**Carton qty:** 6  
**Order qty:** 6

**VOLCANO**  
 SBMLATTIUV17151



## 300 CORE

COMFORT	-1°C
LOWER LIMIT	-7°C
EXTREME	-25°C

**Suggested Usage:** -7 to 20°C  
**Performance:** 3-4 season  
**Dimensions:** 210 x 80 x 50cm  
**Max user height:** 190cm  
**Weight:** 1.8kg  
**Fill weight:** 2 x 150g/m<sup>2</sup>  
**Packed:** 29 x Ø24cm  
**Carton qty:** 6  
**Order qty:** 6

**IMPERIAL BLUE**  
 SBMLATTIUI23165



## 300 LONG

COMFORT	-1°C
LOWER LIMIT	-7°C
EXTREME	-25°C

**Suggested Usage:** -7 to 20°C  
**Performance:** 3-4 season  
**Dimensions:** 225 x 82 x 52cm  
**Max user height:** 205cm  
**Weight:** 2.1kg  
**Fill weight:** 2 x 150g/m<sup>2</sup>  
**Packed:** 32 x Ø25cm  
**Carton qty:** 6  
**Order qty:** 6

**IMPERIAL BLUE**  
 SBMLATTIUI23S3T



## 400 CORE

COMFORT	-4°C
LOWER LIMIT	-11°C
EXTREME	-30°C

**Suggested Usage:** -11 to 15°C  
**Performance:** 4 season  
**Dimensions:** 210 x 80 x 50cm  
**Max user height:** 190cm  
**Weight:** 2.1kg  
**Fill weight:** 2 x 200g/m<sup>2</sup>  
**Packed:** 32 x Ø26cm  
**Carton qty:** 6  
**Order qty:** 6

**GRASSHOPPER**  
 SBMLATTIUG18173



## 200 SUPERQUAD HERO

COMFORT	2°C
LOWER LIMIT	-3°C
EXTREME	-20°C

**Suggested Usage:** -3 to 20°C  
**Performance:** 3 season  
**Dimensions:** 220 x 95 x 95cm  
**Max user height:** 200cm  
**Weight:** 2.3kg  
**Fill weight:** 2 x 100g/m<sup>2</sup>  
**Packed:** 34 x Ø27cm  
**Carton qty:** 6  
**Order qty:** 6

**VOLCANO**  
 SBMLATTIUV17S48



## 300 QUAD HERO

COMFORT	-1°C
LOWER LIMIT	-7°C
EXTREME	-25°C

**Suggested Usage:** -7 to 20°C  
**Performance:** 3-4 season  
**Dimensions:** 210 x 80 x 80cm  
**Max user height:** 190cm  
**Weight:** 2.3kg  
**Fill weight:** 2 x 150g/m<sup>2</sup>  
**Packed:** 34 x Ø27cm  
**Carton qty:** 6  
**Order qty:** 6

**IMPERIAL BLUE**  
 SBMLATTIUI23S3U



# ULTRALITE PRO



The Vango Ultralite Pro sleeping bag is designed for year-round explorers who demand low weight and small pack size. The wicking 4T synthetic insulation - structured in a Trilateral construction - improves warmth, eliminates cold spots and conforms closer to the body. Thermal-Reverb redirects heat radiated from the body back to the user making the bag warmer. The Ultralite Pro was made for trekking, guaranteeing a comfortable, warm night's sleep regardless of the outside temperature.

- Trilateral construction.
- Polair® Active shell and lining.
- 4T synthetic insulation.
- Thermal Embrace System.
- Omega shaping.
- Arrow foot.
- 3D hood with multi-cord closure.
- Insulated shoulder and zip baffles.
- Two-way auto-lock zip with zip guard.
- Internal pocket.
- 4-strap compression stuffsack.
- Temperature ratings independently measured. in Accordance with EN 13537:2012.

## TRI-LATERAL CONSTRUCTION

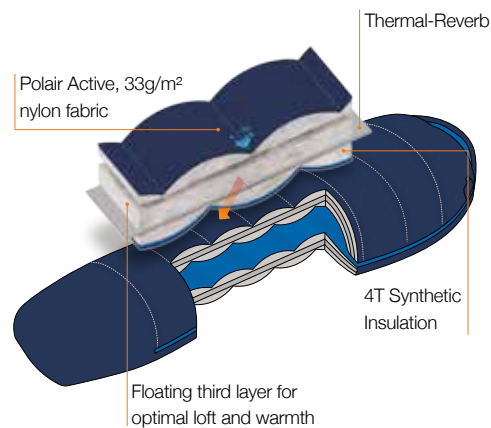

HERO

100 CORE

COMFORT 8°C  
LOWER LIMIT 4°C  
EXTREME -10°C

**Suggested Usage:** 4 to 25°C  
**Performance:** 2 season  
**Dimensions:** 210 x 80 x 50cm  
**Max user height:** 190cm  
**Weight:** 900g  
**Fill weight:** 100g/m<sup>2</sup>  
**Packed:** 24 x Ø18cm  
**Carton qty:** 4  
**Order qty:** 4



PAPRIKA  
SBMULTRA P13077

200 CORE

COMFORT 8°C  
LOWER LIMIT 4°C  
EXTREME -10°C

**Suggested Usage:** -1 to 20°C  
**Performance:** 3 season  
**Dimensions:** 210 x 80 x 50cm  
**Max user height:** 190cm  
**Weight:** 1.10kg  
**Fill weight:** 170g/m<sup>2</sup>  
**Packed:** 25 x Ø22cm  
**Carton qty:** 4  
**Order qty:** 4



COBALT  
SBMULTRA C17151



COBALT  
SBMULTRA C17229

200 LONG NEW

COMFORT 4°C  
LOWER LIMIT -1°C  
EXTREME -16°C

**Suggested Usage:** -1 to 20°C  
**Performance:** 3 season  
**Dimensions:** 225 x 82 x 52cm  
**Max user height:** 205cm  
**Weight:** 1.25kg  
**Fill weight:** 170g/m<sup>2</sup>  
**Packed:** 26 x Ø23cm  
**Carton qty:** 4  
**Order qty:** 4

300 CORE

COMFORT 8°C  
LOWER LIMIT 4°C  
EXTREME -10°C

**Suggested Usage:** -6 to 15°C  
**Performance:** 3-4 season  
**Dimensions:** 210 x 80 x 50cm  
**Max user height:** 190cm  
**Weight:** 1.35  
**Fill weight:** 260g/m<sup>2</sup>  
**Packed:** 27 x Ø24cm  
**Carton qty:** 4  
**Order qty:** 4



ANTHRACITE  
SBMULTRA A07165

# VENOM



The popular Venom sleeping bag features hydrophobic down with a high performing 700 fill power, ideal for both wet and dry conditions. This Sleeping Bag is ideal for those seeking maximum warmth with minimal weight and pack size for year round adventure. Recommended by The Duke of Edinburgh's Award and The Scouts Association.

- Box wall construction.
- Polair® Ascent shell and lining.
- Hydro-Barrier Down insulation.
- Ethically sourced down.
- Omega shaping.
- Arrow foot.
- 3D hood with multi-cord closure.
- Insulated shoulder and zip baffles.
- Two-way auto-lock zip with zip guard.
- Internal pocket.
- Roll-top drybag stuffsack.
- Mesh storage bag.
- Temperature ratings independently measured. in Accordance with EN 13537:2012.



## 200

COMFORT 9°C
LOWER LIMIT 5°C
EXTREME -9°C

**Suggested Usage:** 5 to 25°C  
**Performance:** 2 season  
**Dimensions:** 210 x 80 x 50cm  
**Max user height:** 190cm  
**Weight:** 700g  
**Fill weight:** 200g  
**Packed:** 27 x Ø13cm  
**Carton qty:** 4  
**Order qty:** 4



VOLCANO  
SBMVENOMV17151

## 300

COMFORT 5°C
LOWER LIMIT 0°C
EXTREME -15°C

**Suggested Usage:** 0 to 20°C  
**Performance:** 2-3 season  
**Dimensions:** 210 x 80 x 50cm  
**Max user height:** 190cm  
**Weight:** 900g  
**Fill weight:** 300g  
**Packed:** 29 x Ø14cm  
**Carton qty:** 4  
**Order qty:** 4



IMPERIAL BLUE  
SBMVENOMI23165

## 400

COMFORT 2°C
LOWER LIMIT -4°C
EXTREME -20°C

**Suggested Usage:** -4 to 20°C  
**Performance:** 3 season  
**Dimensions:** 210 x 80 x 50cm  
**Max user height:** 190cm  
**Weight:** 1.00kg  
**Fill weight:** 400g  
**Packed:** 30 x Ø15cm  
**Carton qty:** 4  
**Order qty:** 4



VERMILLION  
SBMVENOMV16173

## 600

COMFORT -3°C
LOWER LIMIT -10°C
EXTREME -28°C

**Suggested Usage:** -10 to 15°C  
**Performance:** 4 season  
**Dimensions:** 210 x 80 x 50cm  
**Max user height:** 190cm  
**Weight:** 1.25kg  
**Fill weight:** 600g  
**Packed:** 30 x Ø19cm  
**Carton qty:** 4  
**Order qty:** 4



GRASSHOPPER  
SBMVENOMG18181

**Roll top drybag**  
sealed, water tight bag



# F10 VULCAN

The F10 Vulcan is the logical home for outdoor enthusiasts and experts. Featuring Hydro Barrier Down in a reflective V-baffle construction, all wrapped in lightweight, soft 20D nylon fabrics to ensure a sound night's sleep in warmth and comfort. The ethically sourced down attains a great warmth to weight ratio. This results in a low comfort temperature rating coupled with low weight, ideal for pushing the limits of minimum gear, maximum adventure!

- V-Baffle construction
  - Polair® Enduro shell.
  - Hydro-Barrier Down insulation.
  - Ethically sourced down.
  - Polair® Active lining.
  - Omega shaping.
  - Arrow foot.
  - 3D hood with multi-cord closure.
  - Insulated 3D shoulder baffle.
  - Two-way auto-lock zip with zip guard.
  - Interlocking zip baffles.
  - Zipped internal pocket.
  - Roll-top drybag stuffsack.
  - Mesh storage bag.
  - Temperature ratings independently measured.
- in Accordance with EN 13537:2012.



-7°

COMFORT	-1°C
LOWER LIMIT	-7°C
EXTREME	-24°C

**SUGGESTED USAGE:** -7 to 24°C  
**PERFORMANCE:** 3 season  
**DIMENSIONS:** 220 x 80 x 50cm  
**MAX USER HEIGHT:** 200cm  
**WEIGHT:** 1.00kg  
**FILL WEIGHT:** 400g  
**PACKED:** 29 x Ø20cm  
**ORDER QTY:** 1



LAVA  
SBMVULCANL0ASE9

-12°

COMFORT	-5°C
LOWER LIMIT	-12°C
EXTREME	-32°C

**SUGGESTED USAGE:** -12 to 15°C  
**PERFORMANCE:** 4 season  
**DIMENSIONS:** 220 x 80 x 50cm  
**MAX USER HEIGHT:** 200cm  
**WEIGHT:** 1.25kg  
**FILL WEIGHT:** 650g  
**PACKED:** 30 x Ø22cm  
**ORDER QTY:** 1



LAVA  
SBMVULCANL0ASE7

## V-BAFFLE CONSTRUCTION

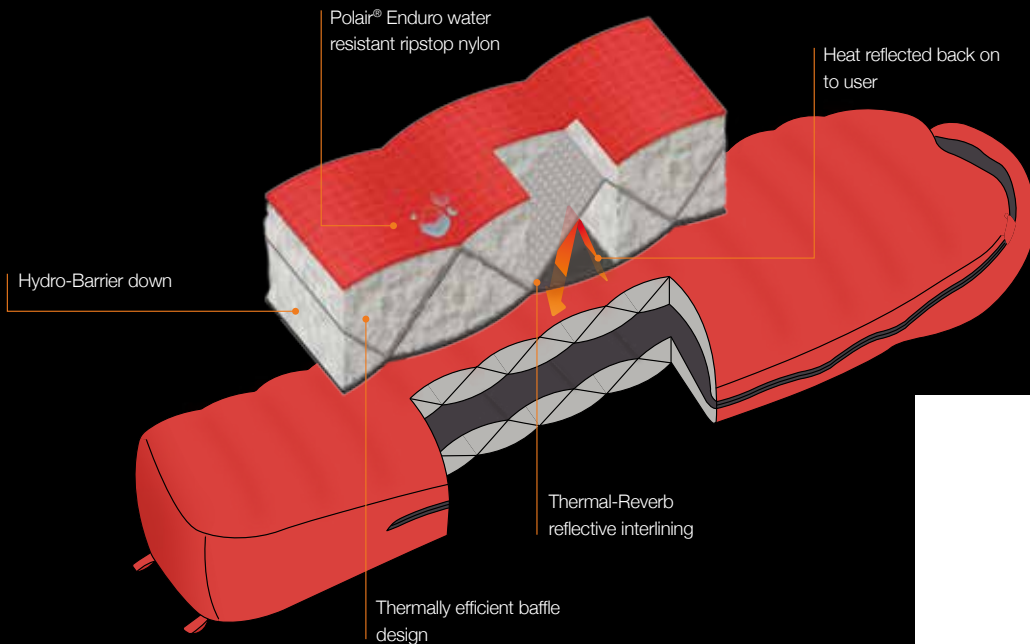

-17°

COMFORT	-9°C
LOWER LIMIT	-17°C
EXTREME	-38°C

**SUGGESTED USAGE:** -17 to 10°C  
**PERFORMANCE:** 5 season  
**DIMENSIONS:** 220 x 80 x 50cm  
**MAX USER HEIGHT:** 200cm  
**WEIGHT:** 1.55kg  
**FILL WEIGHT:** 900g  
**PACKED:** 33 x Ø24cm  
**ORDER QTY:** 1



LAVA  
SBMVULCANL0ASE0





## SLEEP MATS

*We understand the importance of a good night's sleep after a busy day in the great outdoors, and know that a comfortable mat can make all the difference in helping you to slip into a deep sleep under the stars.*

*Over the past year, we have put a lot of research and development into our 2018 collection, this year we are launching not only new mat's but also innovative technology. Our deluxe Shangri-La mat is our thickest mat to date and more of a camping mattress due to its 15cm vertical wall construction, which adds to the mats comfort and warmth. The Shangri-La features our new Cyclone-Valve system making it super easy to inflate and more importantly pack away.*

*Our range of trek mats have been updated with our new Fast-Flow valve and now features a non-slip print which landscapes the contours of Bein Nevis. From our ultralight to super comfy, Vango sleeping mats will guarantee a great night's sleep.*

# FAMILY SLEEP MATS

## DREAMER

Part of the Vango Experience collection, the Dreamer self inflating sleep mat will provide a high level of comfort with its insulated filling and soft touch durable fabric cover. The simple twist valve makes getting ready for a night under the stars quick and easy and when ready to pack up, the Dreamer is compact and lightweight. Designed to marry perfectly with sleeping bags in the Experience collection (like the superb Ember) the Dreamer is the ideal companion for a great nights sleep.

### 3CM

#### SINGLE

SIZE..... L183 x W51 x H3cm  
PACKED.....55 x Ø12cm  
WEIGHT ..... 1.2kg  
TOG RATING..... 7  
CARTON QTY..... 6  
STD ORDER QTY. 6



BONDI BLUE  
SMNDREAMEB36A14

#### DOUBLE

SIZE..... L183X x W128 x H3cm  
PACKED......66 x Ø19cm  
WEIGHT ..... 3.06kg  
TOG RATING..... 7  
CARTON QTY.....2  
STD ORDER QTY. 2



BONDI BLUE  
SMNDREAMEB36A06

### 5CM

#### SINGLE

SIZE..... L183 x W63 x H5cm  
PACKED......63 x Ø15cm  
WEIGHT ..... 1.6kg  
TOG RATING..... 10  
CARTON QTY..... 6  
STD ORDER QTY. 6



TREETOPS  
SMNDREAMET15A11

#### DOUBLE

SIZE..... L183 x W128 x H5cm  
PACKED......66 x Ø22cm  
WEIGHT ..... 3.6kg  
TOG RATING..... 10  
CARTON QTY.....2  
STD ORDER QTY. 2



TREETOPS  
SMNDREAMET15A02

# COMFORT UPDATED

The luxurious Comfort range of self-inflating sleeping mats offers unrivalled comfort and convenience, featuring up to 10cm of optimised insulation with a stylish, soft-touch flocked finish on the top-side and a durable non-slip base. The Comfort now includes the new Cyclone Flip Valve, making inflation and deflation much quicker and easier than traditional valves. Simply flip open the valve and watch the mat expand. Prefer a firmer mattress? Then simply top it up with a few extra puffs of air. After a great night's sleep, the Cyclone valve's very large opening means the air evacuates quickly making packing away a cinch.

- The robust polyester base fabric won't slip on your inner tent's floor.
- Cyclone flip valve - new reversible valve allows airflow in or out, without flowing back; ensures the quickest inflation and pack away times
- Brushed fabric on top surface is comfortable and warm to touch
- 5-10cm insulating foam - Exceptionally comfortable and warm
- Carry bag constructed from soft fabric to allow use as pillow.
- Carry bag and securing straps included
- Repair kit included
- Materials meet and exceed the European REACH standard

## 5

### SINGLE

SIZE ..... L200 x W60 x H5cm  
 PACKED ..... 62 x Ø17cm  
 WEIGHT ..... 1.95kg  
 TOG RATING ..... 10  
 CARTON QTY ..... 6  
 STD ORDER QTY. 6

BONDI BLUE  
 SMNCOMFORB36A11



### DOUBLE

SIZE ..... L200 x W130 x H5cm  
 PACKED ..... 66 x Ø21cm  
 WEIGHT ..... 4.4kg  
 TOG RATING ..... 10  
 CARTON QTY ..... 2  
 STD ORDER QTY. 2

BONDI BLUE  
 SMNCOMFORB36A02



## 7.5

### SINGLE

SIZE ..... L200 x D60x H7.5cm  
 PACKED ..... 64 x Ø20cm  
 WEIGHT ..... 2.66kg  
 TOG RATING ..... 13  
 CARTON QTY ..... 4  
 STD ORDER QTY. 4

HERBAL  
 SMNCOMFORH09A12



### GRANDE

SIZE ..... L200 x W76 x H7.5cm  
 PACKED ..... 77 x Ø20cm  
 WEIGHT ..... 3.7kg  
 TOG RATING ..... 13  
 CARTON QTY ..... 4  
 STD ORDER QTY. 4

HERBAL  
 SMNCOMFORH09M1K



### DOUBLE

CORE

SIZE ..... L200 x D130 x H7.5cm  
 PACKED ..... 68 x Ø32cm  
 WEIGHT ..... 5.47kg  
 TOG RATING ..... 13  
 CARTON QTY ..... 2  
 STD ORDER QTY. 2

HERBAL  
 SMNCOMFORH09A05



10

**SINGLE**

SIZE..... L200 x W60 x H10cm  
PACKED.....63 x Ø28m  
WEIGHT .....3kg  
TOG RATING..... 16  
CARTON QTY..... 4  
STD ORDER QTY. 4



NUTMEG  
SMNCOMFORN04A13

**GRANDE**

SIZE..... L200 x W76 x H10cm  
PACKED.....80 x Ø22cm  
WEIGHT .....3.86kg  
TOG RATING..... 16  
CARTON QTY..... 4  
STD ORDER QTY. 4



NUTMEG  
SMNCOMFORN04RU5

**DOUBLE**



SIZE..... L200 x WD130 x H10cm  
PACKED.....67 x Ø35cm  
WEIGHT .....6.65kg  
TOG RATING..... 16  
CARTON QTY..... 2  
STD ORDER QTY. 2



NUTMEG  
SMNCOMFORN04A09

# AIRBEAM CLOUD NEW HERO

Get that sense of floating on air with the Cloud camping mattress. This is a top of the range sleep system that is designed to combine the comfort and insulation of a mattress from home with the convenience of a super small packed size, that won't take up precious space in the car boot. The soft touch fabric is incredibly strong and contained inside is our ThermoCore insulation that will keep you protected from the cold ground, making this so much more than a sleep mat.

- Cloud Cord Loop - Cords connect the upper and lower sections of the mattress giving a stable and 'sprung' platform for sleeping on
- Elastic Fabric - Produced using a soft, elastic yarn knitted into a comfortable fabric providing a home-from-home feeling with the best possible night's sleep
- Ultra-Reliable - Produced using precision machined products, high end TPU lamination and strong fabrics ensuring that you won't be let down by your mattress
- TPU Lamination - Modern TPU fabric lamination is lighter and allows for smaller pack than traditional PVC, also allowing the mat to pack away quicker and smaller
- Vertical Walls - The Mattress is three dimensionally constructed with vertical walls so all upper surface is usable providing a bigger surface area and more comfortable sleep
- Thermocore - Synthetic Fibre insulation, bonded to the upper face of the mattress to insulate against the cold ground ensuring a warm comfortable sleep
- Compatible with Vango AirBeam Pumps

## 12CM

### GRANDE

LENGTH.....	210cm
WIDTH.....	85cm
HEIGHT.....	12cm
PACKED.....	.31 x Ø18cm
WEIGHT.....	1.6kg
TOG RATING.....	7
CARTON QTY.....	4
STD ORDER QTY.	4



SKY BLUE  
SMNCLLOUD S0DM1L

## DOUBLE

LENGTH.....	210cm
WIDTH.....	120cm
HEIGHT.....	12cm
PACKED.....	.31 x Ø21cm
WEIGHT.....	2.16kg
TOG RATING.....	7
CARTON QTY.....	4
STD ORDER QTY.	4



SKY BLUE  
SMNCLLOUD S0DA00

The Shangri-La, as the name suggests, is the pinnacle of Vango's self inflating mat collection. Indeed, this is more than a mat, it is a self inflating mattress, designed to provide all the comfort of your bed at home with the convenience of a small packsize. The mattress comes in a wide mouthed carry bag, making it easy to get in and out and when you're ready for bed, simply open up the easy to use Cyclone valve and watch the bed unfold in front of you

- **Cyclone Valve** - Allowing fast and easy inflation and deflation
- **Elastic Fabric** - Produced using a soft, elastic yarn knitted into a comfortable fabric providing a home-from-home feeling with the best possible night's sleep.
- **Ultra-Reliable** - Produced using precision machined products, high end TPU lamination and strong fabrics ensuring that you won't be let down by your mattress.
- **TPU Lamination** - Modern TPU fabric lamination is lighter and allows for smaller pack than traditional PVC, also allowing the mat to pack away quicker and smaller.
- **Vertical Walls** - The Mattress is three dimensionally constructed with vertical walls so all upper surface is usable providing a bigger surface area and more comfortable sleep.



## 10CM GRANDE

LENGTH.....200cm  
 WIDTH.....76cm  
 HEIGHT.....10cm  
 PACKED.....76 x Ø23cm  
 WEIGHT.....3.5kg  
 TOG RATING..... 16  
 CARTON QTY.....2  
 STD ORDER QTY.2

HERBAL  
 SMNSHANGRH09RU5



## DOUBLE

LENGTH.....200cm  
 WIDTH.....132cm  
 HEIGHT.....10cm  
 PACKED.....66 x Ø30cm  
 WEIGHT.....5.9kg  
 TOG RATING..... 16  
 CARTON QTY.....2  
 STD ORDER QTY.2

HERBAL  
 SMNSHANGRH09A09



## 15CM GRANDE

LENGTH.....200cm  
 WIDTH.....76cm  
 HEIGHT.....15cm  
 PACKED.....76 x Ø29cm  
 WEIGHT.....5.24kg  
 TOG RATING..... 22  
 CARTON QTY.....2  
 STD ORDER QTY.2

SKY BLUE  
 SMNSHANGRS0DM1M



## DOUBLE

LENGTH.....200cm  
 WIDTH.....132cm  
 HEIGHT.....15cm  
 PACKED.....70 x Ø45cm  
 WEIGHT.....8.9kg  
 TOG RATING..... 22  
 CARTON QTY.....2  
 STD ORDER QTY.2

SKY BLUE  
 SMNSHANGRS0DM1N

# TECHNICAL SLEEP MATS

## VANGO TREK

The Trek sleeping mat range is the perfect choice when durability, strength and affordability are paramount. The small pack size and light weight are ideal features when you need to carry your bed on your back.

- NEW Ben Nevis contour print
- 75D hexagonal ripstop upper.
- Fast-Flow valve - quick and simple push-button operation, locks securely.
- FastPack bag.
- 3cm foam with diamond cut outs - reduces weight, but maintains comfort and insulation
- Repair kit included.
- REACH Approved materials.

3



### SHORT

LENGTH.....122cm  
 WIDTH.....51cm  
 HEIGHT.....3cm  
 PACKED.....26 x Ø13cm  
 WEIGHT.....670g  
 CARTON QTY.....6  
 STD ORDER QTY.6



COBALT  
SMNTREK C17SDC

3



### COMPACT

LENGTH.....160cm  
 WIDTH.....51cm  
 HEIGHT.....3cm  
 PACKED.....26 x Ø14cm  
 WEIGHT.....850g  
 CARTON QTY.....6  
 STD ORDER QTY.6



COBALT  
SMNTREK C17SDI

3



### STANDARD

LENGTH.....183cm  
 WIDTH.....51cm  
 HEIGHT.....3cm  
 PACKED.....26 x Ø16cm  
 WEIGHT.....1kg  
 CARTON QTY.....6  
 STD ORDER QTY.6



COBALT  
SMNTREK C17SDD

3



### LONG

LENGTH.....195cm  
 WIDTH.....60cm  
 HEIGHT.....3cm  
 PACKED.....30 x Ø16cm  
 WEIGHT.....1.3kg  
 CARTON QTY.....6  
 STD ORDER QTY.6



COBALT  
SMNTREK C17SDJ

5



### STANDARD

LENGTH.....183cm  
 WIDTH.....55cm  
 HEIGHT.....5cm  
 PACKED.....26 x Ø21cm  
 WEIGHT.....1.38kg  
 CARTON QTY.....6  
 STD ORDER QTY.6



COBALT  
SMNTREK C17SDE

### SEAT PAD

LENGTH.....40cm  
 WIDTH.....30cm  
 HEIGHT.....4cm  
 PACKED.....32 x Ø8cm  
 WEIGHT.....180g  
 CARTON QTY.....6  
 STD ORDER QTY.6



COBALT  
SMNTREK C17A2E

# F10 AERO

The F10 Series Aero range of sleep mats use lightweight materials to insulate the user and reduce the weight of the mat at no sacrifice to comfort or warmth. Also implementing a non-slip print to ensure your sleeping bag stays on the mat, the Aero is ideal for backpackers who wish for lightweight comfort when on their adventures.

- Fast-Flow valve - quick and simple push-button operation, locks securely.
- FastPack bag
- 20 denier lightweight, durable ripstop polyester.
- Non-slip patterned grip.
- 3cm thick open cell foam.
- High quality TPU lamination.
- Repair kit included.
- REACH Approved materials.

3 

## COMPACT

LENGTH..... 120cm  
WIDTH..... 51cm  
HEIGHT..... 3cm  
PACKED..... 26 x Ø12cm  
WEIGHT..... 500g  
CARTON QTY..... 6



CITRON  
SMNAERO C12SDI

3 

## SHORT

LENGTH..... 168cm  
WIDTH..... 51cm  
HEIGHT..... 3cm  
PACKED..... 26 x Ø15cm  
WEIGHT..... 720g  
CARTON QTY..... 6



CITRON  
SMNAERO C12SDC

3 

## STANDARD

LENGTH..... 183cm  
WIDTH..... 51cm  
HEIGHT..... 3cm  
PACKED..... 27 x Ø16cm  
WEIGHT..... 780g  
CARTON QTY..... 6



CITRON  
SMNAERO C12SDD

3 

## LONG

LENGTH..... 198cm  
WIDTH..... 60cm  
HEIGHT..... 3cm  
PACKED..... 31 x Ø17cm  
WEIGHT..... 950g  
CARTON QTY..... 6



CITRON  
SMNAERO C12SDJ



# PILLOWS

## FOLDAWAY UPDATED

Lay your head on this compact travel pillow designed to fold into its own integral stuffsack making it easy to carry and transport.

- 100% Polyester Microfibre fabric that is extra cosy, snug and comfortable
- 4 Hole hollow fibre insulation
- Stuffsack with convenient drawcord closure

**Length:** 40cm  
**Width:** 27cm  
**Weight:** 220g  
**Carton qty:** 6



**EXCALIBUR**  
PINFOLDAWE27TDC

## SELF-INFLATING UPDATED

The ultimate in effortless comfort, inflates within seconds by simply releasing the valve and allowing air to be drawn into the pillow. Make a good night's sleep even better with a Vango Self Inflating Pillow.

- Brushed polyester top fabric
- Open-cell foam insulation
- Supplied with stuffsack

**Length:** 50cm  
**Width:** 32cm  
**Weight:** 300g  
**Carton qty:** 6  
**Std Order qty:** 25

**SKY BLUE**  
PINSELFINS0DTDC



**HERBAL**  
PINSELFINH09TDC

## COMFORT NEW

Combining the benefits of a full sized pillow from home, with the small pack size of a camping pillow, the Comfort foam pillow brings a high degree of comfort to the campsite.

- Inflatable core giving adjustable level of support
- Fast-Flow valve
- Brushed polyester fabric
- Foam lined for relaxing support
- Fits household pillowcases
- Supplied with stuffsack

**Length:** 55cm  
**Width:** 38cm  
**Weight:** 400g  
**Carton qty:** 6  
**Std Order qty:** 25



**SKY BLUE**  
PINSHANGRS0DTDC

## SHANGRI-LA NEW MEMORY FOAM

Combining the benefits of a fully supported memory foam pillow, with the small pack size of a camping pillow, the Shangri-La is the ultimate in outdoor sleeping luxury.

- Memory foam lined for the perfect individual support
- Inflatable core
- Fast-Flow valve
- Brushed polyester fabric
- Fits household pillowcases
- Supplied with stuffsack

**Length:** 55cm  
**Width:** 38cm  
**Weight:** 420g  
**Carton qty:** 6  
**Std Order qty:** 25



**SKY BLUE**  
PINCOMFORS0DTDC

## LARGE SQUARE UPDATED

our classic Vango Large Square Pillow has had a makeover both inside and out. With a neutral, grey brushed polyester fabric it offers the true comfort and softness of a good quality fabric with a colour that works with everything.

- 100% Polyester Microfibre fabric that is extra cosy, snug and comfortable
- 4 Hole hollow fibre insulation
- Stuffsack with convenient drawcord closure

**Length:** 60cm  
**Width:** 30cm  
**Weight:** 400g  
**Carton qty:** 24  
**Std Order qty:** 6



**EXCALIBUR**  
PINSQUAREE27Z08

## DEEP SLEEP ERGO UPDATED

The Vango Deep Sleep Ergo is an air filled pillow, designed using a stretchy, comfortable fabric for extra relaxation.

- Fast-Flow valve - quick and simple locks securely
- Elasticated outer shell - conforming, flexible and ultra-soft
- Ergonomic shaping - supports head and neck
- Supplied with stuffsack - with drawcord closure

**Length:** 42cm  
**Width:** 27cm  
**Height:** 7cm  
**Weight:** 100g  
**Packed:** 8 x 6cm  
**Carton qty:** 10



**SKY BLUE**  
PINDSERGOS0DTDC

## DEEP SLEEP THERMO UPDATED

Packed in its tiny stuff sack, the Thermo Pillow is super light weight and easily carried on multi day hikes.

- Flat valve - closes flush with pillow surface
- Breathable outer shell - conforming, flexible and ultra-soft
- Hollow fibre insulation - provides additional warmth and extreme comfort
- Supplied with stuffsack - with drawcord closure

**Length:** 45cm  
**Width:** 28cm  
**Height:** 14cm  
**Weight:** 200g  
**Packed:** 10 x 10cm  
**Carton qty:** 10



**TURBULENT BLUE**  
PINDSTHERT04TDC



## ESSENTIALS

*We understand that after picking the ideal tent, campers look to personalise their outdoor home with camping essentials that suit their needs in terms of usability, quality and value. Within our wide range of essentials, we have everything to suit any consumers needs from camp beds to cookware; to water tanks and camping toilets.*

*For 2018, we are excited to launch two new collections within our essentials range which comprises of family cookers including a Combi Infra-red Grill and electric coolers. Meaning you can truly cook up a storm on the campsite.*

*We have also added a new range of electric camping essentials including all the necessary adaptors and leads which are compatible with the new Voltaic Roll Away which is perfect for charging all your essentials such as your phone or tablet while on your camping holiday.*

*Finally, don't forget to check out the exciting updates within our furniture collection such as our new luxurious Kensington chairs, flexible Granite Duo table range or all new Mammoth Duo Wardrobe.*

SLEEP  
FURNITURE  
COOKERS  
COOLERS  
TABLEWARE  
TRAVEL AIDS  
COOKERS  
TOILETS  
ELECTRIC  
LIGHTING  
TECHNICAL

# CAMPBEDS

## HUSH CAMPBED NEW

Enjoy a comfortable night's sleep on this lightweight campbed. Four legs ensure stability, and it folds away to a compact size.

- Steel frame - Strong and reliable
- DuoWeave™ fabric - soft, comfortable and durable.
- Foldable to compact size
- Supplied with Carry Bag

**SIZE** ..... L182 x W58 x H19cm

**FOLDED** ..... W70 x D19 x H9cm

**WEIGHT** ..... 3.46kg

**MAX LOAD** ..... 100kg / 15st 10lbs

**CARTON QTY** ..... 6

**STD ORDER QTY** . 1



EXCALIBUR  
ACNHUSH E27Z05

## MICROLITE CAMPBED NEW

The Microlite Campbed has a new unique lightweight aluminium frame that is easy to assemble making it ideal for relaxing after a long day in the outdoors.

- Foldable to compact size
- 600D polyester - Very strong and durable
- Supplied with Carry Bag
- Locking frame
- Elastic straps for securing sleep mat

**SIZE** ..... W190 x D64 x H12cm

**FOLDED** ..... W70 x D19 x H9cm

**WEIGHT** ..... 2.2kg

**MAX LOAD** ..... 120kg / 18stone 12lbs

**CARTON QTY** ..... 2

**STD ORDER QTY** . 2



EXCALIBUR  
ACNMICROLS0YM1D

## SOMNI DOUBLE NEW

For family camping trips and sleepovers, the Vango Somni Double Campbed is a must have item. The Double, as the name suggests is built for two and is fully supported to avoid sinking in the middle. It will happily accommodate a double airbed or self inflating mattress for added warmth and comfort. It's strong, reliable steel frame means that the bed will be forever stable, and with the help of its angled legs it is impossible to accidentally collapse yet able to fold flat to a compact size. All of the beds in the collection have top and bottom end elastic straps for the attachment of inflatable mattresses. The striking design of the Campbed will complement any Vango tent; awning and furniture, while offering support, no matter whether it's used indoors or out.

- Steel frame - Strong and reliable
- Angled legs - Maximum stability
- Elasticated straps positioned at either end of the bed allow you to secure an inflatable mattress
- Foldable to compact size
- Supplied with Carry Bag

**SIZE** ..... L193.5 x W132 x H46cm

**FOLDED** ..... L23 x W14.5 x H97.5cm

**WEIGHT** ..... 13.4kg

**MAX LOAD** ..... 200kg / 31st 7lbs

**CARTON QTY** ..... 1

**STD ORDER QTY** . 1



EXCALIBUR  
ACNSOMNI E27DBL

Somni double folds to a manageable size and fits easily into its carry bag

97cm

# DORMIR CAMPBEDS

A fresh approach to the design and construction of campbeds has led to the launch of the Dormir collection. The main benefit is how easily they fold down to an industry leading small packed size, making them much more car boot friendly, where space is always a premium for family camping trips. But not only do these beds benefit from a compact pack size, they are also incredibly comfortable and stable, providing a great night sleep. All of the beds in the collection have top and bottom end elastic straps for the attachment of inflatable mattresses. The Dormir camp bed is the epitome of camp comfort.

- Steel frame - Strong and reliable
- Angled legs - Maximum stability
- DuoWeave™ fabric
- Elasticated straps positioned at either end of the bed allow you to secure an inflatable mattress for the upmost luxury
- Integrated carry handles allow the bed to be easily carried when folded and locked. No need for a separate carry bag.
- Slide on pillow made from half mesh and half Duo Weave™ fabric
- Designed specifically to fit exactly into the Standard Vango Inner bedroom compartments
- Folds flat making packing and storing a lot easier.
- Open leg frame - you can store and access bags easily from the ends or sides of your bed.
- Foldable to compact size - Easy storage and transport

## CAMPBED XL NEW

SIZE..... L215 x H31 x W64cm  
 PACKED..... W108 x D6 x H64cm  
 WEIGHT ..... 7.3kg  
 MAX LOAD..... 120Kg / 18stone 12lbs  
 CARTON QTY..... 1  
 STD ORDER QTY. 1



SMOKE  
ACNDORMIRE27S08

## CAMPBED NEW

SIZE..... L183 x H31 x W64cm  
 PACKED..... W91 x D6 x H64m  
 WEIGHT ..... 6.74kg  
 MAX LOAD..... 120Kg / 18stone 12lbs  
 CARTON QTY..... 1  
 STD ORDER QTY. 1



SMOKE  
ACNDORMIRE27M1D

The Dormir Deluxe is made with 2 layers of fabric and a layer of foam sandwiched in between, this bed offers the upmost in luxury. Offering you not only additional comfort, but also extra warmth. Perfect for campers who enjoy luxurious items.

## DELUXE NEW

SIZE..... L183 x H31 x W64cm  
 PACKED..... W64 x D7 x H92cm  
 WEIGHT ..... 7.4kg  
 MAX LOAD..... 120Kg / 18stone 12lbs  
 CARTON QTY..... 1  
 STD ORDER QTY. 1



SMOKE  
ACNDORMIRE27S86

## DELUXE XL NEW

SIZE..... L215 x H31 W64cm  
 PACKED..... W108 x D6 x H64cm  
 WEIGHT ..... 8kg  
 MAX LOAD..... 120Kg / 18stone 12lbs  
 CARTON QTY..... 1  
 STD ORDER QTY. 1



SMOKE  
ACNDORMIRE27SP6

# AIRBEDS

From sleep-overs at home to camping out in the elements, the soft flocked surface of a Vango Airbed will always provide a welcome and comfortable place to rest at the end of the day. The coil beam construction creates a strong and supportive structure, providing a great nights sleep before a day in the outdoors. And there's no need to wait long to stretch out, as this airbed comes equipped with an inflate/deflate valve which allows the bed to be unpacked and inflated quickly.

## DOUBLE AIRBED

- Flocked surface - for maximum comfort.
- Coil beam construction - good support and strong.
- Free-flowing valve - rapid inflation and deflation.
- Repair patches included - for use in emergencies.
- Inflation time 3 minutes.

**SIZE** ..... W191 x D137 x H22cm  
**FOLDED** ..... W30.5 x D29.5 x H11cm  
**MAX LOAD** ..... 240kg / 37st 11lbs  
**CARTON QTY** ..... 4  
**STD ORDER QTY** . 1



NUTMEG  
ACXABED3HCW64

## SINGLE AIRBED

- Flocked surface - for maximum comfort.
- Coil beam construction - good support and strong.
- Free-flowing valve - rapid inflation and deflation.
- Repair patches included - for use in emergencies.
- Inflation time 2 minutes.

**SIZE** ..... W191 x D73 x H20cm  
**FOLDED** ..... W30 x D29.5 x H7.5cm  
**MAX LOAD** ..... 120kg / 18st 12lbs  
**CARTON QTY** ..... 4  
**STD ORDER QTY** . 1



NUTMEG  
ACXABED3HAW64



DOVE  
ACXABED 3HOW53



## NEST DOUBLE AIRBED

- Coil beam construction
- Repair patches included - For use in emergencies
- Inflation time 2 minute
- Free-flowing valve - Rapid inflation and deflation
- Flocked surface - Extra soft and comfortable
- Compact size

**SIZE** ..... W191 x D120 x H22cm  
**FOLDED** ..... W29 x D23 x H8cm  
**MAX LOAD** ..... 240kg / 37st 11lbs  
**CARTON QTY** ..... 4  
**STD ORDER QTY** . 1

## HI-RISE AIRBED

- 210cm long - Ideal for taller people.
- Flocked surface - for maximum comfort.
- Coil beam construction - good support and strong.
- 2 layer in height - easier to get up from bed.
- Inflation time 5 minutes.
- Repair patches included - for use in emergencies.
- Raised edges improves firmness and stability.

**SIZE** ..... W210 x D157 x H38cm  
**FOLDED** ..... W41 x D33 x H16cm  
**MAX LOAD** ..... 240kg / 37st 11lbs  
**CARTON QTY** ..... 2  
**STD ORDER QTY** . 1



NUTMEG  
ACXABED3HFW64

# AIRHEAD SINGLE AIRBED

- Coil beam construction - good support and strong.
- Flocked surface - for maximum comfort.
- Repair patches included - for use in emergencies.
- 212cm long - ideal for taller people.
- Inflatable headboard - provides homely comfort.
- Inflation time 3 minutes.

**SIZE**..... W212 x D73 x H55cm

**FOLDED**..... W30 x D24.5 x H8cm

**MAX LOAD**..... 120kg / 18st 12lbs

**CARTON QTY**..... 4

**STD ORDER QTY.** 1



NUTMEG  
ACXABED3HKW64

# AIRHEAD DOUBLE AIRBED

- Coil beam construction - good support and strong.
- Flocked surface - for maximum comfort.
- Repair patches included - for use in emergencies.
- 212cm long - ideal for taller people.
- Inflatable headboard - provides homely comfort.
- Inflation time 4 minutes.

**SIZE**..... W212 x D137 x H65cm

**FOLDED**..... W37 x D27 x H11cm

**MAX LOAD**..... 240kg / 37st 11lbs

**CARTON QTY**..... 4

**STD ORDER QTY.** 1



NUTMEG  
ACXABED3HLW64



## FREE-FLOWING VALVE

Rapid inflation and deflation.

# INFLATABLE COLLECTION

## DLX CHAIR

Quick to inflate and great for unwinding, the Vango Inflatable Deluxe Flocked Chair is hardwearing and comfortable. Made from soft flocked PVC, it provides a pleasant surface to relax on which will also do no harm to groundsheets and tent.

- Extra soft, comfortable flocked surface.
- Repair patches included.

**SIZE** ..... W85 x D85 x H53cm  
**FOLDED** ..... W30 x D6 x H24.5cm  
**WEIGHT** ..... 956g  
**MAX LOAD** ..... 120kg / 18st 12lbs  
**CARTON QTY** ..... 8  
**STD ORDER QTY** . 1



## CHAIR

Quick to inflate and great for unwinding, the Vango Inflatable Flocked Chair is hardwearing and comfortable. Made from soft flocked PVC, it provides a pleasant surface to relax on which will also do no harm to groundsheets and tent.

- Extra soft, comfortable flocked surface.
- Repair patches included.

**SIZE** ..... W94 x D83 x H76cm  
**FOLDED** ..... W37 x D6 x H27cm  
**WEIGHT** ..... 1.65kg  
**MAX LOAD** ..... 120kg / 18st 12lbs  
**CARTON QTY** ..... 6  
**STD ORDER QTY** . 1



## LOUNGER

Sit back and relax in the new Inflatable Lounger. With its flocked, contoured and curved surface combined with a comfortable backrest, the Lounger is a must-have for all camping trips, whether relaxing inside or out.

- 2 layer in height - easier to get up from.
- Coil beam construction - good support and strong.
- Flocked surface - for comfort.
- Free-flowing valve - rapid inflation and deflation.
- Repair patches included.

**SIZE** ..... W108 x D125 x H94cm  
**FOLDED** ..... W37 x D9 x H27cm  
**WEIGHT** ..... 1.94kg  
**MAX LOAD** ..... 120kg / 18st 12lbs  
**CARTON QTY** ..... 6  
**STD ORDER QTY** . 1



## SOFA

Its maximum loading weight of 250kg makes this the ideal piece of furniture for relaxing with friends in the campsite or at a festival, where the Inflatable Sofa creates a home-from-home feel.

- 2 person sofa - great for outside and inside use.
- Extra soft, comfortable flocked surface.
- Repair patches included.

**SIZE** ..... W138 x D87 x H71cm  
**FOLDED** ..... W37 x D10 x H27cm  
**WEIGHT** ..... 2.84kg  
**MAX LOAD** ..... 250kg / 39st 5lbs  
**CARTON QTY** ..... 4  
**STD ORDER QTY** . 1



# INFLATABLE COLLECTION

## SINGLE SOFABED

The ultimate in versatility and comfort, featuring a 2-in-1 lounging system. New to the Vango furniture collection, this sofabed can be used as a comfy, living area seating area, or as an extra bed for camping sleepovers or additional guests. Space saving and versatile!

- 2 layer in height - easier to get up from.
- Coil beam construction - good support and strong.
- Flocked surface - for comfort.
- Free-flowing valve - rapid inflation and deflation.
- Repair patches included.

**SIZE** ..... W95 x D215 x H65cm (sofabed)  
W95 x D112 x H85cm (chair)

**FOLDED** ..... W41 x D12 x H33cm

**WEIGHT** ..... 3.94kg

**MAX LOAD** ..... 120kg / 18st 12lbs

**CARTON QTY** ..... 4

**STD ORDER QTY** . 1



NUTMEG  
ACMINFLAT33MW64



## RELAXER CHAIR SET (PAIR)

Featuring a comfortable and supportive wide back design and flocked surface, the Inflatable Relaxer Chair Set will be the place to be at the end of the day in the great outdoors. The easy flow valve will make inflating and deflating effortless, making it the perfect addition to the campsite or at a festival.

- 2 layer in height - easier to get up from.
- Coil beam construction - good support and strong.
- Flocked surface - for comfort.
- Free-flowing valve - rapid inflation and deflation.
- Repair patches included.

**SIZE** ..... W114 x D85 x H64cm (per chair)

**FOLDED** ..... W41 x D13 x H33cm (per chair)

**WEIGHT** ..... 4.49kg (per set of 2)

**MAX LOAD** ..... 120kg / 18st 12lbs

**CARTON QTY** ..... 4

**STD ORDER QTY** . 1



NUTMEG  
ACMINFLAT33JW64

## DOUBLE SOFABED NEW

Made to share, the Vango Inflatable Double Sofa bed is constructed from strong PVC material for added durability, with a comfortable flocked exterior. Its impressive loading weight of 250kg makes this the ideal piece of furniture for relaxing with friends in the campsite or at a festival. It's also ideal for putting up visitors, as it quickly converts to a double bed, providing a truly versatile piece of furniture that creates a home-from-home feel.

- 2 layer in height - easier to get up from.
- Coil beam construction - good support and strong.
- Flocked surface - for comfort.
- Free-flowing valve - rapid inflation and deflation.
- Repair patches included.

**SIZE** ..... W177 x D116 x H107m (Chair)

W177 x D250 x H107cm (Sofa bed)

**FOLDED** ..... W41 x D16.5 x H33cm

**WEIGHT** ..... 6.9kg

**MAX LOAD** ..... 250kg / 39st 5lbs

**CARTON QTY** ..... 2

**STD ORDER QTY** . 1



NUTMEG  
ACNINFLAT3AIW64



# PUMPS

## DC PUMP

This compact electric pump can be connected to the adaptor in your car to make inflation and deflation at the campsite quick and effortless. Ideal for outdoor, camping and home use.

- Car adaptor included.
- Inflates and deflates.
- Multiple nozzle options included.

**SIZE** ..... L11.6 x W9.9 x H11cm  
**PACKED** ..... L13 x W10 x H12cm  
**WEIGHT** ..... 310g  
**CARTON QTY** ..... 24  
**STD ORDER QTY** . 1



ACXPUMP35FZ01

## RECHARGEABLE PUMP

For those trips where you have little or no access to a power source, the Vango Rechargeable Pump, can be charged in advance and used without needing to plug in.

- Car adaptor, UK plug and EU adaptor included
- Inflates and deflates
- Multiple nozzle options included

**SIZE** ..... L11.7 x W9.9 x H11.4cm  
**PACKED** ..... L14 x W10.5 x H13cm  
**WEIGHT** ..... 655g  
**CARTON QTY** ..... 24  
**STD ORDER QTY** . 1



ACXPUMP369Z01

## AIRBEAM® DC DIGITAL PUMP

With a powerful internal motor, soft-touch LED digital display, auto cut-off and multiple nozzle options, the Vango AirBeam® Digital Pump is packed with features to make tent and awning pitching faster and easier.

- LED digital display with auto cut-off.
- Easy grip handle.
- 1.5m air hose.
- 1.5m cable with built-in car adaptor.
- 6.5m extension cable with built-in car adaptor.
- Multiple nozzle options included

**SIZE** ..... L22 x W17 x H17cm  
**PACKED** ..... L23 x W18 x H18.5cm  
**WEIGHT** ..... 1.72kg  
**CARTON QTY** ..... 4  
**STD ORDER QTY** . 1



ACXPUMP 397W32

## AC/DC PUMP

This versatile and compact electric pump can be connected, not only to your car's adaptor, but also to a standard UK mains socket. An invaluable tool on the campsite.

- Car adaptor, UK plug and EU adaptor included
- Inflates and deflates
- Multiple nozzle options included

**SIZE** ..... L11 x W9 x H10.2cm  
**PACKED** ..... L14.5 x W10.5 x H12.5cm  
**WEIGHT** ..... 830g  
**CARTON QTY** ..... 12  
**STD ORDER QTY** . 1



ACXPUMP35NZ01

## AIR PUMP

The NEW Vango Double Action AirPump will inflate and deflate tents, awnings, airbeds, furniture and any other inflatables with ease. This pump has been updated with a taller design making it even easier to inflate all of your air essentials.

- Alloy shaft - provides maximum strength.
- Inflates and deflates.
- Multiple nozzle options included.

**SIZE** ..... L22.5 x W9 x H58cm  
**PACKED** ..... L23 x W9.5 x H59cm  
**WEIGHT** ..... 950g  
**CARTON QTY** ..... 4  
**STD ORDER QTY** . 1



ACXPUMP398Z65

# STOOL COLLECTION

## STEEL

A lightweight steel stool that is easy to transport and compact for storage.

### CORONADO

- DuoWeave fabric.
- Strong, steel, textured frame.
- Opens and fold quickly.
- Foldable to compact size.

**SIZE** ..... W44 x D35 x H47cm  
**FOLDED** ..... W45 x D2.5 x H59cm  
**WEIGHT** ..... 1.46kg  
**MAX LOAD** ..... 80kg / 12st 8lbs  
**CARTON QTY** ..... 6  
**STD ORDER QTY** .6



EXCALIBUR  
CHNCRNADOE27TDC

### ORMOND

- DuoWeave fabric.
- Strong, steel, textured frame.
- Opens and fold quickly.
- Foldable to compact size.
- Built-in carry strap.

**SIZE** ..... W39 x D34 x H45/76cm  
**FOLDED** ..... W85 x D16 x H9cm  
**WEIGHT** ..... 1.24kg  
**MAX LOAD** ..... 100kg / 15st 10lbs  
**CARTON QTY** ..... 6  
**STD ORDER QTY** .6



EXCALIBUR  
CHNORMONDE27TDC

### MONARCH

- DuoWeave fabric.
- Strong, steel, textured frame.
- Opens and fold quickly.
- Foldable to compact size.
- Built-in carry strap.

**SIZE** ..... W45 x D28/45 x H45/81cm  
**FOLDED** ..... W65 x D48 x H9cm  
**WEIGHT** ..... 2.84kg  
**MAX LOAD** ..... 120kg / 18st 12lbs  
**CARTON QTY** ..... 6  
**STD ORDER QTY** .6



EXCALIBUR  
CHNMONARCE27TDC

## ALUMINIUM

A lightweight aluminium stool that is easy to transport and compact for storage.

### BALMORAL <sup>UPDATED</sup>

- 600D polyester seat.
- Lightweight aluminium tripod frame.
- Opens and fold quickly.
- Foldable to compact size.
- Built-in carry strap.

**SIZE** ..... W34 x D32 x H39cm  
**FOLDED** ..... W8 x D8 x H54cm  
**WEIGHT** ..... 500g  
**MAX LOAD** ..... 100kg / 15st 10lbs  
**CARTON QTY** ..... 6  
**STD ORDER QTY** .6



SMOKE  
ACMCHAIRRN2W28

## ALUMINIUM - TECHNICAL

Durable fabric and a lightweight aluminium frame, the flat-footed, 4-leg structure enhance stability.

### SKYE TALL <sup>UPDATED</sup>

- 600D polyester seat.
- Aluminium frame - lightweight and strong.
- Flat foot design - groundsheets friendly.
- Foldable to compact size.
- Supplied with carry bag.

**SIZE** ..... W32 x D32 x H35cm  
**FOLDED** ..... W8 x D8 x H42cm  
**WEIGHT** ..... 460g  
**MAX LOAD** ..... 100kg / 15st 10lbs  
**CARTON QTY** ..... 6  
**STD ORDER QTY** .6



SMOKE  
CHNSKYE 50YTD

# MICROLITE COLLECTION

The Microlite Collection features a lightweight alloy frame and is made from Vango's extra strength 600D polyester, making it ideal for taking to festivals or sitting round the campsite at the end of the day.

## MICROLITE UPDATED

- 600D polyester - Very strong and durable
- Aluminium frame - Lightweight and strong
- Supplied with Carry Bag - Folds into compact carry bag for convenient transportation

**SIZE**..... W50 x D45 x H67cm  
**FOLDED**..... W44 x D12 x H8cm  
**WEIGHT** ..... 1.1kg  
**MAX LOAD**..... 120kg / 18st 12lbs  
**CARTON QTY**..... 2  
**STD ORDER QTY** .2



**SMOKE**  
CHNIMICROLSOYTDC

## MICROLITE TALL UPDATED

- 600D polyester - Very strong and durable
- Aluminium frame - Lightweight and strong
- Supplied with Carry Bag - Folds into compact carry bag for convenient transportation
- A tall frame design that offers more support for you back to ensure maximum comfort when relaxing

**SIZE**..... W69 x D55 x H100cm  
**FOLDED**..... W50 x D13 x H12cm  
**WEIGHT** ..... 1.45kg  
**MAX LOAD**..... 120kg / 18st 12lbs  
**CARTON QTY**..... 2  
**STD ORDER QTY** .2

**SMOKE**  
CHNIMICROLSOYTDP



## MICROLITE XL NEW

- 600D polyester - Very strong and durable
- Aluminium frame - Lightweight and strong
- Wrap-around fabric reduces draughts that can sneak through gaps between the fabric and frame
- Ergonomic design for dining comfortably round the table

**SIZE**..... W55 x D55 x H83cm  
**PACKED**..... W48 x D12 x H12cm  
**WEIGHT** ..... 2.35kg  
**MAX LOAD**..... 120kg / 18st 12lbs  
**CARTON QTY**..... 2  
**STD ORDER QTY** .2

**SMOKE**  
CHNIMICROLSOYS08



## MICROLITE DLX NEW HERO

- Aluminium frame - Lightweight and strong
- Supplied in carry bag
- Foldable to compact size - Easy storage and transport
- 600D polyester - Very strong and durable
- A tall frame design that offers more support for you back to ensure maximum comfort when relaxing
- Built-in arms provide additional comfort and a handy cup holder to store you drink
- Wrap-around fabric reduces draughts that can sneak through gaps between the fabric and frame

**SIZE**..... W66.5 x D83.5 x H100cm  
**PACKED**..... W50 x D16 x H13cm  
**WEIGHT** ..... 1.73kg  
**MAX LOAD**..... 120kg / 18st 12lbs  
**CARTON QTY**..... 2  
**STD ORDER QTY** .2



## MICROLITE TABLE UPDATED

- Aluminium frame - Lightweight and strong
- Supplied in carry bag
- Foldable to compact size - Easy storage and transport
- 600D polyester - Very strong and durable

**SIZE**..... W60 x D43 x H42cm  
**FOLDED**..... W54 x D8.5 x H8.5cm  
**WEIGHT** ..... 1.1kg  
**MAX LOAD**..... 30kg / 4st 10lbs  
**CARTON QTY**..... 2  
**STD ORDER QTY** .2



**SMOKE**  
TBNMICROLSOYTDC



All of the Microlite collection comes in a bespoke carry bag

# STEEL SOFT ARM CHAIRS

## MALIBU

The superb value Vango Malibu Chair is perfect for relaxing in the great outdoors. Featuring our new DuoWeave® fabric, the surface is soft to touch yet highly durable. The extra padding on the seat and backrest offer the ultimate in comfort.

- DuoWeave fabric
- Texturised frame
- Padded seat, arms and backrest
- Strong, steel frame with comfortable fabric arms
- Insulated cup holder
- Foldable to compact size
- Supplied in carry bag

**SIZE** ..... W50/73 x D41/50  
x H43/84cm

**FOLDED** ..... W18 x D18 x H82cm

**WEIGHT** ..... 2.86kg

**MAX LOAD** ..... 120kg / 18st 12lbs

**CARTON QTY** ..... 2

**STD ORDER QTY** . 2



EXCALIBUR  
CHNMALIBUE27TDC

## DEL MAR

The great value Del Mar is the perfect chair for relaxing in the sun. Updated with Vango's DuoWeave® fabric, the Del Mar combines soft to touch fabrics and superb resilience to provide a highly comfortable place to be at the end of the day.

- DuoWeave fabric
- Texturised frame
- Reclined position.
- Padded seat, arms and backrest.
- Strong, steel frame with comfortable fabric arms.
- Insulated cup holder.
- Foldable to compact size.
- Supplied in carry bag.

**SIZE** ..... W50/78 x D40/75 x H42/96cm

**FOLDED** ..... W19 x D19 x H98cm

**WEIGHT** ..... 3.58kg

**MAX LOAD** ..... 120kg / 18st 12lbs

**CARTON QTY** ..... 2

**STD ORDER QTY** . 2



EXCALIBUR  
CHNDELMARE27TDC

## CORONA RECLINER

The Corona Recliner features a strong steel, reliable frame, perfect for relaxing on the campsite. This recliner also features Vango's new DuoWeave® fabric, combining superb comfort and long lasting durability.

- DuoWeave fabric
- Texturised frame
- Adjustable frame - 3 seating positions
- Padded seat, arms and backrest.
- Strong, steel frame with comfortable fabric arms.
- Insulated cup holder.
- Foldable to compact size.
- Supplied in carry bag.

**SIZE** ..... W56/89 x D43/75 x H48/104cm

**FOLDED** ..... W20 x D20 x H104cm

**WEIGHT** ..... 4.20kg

**MAX LOAD** ..... 120kg / 18st 12lbs

**CARTON QTY** ..... 2

**STD ORDER QTY** . 2



EXCALIBUR  
CHNCORONAE27TDC

# OVERSIZED STEEL CHAIRS

## SAMSON

The Vango Samson oversized chair has been designed for anyone looking for extra space and strength in their furniture while outdoors – whether that is on the campsite or in the garden. The Samson is the ultimate in reliable camping furniture.

- DuoWeave fabric
- Texturised frame
- Oversized design - extra strong, extra wide, increased load bearing up to 180kg/28st 4lbs
- Steel frame with comfortable fabric arms
- Padded seat and backrest
- Insulated cup holder
- Foldable to compact size
- Supplied with carry bag

**SIZE** ..... W60/92 x D50/60 x H47/104cm  
**FOLDED** ..... W21 x D19 x H97cm  
**WEIGHT** ..... 3.96kg  
**MAX LOAD** ..... 180kg / 28st 4lbs  
**CARTON QTY** ..... 2  
**STD ORDER QTY** . 2



## KRAKEN CORE

The Vango Kraken Oversized chair has been designed larger than the average chair, ideal for anyone looking for extra space and comfort while relaxing outdoor. The Kraken is the ultimate in comfortable, reliable camping furniture.

- DuoWeave fabric
- Texturised frame
- Oversized design - extra strong, extra wide, increased load bearing up to 180kg/28st 4lbs.
- Steel hard arm - strong and extremely stable.
- Locking steel frame.
- Padded seat and backrest.
- Foldable to compact size.
- Supplied with carry bag.

**SIZE** ..... W64/67 x D47/61 x H47/95cm  
**FOLDED** ..... W23 x D21 x H89cm  
**WEIGHT** ..... 4.80kg  
**MAX LOAD** ..... 180kg / 28st 4lbs  
**CARTON QTY** ..... 2  
**STD ORDER QTY** . 2



## KRAKEN TALL

The Vango Kraken Tall chair has been designed larger than the average chair, ideal for anyone looking for extra space and comfort while relaxing outdoor. The Kraken is the ultimate in comfortable, reliable camping furniture.

- DuoWeave fabric
- Texturised frame
- Oversized design - extra strong, extra wide, increased load bearing up to 180kg/28st 4lbs.
- Steel hard arm - strong and extremely stable.
- Locking steel frame.
- Padded seat and backrest.
- Reinforced headrest for added support.
- Foldable to compact size.
- Supplied with carry bag.

**SIZE** ..... W64/67 x D47/61 x H47/112cm  
**FOLDED** ..... W23 x D21 x H96cm  
**WEIGHT** ..... 5.0kg  
**MAX LOAD** ..... 180kg / 28st 4lbs  
**CARTON QTY** ..... 2  
**STD ORDER QTY** . 2



## TITAN CORE

The Titan is the ultimate in comfort and reliability, featuring a strong and robust steel frame. Vango's brand new fabric DuoWeave® provides a perfect balance between superb comfort and long lasting durability.

- DuoWeave fabric
- Texturised frame
- Oversized design - extra strong, extra wide, increased load bearing up to 180kg/28st 4lbs.
- Strong steel frame.
- Padded seat and backrest.
- Wrap around design for maximum comfort.
- Foldable to compact size.
- Supplied in carry bag.

**SIZE** ..... W53/87 x D58/75 x H47/93cm  
**FOLDED** ..... W30 x D25 x H105cm  
**WEIGHT** ..... 6.30kg  
**MAX LOAD** ..... 180kg / 28st 4lbs  
**CARTON QTY** ..... 2  
**STD ORDER QTY** . 2



# STEEL HARD ARM CHAIRS

## DELRAY

*The Vango Delray is a steel, hard-armed low chair, providing great support and stability. The wide flat feet design spreads the weight when on soft ground, making it ideal for all camping trips, relaxing on the beach or for a welcome break at festivals.*

- DuoWeave fabric.
- Texturised frame.
- Steel hard arm - very stable frame with increased weight loading.
- Steel frame - strong and reliable
- Flat foot design - groundsheet friendly.
- Foldable to compact size.
- Supplied with carry bag.

**SIZE** ..... W53/57 x D40/58 x H24/66cm

**FOLDED** ..... W17 x D15 x H77cm

**WEIGHT** ..... 3.10kg

**MAX LOAD** ..... 120kg / 18st 12lbs

**CARTON QTY** ..... 2

**STD ORDER QTY** .2



EXCALIBUR  
CHNDELRAYE27TDC

## KIRRA

*Strength, comfort and style abound in the fantastic Kirra with a padded back and seat for luxurious comfort, and a new pattern design to complement your Vango tent or awning. Perfect for families who love to feel at home in the campsite, the Kirra really is the crème de la crème of camping chairs.*

- DuoWeave fabric.
- Texturised frame.
- Steel hard arm - very stable frame with increased weight loading.
- Steel frame - strong and reliable.
- Flat foot design - groundsheet friendly.
- Padded seat and backrest.
- Foldable to compact size.
- Supplied with carry bag.

**SIZE** ..... W53/66 x D38/69 x H47/95cm

**FOLDED** ..... W25 x D15 x H109cm

**WEIGHT** ..... 4.80kg

**MAX LOAD** ..... 120kg / 18st 12lbs

**CARTON QTY** ..... 2

**STD ORDER QTY** .2



EXCALIBUR  
CHNKIRRA E27TDC

# STEEL HARD ARM CHAIRS

## HAMPTON COLLECTION

### HAMPTON TALL CORE

*With 6 seating positions, a padded seat and high backrest, it is ideal for those trips where you just want to sit back and relax. Equally, with its sharp and sophisticated looks, the Hampton Tall is just as at home in the back garden, as it is on the campsite.*

- DuoWeave fabric.
- Texturised frame.
- High weight loading - 140kg.
- Strong, steel frame with hard arms.
- Adjustable frame - with 6 seating positions / 5 reclining positions.
- Padded seat and backrest.
- Foldable for easy pack away.

**SIZE** ..... W49/59 x D40/58 x H44/102cm

**FOLDED** ..... W84 x D58 x H12cm

**WEIGHT** ..... 5.24kg

**MAX LOAD** ..... 140kg / 22st

**CARTON QTY** ..... 2

**STD ORDER QTY** .2



EXCALIBUR  
CHNHAMPTO E271DP

### 6 SEATING / 5 RECLINING POSITIONS



# HAMPTON DLX CORE

*Padded for comfort, with an ergonomic hi-back design, six seating positions and adjustable sliding backrest or headrest. The Hampton DLX is perfect for camping, caravanning, motorhomes or just lounging in the garden.*

- DuoWeave fabric.
- Texturised frame.
- Weight loading up to 140kg.
- Strong, steel frame with hard arms
- Adjustable frame - with 6 seating positions / 5 reclining positions
- Padded seat and backrest with adjustable sliding cushion
- Foldable for easy pack away

**SIZE** ..... W49/59 x D40/58 x H44/116cm  
**FOLDED** ..... W97 x D58 x H12cm  
**WEIGHT** ..... 5.64kg  
**MAX LOAD** ..... 140kg / 22st  
**CARTON QTY** ..... 2  
**STD ORDER QTY** . 2



EXCALIBUR  
CHNHAMPTOE27T18

# HAMPTON RELAXER

*This high quality lounge is the perfect relaxation station for an outdoor life on the camping or caravan site. With its stylish looks, it is equally great for enjoying the sunshine in the garden at home.*

- DuoWeave fabric.
- Texturised frame.
- Weight loading up to 140kg.
- Unlock, push back to desired position, then lock.
- Strong, steel frame with hard arms.
- Padded seat and backrest with adjustable sliding cushion.
- Foldable for easy pack away.

**SIZE** ..... W52 x D57 x H54/118cm  
**FOLDED** ..... W96 x D70 x H11cm  
**WEIGHT** ..... 8.54kg  
**MAX LOAD** ..... 140kg / 22st  
**CARTON QTY** ..... 1  
**STD ORDER QTY** . 1



EXCALIBUR  
CHNHAMPTOE27TDP



# ALUMINIUM CHAIRS

## KENSINGTON COLLECTION NEW

The lightweight aluminium frame, makes the Kensington Chair a strong and durable addition to your camping essentials. Combining our luxury DuoWeave™ fabric with a padded seat, makes it perfect for relaxing after a long day in the outdoors. This versatile chair offers up to 7 different seating positions and can fold flat for easy transportation and storage.

- Aluminium frame - Lightweight and strong
- Adjustable Frame - with 7 seating options (from straight backed, to very relaxed)
- Padded seat and backrest - Added layer of comfort and luxury
- Folds flat - Easy storing and transport
- DuoWeave™ fabric - Vango's DuoWeave™ fabric is set to revolutionise the design of furniture for outdoor living. It is extremely resilient, whilst being soft to the touch, providing a perfect balance between superb comfort and long lasting durability
- Oval frame design - Allows furniture to pack away completely flat
- Maximum loading weight of 120kg / 18stone 12lbs



EXCALIBUR  
CHNKENSINE27TDP

## KENSINGTON

SIZE ..... W48/65 x D41/58 x H46/111 cm

FOLDED ..... W65 x D12 x H104cm

WEIGHT ..... 5.04kg

MAX LOAD ..... 120kg / 18st 12lbs

CARTON QTY ..... 2

STD ORDER QTY . 2



EXCALIBUR  
CHNKENSINE27TDC

## KENSINGTON TALL HERO

SIZE ..... W48/65 x D41/58 x H45/120cm

FOLDED ..... W63 x D12 x H112cm

WEIGHT ..... 5.18kg

MAX LOAD ..... 120kg / 18st 12lbs

CARTON QTY ..... 2

STD ORDER QTY . 2

### 6 RECLINING POSITIONS



# STEEL TABLES

## ROWAN

Lightweight table, perfect for enjoying meals at the campsite or back garden. Folds flat with a carry handle for easy transportation.

- Texturised frame.
- Easy clean work surface.
- Steel frame - strong and reliable, folds flat.
- Carry handle.

**SIZE** ..... W80 x D60 x H69cm

**FOLDED** ..... W80 x D60 x H4.5cm

**WEIGHT** ..... 3.50kg

**MAX LOAD** ..... 30kg / 4st 10lbs

**CARTON QTY** ..... 1

**STD ORDER QTY** . 1



TBNROWAN S04TDC

## ASPEN

Lightweight and compact, ideal for weekend camping trips. It will comfortably seat four people for evening meals or a place for kids to sit and play.

- Texturised frame.
- Easy clean work surface.
- Steel frame - strong and reliable, folds flat.
- Carry handle.

**SIZE** ..... W100 x D61 x H71cm

**FOLDED** ..... W100 x D62.5 x H3.5cm

**WEIGHT** ..... 3.90kg

**MAX LOAD** ..... 30kg / 4st 10lbs

**CARTON QTY** ..... 1

**STD ORDER QTY** . 1



TBNASPEN S04TDC

## BIRCH

A great camping table with 4 adjustable legs for uneven ground making it reliable for any camping trip..

- Easy clean hardtop work surface
- Steel frame - strong and reliable, folds flat.
- Adjustable legs - perfect for uneven ground.

**SIZE** ..... W80 x D60 x H50/69cm

**FOLDED** ..... W61.5 x D5.5 x H82cm

**WEIGHT** ..... 6.66kg

**MAX LOAD** ..... 50kg / 7st 12lbs

**CARTON QTY** ..... 1

**STD ORDER QTY** . 1



TBNBIRCH W02TDC

## ORCHARD TABLE & CHAIR SET

The Orchard features a large table and four folding chairs, this set is the perfect accessory to your camping equipment whether you are enjoying breakfast before a big day or sitting down to a family meal on the campsite.

- Moulded tabletop and chairs - lightweight and durable.
- Easy to clean work surface.
- 4 folding chairs included.
- Foldable steel frame - strong and reliable.
- Carry handle.
- Handled carry bag.

**SIZE** ..... W86 x D86 x H71cm (table)

W46 x D40 x H72cm (chairs)

**FOLDED** ..... W86 x D44.5 x H6cm (table)

W86 x D44.5 x H25cm (table/chairs)

**WEIGHT** ..... 14.40kg

**MAX LOAD** ..... 80kg / 12st 8lbs (table)

100kg / 15st 10lbs (chairs)

**CARTON QTY** ..... 1

**STD ORDER QTY** . 1



TBNORCHARG10TDC

# FOLDING TABLES

## GRANITE DUO HERO

A solid and sturdy table with a highly durable table top finish. Using a lightweight and compact aluminium frame, these family camping tables are versatile and easy to use. The legs can be secured at either dining or coffee table height and they also fold down into a compact carry case, making storage and transportation simple.

- Carry case design - No storage bag required
- Table work surface - Lightweight and easy to clean
- Aluminium frame - Lightweight and strong
- Foldable to compact size - Easy storage and transport
- Table changes from a dining table height to a coffee table height
- Adjustable feet - Adjust height to variances in the ground level for stability
- Adjustable legs attach under the table for easy storage and compact folding
- Granite effect table top design gives a modern look and is extremely resilient

### 60 NEW

**SIZE**..... W60 x D40 x H24/54cm  
**FOLDED**..... W31 x D6 x H42cm  
**WEIGHT** ..... 1.8kg  
**MAX LOAD**..... 30kg / 4st 10lbs  
**CARTON QTY**..... 1  
**STD ORDER QTY** . 1



TBNGRANITE27065

### 90 NEW

**SIZE**..... W60 x D60 x H37/72cm  
**FOLDED**..... W61 x D7 x H45cm  
**WEIGHT** ..... 3.58kg  
**MAX LOAD**..... 30kg / 4st 10lbs  
**CARTON QTY**..... 1  
**STD ORDER QTY** . 1



TBNGRANITE27075

### 120 NEW

**SIZE**..... W120 x D80 x H37/71cm  
**FOLDED**..... W81 x D7 x H60cm  
**WEIGHT** ..... 5.86kg  
**MAX LOAD**..... 30kg / 4st 10lbs  
**CARTON QTY**..... 1  
**STD ORDER QTY** . 1



TBNGRANITE27086

### 120H NEW

3 heights - coffee table/dining table/worktop

**SIZE**..... W120 x D40 x H41/71/91cm  
**FOLDED**..... W61.5 x D7.5 x H42cm  
**WEIGHT** ..... 3.38kg  
**MAX LOAD**..... 30kg / 4st 10lbs  
**CARTON QTY**..... 1  
**STD ORDER QTY** . 1



TBNGRANITE27THO

### 160 NEW

**SIZE**..... W160 x D80 x H33/70.5cm  
**FOLDED**..... W62x D15 x H23.5cm  
**WEIGHT** ..... 8.08kg  
**MAX LOAD**..... 30kg / 4st 10lbs  
**CARTON QTY**..... 1  
**STD ORDER QTY** . 1



TBNGRANITE27121

Two tables in one!

All Granite Duo tables double as coffee tables  
 The 120H extends to worktop height too!



# ALUMINIUM TABLES

## CYPRESS

*Small and compact, ideal for those camping in tents with limited space or as a bed side table.*

- Easy clean work surface.
- Aluminium frame - lightweight and strong.
- Folds flat to compact size.

**SIZE** ..... W56 x D34 x H24cm

**FOLDED** ..... W56 x D34 x H3cm

**WEIGHT** ..... 1.12kg

**MAX LOAD** ..... 30kg / 4st 10lbs

**CARTON QTY** ..... 1

**STD ORDER QTY** . 1



## HAWTHORN

*Compact side table, keeps your valuables such as your mobile phone and jewellery by your side.*

- Durable slatted aluminium top.
- Aluminium frame - legs fold flat.
- Adjustable locking legs 11-16cm.
- Carry bag.

**SIZE** ..... W40 x D28.5 x H11/16cm

**FOLDED** ..... W40 x D9 x H6.5cm

**WEIGHT** ..... 760g

**MAX LOAD** ..... 30kg / 4st 10lbs

**CARTON QTY** ..... 1

**STD ORDER QTY** . 1



## ALDER

*A lightweight 6 person table, perfect for families or groups of friends looking for a spacious table to host meals or barbecues.*

- Ideal for seating 6 people.
- Easy clean, work surface.
- Aluminium frame legs - fold flat.
- Folds into carry case with handle.

**SIZE** ..... W180 x D60 x H73cm

**FOLDED** ..... W63 x D61.5 x H11cm

**WEIGHT** ..... 8.98kg

**MAX LOAD** ..... 30kg / 4st 10lbs

**CARTON QTY** ..... 1

**STD ORDER QTY** . 1



## MULBERRY

*High quality aluminium table. The adjustable leg makes it usable when used on uneven ground. A durable lightweight table for your camping holidays..*

- Durable slatted aluminium top.
- Aluminium frame - legs fold flat.
- Adjustable leg for uneven ground.
- Carry bag.

**SIZE** ..... W110 x D70 x H70cm

**FOLDED** ..... W104.5 x D20.5 x H12cm

**WEIGHT** ..... 5.12kg

**MAX LOAD** ..... 30kg / 4st 10lbs

**CARTON QTY** ..... 1

**STD ORDER QTY** . 1



## ALL WEATHER 80cm

*The All Weather Table uses lightweight materials and a waterproof surface, making this the perfect outdoor dining essential for any camping trip, regardless of the conditions outside.*

- Strong, durable tabletop - perfect for dining in all conditions.
- Aluminium frame - lightweight and strong.
- 4 fully adjustable legs.
- 'Bigfoot' design - flex for stability on uneven ground.

**SIZE** ..... W80 x D60 x H65cm  
**FOLDED** ..... W80 x D60 x H7cm  
**WEIGHT** ..... 4.80kg  
**MAX LOAD** ..... 30kg / 4st 10lbs  
**CARTON QTY** ..... 1  
**STD ORDER QTY** . 1



## ALL WEATHER 115cm

*The All Weather Table uses lightweight materials and a waterproof surface, making this the perfect outdoor dining essential for any camping trip, regardless of the conditions outside.*

- Strong, durable tabletop - perfect for dining in all conditions.
- Aluminium frame - lightweight and strong.
- 4 fully adjustable legs.
- 'Bigfoot' design - flex for stability on uneven ground.

**SIZE** ..... W115 x D70 x H55cm  
**FOLDED** ..... W115 x D70 x H6cm  
**WEIGHT** ..... 7.30kg  
**MAX LOAD** ..... 30kg / 4st 10lbs  
**CARTON QTY** ..... 1  
**STD ORDER QTY** . 1



# BAMBOO TABLES

The Vango Bamboo Table is an elegant and sturdy dining table for a more formal dining experience on the campsite. The hardwearing bamboo tabletop is not only strong but also easy to clean. Combined with the lightweight and adjustable aluminium frame (which ensures the table will stay level even on uneven ground). This sophisticated tabletop with 4 wine glass holders makes the Vango Bamboo Table the zenith of our camping furniture range.

- Lightweight, lockable aluminium frame
- Adjustable legs and feet for uneven ground
- Bamboo table top - strong, easy to clean
- Carry handle
- Wine glass holders

## 80cm UPDATED TBNBAMBOOD04070

**SIZE** ..... W80 x D60 x H65cm  
**FOLDED** ..... W80 x D60 x H5.5cm  
**WEIGHT** ..... 6.36kg  
**MAX LOAD** ..... 80kg / 12st 8lbs  
**CARTON QTY** ..... 1  
**STD ORDER QTY** ..1



## 100cm UPDATED TBNBAMBOOD04077

**SIZE** ..... W100 x D72 x H70cm  
**FOLDED** ..... W100 x D37 x H8.2cm  
**WEIGHT** ..... 7.96kg  
**MAX LOAD** ..... 80kg / 12st 8lbs  
**CARTON QTY** ..... 1  
**STD ORDER QTY** ..1



## 100cm ROUND NEW TBNBAMBOOD04THN

**SIZE** ..... W100 x D100 x H70cm  
**FOLDED** ..... W53 x D102 x H11cm  
**WEIGHT** ..... 10kg  
**MAX LOAD** ..... 80kg / 12st 8lbs  
**CARTON QTY** ..... 1  
**STD ORDER QTY** ..1



## 150cm NEW TBNBAMBOOD04111

**SIZE** ..... W150 x D70 x H70cm  
**FOLDED** ..... W79 x D71.5 x H11cm  
**WEIGHT** ..... 9kg  
**MAX LOAD** ..... 80kg / 12st 8lbs  
**CARTON QTY** ..... 1  
**STD ORDER QTY** ..1



# BAMBOO STORAGE

## STORAGE UNIT

A lightweight aluminium multifunctional unit, ideal for storing food, cooking utensils or as a wardrobe when space is tight. With hard edge shelves for added strength and a fantastic looking and incredibly hard wearing bamboo table top.

- Bamboo table top - easy to clean and very strong.
- Lightweight aluminium frame with adjustable feet.
- 600D polyester - very strong and durable.
- Mesh panel - improves ventilation.
- Storage pocket.
- Hard edge shelves - strong and hardwearing.
- Handled carry bag

**SIZE**..... W60 x D49 x H82cm

**FOLDED**..... W61 x D52 x H10cm

**WEIGHT** ..... 6.45kg

**MAX LOAD**..... 30kg / 4st 10lbs

**CARTON QTY**..... 1

**STD ORDER QTY.** 1



**DUNE**

ACNBAMSTOD04TJ8

## DOUBLE STORAGE UNIT

With a fantastic looking and incredibly hard wearing bamboo table top, along with its adjustable feet for stability on uneven ground, the Bamboo Double Storage Unit offers the most stylish and practical storage solution for the family getaway.

- Bamboo table top - easy to clean and very strong.
- Lightweight aluminium frame with adjustable feet.
- 600D polyester - very strong and durable.
- Mesh panels - improves ventilation.
- Storage pocket.
- Hard edge shelves - strong and hardwearing.
- Handled carry bag

**SIZE**..... W100 x D49 x H82cm

**FOLDED**..... W100 x D52 x H10cm

**WEIGHT** ..... 9.9kg

**MAX LOAD**..... 30kg / 4st 10lbs

**CARTON QTY**..... 1

**STD ORDER QTY.** 1



**DUNE**

ACNBAMSTOD04S68

# STORAGE

## FOLDING ORGANISER

For those longer camping trips away with your family, the Vango Folding Organiser can be a lifesaver. Ideal for keeping your living and sleeping areas clean and tidy - and it folds flat for easy transportation when not in use.

- Polyester with PU coating - weather resistant.
- Folds flat when not in use, with handle.

**SIZE** ..... W58.5 x D36 x H31cm  
**FOLDED** ..... W36 x D3.5 x H31cm  
**WEIGHT** ..... 880g  
**MAX LOAD** ..... 9kg / 20lbs  
**CARTON QTY** ..... 12  
**STD ORDER QTY.** 1



**SMOKE**  
ACMSTORAG0VFW28

## MAMMOTH

The Mammoth Storage Unit can make a huge difference in keeping your tent clean and tidy and is suitable for storing anything, from clothes to food to books and games.

- DuoWeave fabric.
- Texturised frame.
- Steel frame - strong and reliable.
- Hard edge shelves - very strong and hardwearing.
- Mesh panels - improves ventilation.
- Easy to assemble.
- Handled zippered carry bag.

**SIZE** ..... W55 x D48 x H114cm  
**FOLDED** ..... W63 x D55 x H10cm  
**WEIGHT** ..... 5.8kg  
**MAX LOAD** ..... 30kg / 4st 10lbs  
**CARTON QTY** ..... 1  
**STD ORDER QTY.** 1



**EXCALIBUR**  
ACNMAMMOT27TJ8

## MAMMOTH DOUBLE

The Mammoth's double width steel frame is easy to assemble and, combined with its hard-edged shelves, creates a robust and sturdy construction, which surprisingly folds flat and into a carry bag for ease of transportation.

- DuoWeave fabric
- Texturised frame
- Steel frame - strong and reliable
- Hard edge shelves - very strong and hardwearing
- Mesh panels - improves ventilation
- Easy to assemble
- Handled zippered carry bag

**SIZE** ..... W86 x D49 x H114cm  
**FOLDED** ..... W88 x D64 x H10cm  
**WEIGHT** ..... 8.7kg  
**MAX LOAD** ..... 30kg / 4st 10lbs  
**CARTON QTY** ..... 1  
**STD ORDER QTY.** 1



**EXCALIBUR**  
ACNMAMMOT27DBL

## STORAGE ORGANISER

The Vango Storage Organiser provides the perfect solution for your camping storage requirements: a super compact and lightweight storage unit that will ensure you know exactly where everything is.

- Polyester with PU coating - weather resistant.
- 2 fibreglass poles.
- Front zip entry.
- 6 reinforced plastic / 3 fabric shelves.
- Handled carry bag.

**SIZE** ..... W120 x D50 x H70cm  
**FOLDED** ..... W40 x D48 x H2cm  
**WEIGHT** ..... 1.40kg  
**MAX LOAD** ..... 13kg / 2st  
**CARTON QTY** ..... 10  
**STD ORDER QTY.** 1



**SMOKE**  
ACMSTORAGRLLW28

## MAMMOTH DUO WARDROBE

This highly versatile piece of furniture provides an excellent storage solution for either folded clothes or those that need hanging. The Mammoth Duo can either be set up as a wardrobe, which includes a hanging rail and side pockets, or as a four shelf cupboard.

- Hanging pole
- Zipped shelves
- Internal pockets
- DuoWeave fabric
- Texturised frame
- Steel frame - strong and reliable.
- Hard edge shelves - very strong and hardwearing.
- Mesh panels - improves ventilation.
- Easy to assemble.
- Handled zippered carry bag.

**SIZE** ..... W55 x D48 x H148cm  
**FOLDED** ..... W81 x D54 x H10cm  
**WEIGHT** ..... 7.48kg  
**MAX LOAD** ..... 30kg / 4st 10lbs  
**CARTON QTY** ..... 1  
**STD ORDER QTY.** 1



**EXCALIBUR**  
ACNMAMMOT27U16





# KITCHENS

## BISTRO DLX

Ideal for the larger family or the more adventurous cook, as its two work surfaces offers an expansive area to prepare your meals.

- DuoWeave fabric.
- Steel frame - strong and reliable.
- Storage cupboard with 2 shelves and zip door
- Additional shelf for keeping items off the ground
- Mesh waste basket - to keep your area clean.
- Handled carry bag.
- **Kitchen Windshield and Utility Rack available as an optional addition.**

**SIZE** ..... W120 x D49 x H80cm  
**FOLDED** ..... W79 x D50 x H12.5cm  
**WEIGHT** ..... 9.0kg  
**MAX LOAD** ..... 30kg / 4st 10lbs  
**CARTON QTY** ..... 1  
**STD ORDER QTY** . 1



SILVER  
ACMSTORAG0SCW18

## GASTRO

Feel at home with the Vango Gastro, featuring a large table top for preparing camping meals. The Gastro comes fitted with a windshield, protecting your cooking flame from the elements.

- Aluminium tabletop - easy to clean.
- Removable windshield.
- Integrated water basin.
- Aluminium frame - lightweight and strong.
- DuoWeave fabric - strong and durable.
- Storage cupboard with 2 shelves and zip door.
- Hard edge shelves - strong and durable.
- 'Bigfoot' design - flex for stability on uneven ground.
- Handled carry bag.

**SIZE** ..... W122.5 x D46.5 x H86.5/117cm  
**FOLDED** ..... W122 x D50 x H11cm  
**WEIGHT** ..... 9.62kg  
**MAX LOAD** ..... 30kg / 4st 10lbs  
**CARTON QTY** ..... 1  
**STD ORDER QTY** . 1



SILVER  
ACMSTORAG0VW18

## CUISINE

The Vango Cuisine is packed with must-have necessities. Featuring a large table top for work space and built-in wash basin, the washing up couldn't be simpler! The Cuisine kitchen also has storage racks and hanging hooks with mesh bag underneath.

- Aluminium tabletop - easy to clean.
- Integrated water basin.
- Vertical and horizontal racks for storage.
- Hanging hooks for your utensils.
- Aluminium frame - lightweight and strong.
- Mesh bag for storage or rubbish disposal.
- 'Bigfoot' design - flex for stability on uneven ground.
- Carry handle.
- Handled carry bag.

**SIZE** ..... W100 x D50 x H81/128cm  
**FOLDED** ..... W101 x D51 x H14cm  
**WEIGHT** ..... 10.76kg  
**MAX LOAD** ..... 30kg / 4st 10lbs  
**CARTON QTY** ..... 1  
**STD ORDER QTY** . 1



SILVER  
ACMSTORAG0VHW18

## UTILITY RACK

If you insist on a tidy campsite then the Vango Utility Rack is what you need. Its solid A-frame construction allows you to hang your cutlery and kitchen utensils away from the ground, keeping them clean and ensuring nothing goes missing.

- Ideal for hanging pots and cooking utensils.
  - Compatible with Bistro DLX.
- SIZE** ..... W33 x H47cm  
**FOLDED** ..... W61 x D4.5 x H2cm  
**WEIGHT** ..... 240g  
**CARTON QTY** ..... 12  
**STD ORDER QTY** . 1

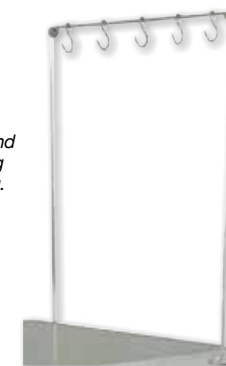

SILVER  
ACMSTORAG0SEW18

## KITCHEN WINDSHIELD

The Vango Kitchen Windshield is perfect for protecting your stove from draughts and winds.

- Helps reduce cooking times by protecting the flame on the stove from draughts and wind.
  - Compatible with Bistro DLX.
- SIZE** ..... W62 x D33 x H31cm  
**FOLDED** ..... W62 x D33 x H1cm  
**WEIGHT** ..... 1.0kg  
**CARTON QTY** ..... 12  
**STD ORDER QTY** . 1

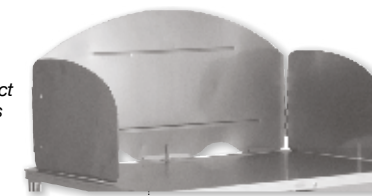

SILVER  
ACMSTORAGDEMW18

## COMBI IR GRILL NEW

If you are a keen campsite chef, the Combi IR Grill, is the ideal cooking essential for cooking up a storm. This 2-Burner cooker with infrared grill offers high heat output whilst remaining low on fuel consumption.

- 2 x 1.9KW, easy to clean burners for cooking several foods at once
- The 600W Infrared Grill saves 10% fuel and 90% on emissions
- Auto piezo ignition is quick to light and found built-in to the control valve for each burner
- Anti-slip feet
- Drip tray
- Individual burner controls
- Lid locks

**SIZE** ..... 57 x 34 x 13.5cm  
**PACKED** ..... 59.5 x 34.5 x 14.5cm  
**WEIGHT** ..... 5.2kg  
**CARTON QTY** ..... 1  
**STD ORDER QTY** . 1



ACNCOMBI H09Z05

## DINER NEW

If you have a large family to feed while camping, the Diner 3 burner cooker is ideal for cooking up the perfect meal to keep everyone happy!

- 3 x 1.9kw easy to clean burners for cooking several foods at once
- Auto piezo ignition is simple and quick to light and found built-in to the control valves
- Each burner has its own individual control
- A high quality burner grate
- Drip tray
- Lid locks
- Anti-slip feet

**SIZE** ..... 62 x 34 x 11.5cm  
**PACKED** ..... 67 x 34.5 x 13.5cm  
**WEIGHT** ..... 4.5kg  
**CARTON QTY** ..... 1  
**STD ORDER QTY** . 1



ACNDINER H09Z05

## GRIDDLE NEW

Whether you are preparing breakfast, lunch or dinner the Griddle is the ultimate flexible 2 burner & griddle family cooker.

- 2 x 1.9KW, easy to clean burners
- 1.3KW Grill
- Auto piezo ignition
- Individual burner controls
- Non-stick aluminium griddle plate
- Drip tray
- Lid locks
- Anti-slip feet

**SIZE** ..... 61 x 32 x 12cm  
**PACKED** ..... 67 x 34.5 x 14.5cm  
**WEIGHT** ..... 5.8kg  
**CARTON QTY** ..... 1  
**STD ORDER QTY** . 1



ACNGRIDDLEH09Z05

# ELECTRIC COOLERS HERO

## CHILL 28L NEW

Worried about keeping food and drink cool while camping? Well chill out because the Chill 28L electric cooler has you covered. This spacious cooler allows you to keep your food cool on outdoor adventures and family holidays.

- Up to 18-20°C below ambient temperature
- Holds one, 2 litre bottle standing and 47 cans
- Polyurethane foam insulation maintains cool temperatures and acts as a moisture control
- Self-regulating valve to control the temperature
- Built-in cable compartment
- Keeps cool for 2 hours after fully charged
- Includes a UK plug and car adapter

SIZE.....L46 x W31 x H43cm  
 PACKED.....L47 x W32 x H47cm  
 WEIGHT .....7.1kg  
 CARTON QTY.....1  
 STD ORDER QTY. 1



DEEP GREY  
ACNCOOLER3LSW32

## FROSTBITE 46L NEW

The biggest in our electric cooler range, the Frostbite, is extremely spacious and sure to keep all your food and drink chilled throughout your camping holiday.

- Up to 18-20°C below ambient temperature
- Holds two, 2 litre bottles standing and 62 cans
- Polyurethane foam insulation maintains cool temperatures and acts as a moisture control
- Self-regulating valve to control the temperature
- Extendable handle & built in wheels
- Two removable dividers
- Keeps cool for 2 hours after fully charged
- Includes a UK plug and car adapter

SIZE.....L54.5 x W41x H44.5cm  
 PACKED.....L58 x W44 x H44cm  
 WEIGHT .....10.1kg  
 CARTON QTY.....1  
 STD ORDER QTY. 1



DEEP GREY  
ACNCOOLER3LUW32

## GLACIER 18L NEW

A versatile electrical cooler. The Glacier may be small but it has incredible cooling power and energy saving performance in one. Featuring 18L of storage, the glacier allows you to keep your food cool on family holidays and adventures.

- Up to 18-20°C below ambient temperature
- Holds 14 cans
- Polyurethane foam insulation maintains cool temperatures and acts as a moisture control
- Self-regulating valve to control the temperature
- Uses as a cool box or a fridge
- Keeps cool for 2 hours after fully charged
- Includes a UK plug, EU and car adapter

SIZE.....L46 x W29 x H35cm  
 PACKED.....L51 x W33 x H39.5cm  
 WEIGHT .....5kg  
 CARTON QTY.....1  
 STD ORDER QTY. 1



Carry handle for easy transport!

DEEP GREY  
ACNCOOLER3LTW32

## NON-STICK MESS TINS (PAIR)

Perfect for lightweight adventurers. These non-stick mess tins sit neatly inside each other taking up very little room in your rucksack.

- Easy clean, non-stick coating.
- Folding handles with heat resistant grips
- Stack into each other for easy packaway
- Small mess tin: 1L / 16.2 x 13.4 x 5.5cm
- Large mess tin: 1.3L / 18.3 x 13.9 x 6cm



ACXCOOK009U09

**WEIGHT** ..... 360g  
**CARTON QTY** ..... 36  
**STD ORDER QTY.** 1

## NON-STICK 1-PERSON COOK KIT

Robust and durable, years of use with little or no maintenance. Fully nests together. One cup per person. Foldaway integral handles. Supplied in carry bag.

- 1 x 700ml pot / 1 x 900ml pot.
- 2 x pot lids.
- 1 x Ø14cm frying pan.
- 1 x plastic cup.

**WEIGHT** ..... 660g  
**CARTON QTY** ..... 10  
**STD ORDER QTY.** 1



ACXCOOK009U01

## NON-STICK 2-PERSON COOK KIT

Robust and durable, years of use with little or no maintenance. Fully nests together. One cup per person. Foldaway integral handles. Supplied in carry bag.

- 1 x 900ml Pot / 1 x 1400ml pot.
- 2 x pot lids.
- 1 x Ø16cm frying pan.
- 2 x plastic cups.

**WEIGHT** ..... 790g  
**CARTON QTY** ..... 10  
**STD ORDER QTY.** 1



ACXCOOK009U02

## NON-STICK 3-PERSON COOK KIT

Robust and durable, years of use with little or no maintenance. Fully nests together. One cup per person. Foldaway integral handles. Supplied in carry bag.

- 1 x 1200ml pot / 1 x 1600ml pot.
- 2 x pot lids.
- 1 x Ø17cm frying pan.
- 3 x plastic cups.

**WEIGHT** ..... 890g  
**CARTON QTY** ..... 1



ACXCOOK009U03

## NON-STICK 4-PERSON COOK KIT

Robust and durable, years of use with little or no maintenance. Fully nests together. One cup per person. Foldaway integral handles. Supplied in carry bag.

- 1 x 1400ml pot / 1 x 1800ml pot.
- 2 x pot lids.
- 1 x Ø18cm frying pan.
- 4 x plastic cups.

**WEIGHT** ..... 1.08kg  
**CARTON QTY** ..... 10  
**STD ORDER QTY.** 1



ACXCOOK009U05

## NON-STICK 8-PERSON COOK KIT

Robust and durable, years of use with little or no maintenance. Fully nests together. One cup per person. Foldaway integral handles. Supplied in carry bag.

- 1 x 1400ml pot / 1 x 2000ml pot
- 1 x 2600ml pot • 2 x pot lids.
- 1 x ø26cm frying pan.
- Frying pan handle.
- 8 x plastic cups.

**WEIGHT** ..... 2.08kg  
**CARTON QTY** ..... 6  
**STD ORDER QTY.** 1



ACXCOOK009U07

# COOKING

## ALUMINIUM COOK SET

The Aluminium Cook Set with kettle includes everything you need for your camping holiday.

- 1.3L kettle.
- Non-stick frying pan 20cm.
- 1.5L pot 17cm.
- 2L pot 18cm.
- 3L pot 20cm.
- Removeable pot handle.

**WEIGHT** ..... 950g  
**CARTON QTY** ..... 12  
**STD ORDER QTY** . 1



## STAINLESS STEEL KETTLE UPDATED

Stylish, stainless steel whistling kettles with removable lid and folding handle.

- New green colour
- Tough and durable stainless steel.
- Whistling kettle.
- Removable lid.
- Durable folding, heat resistant handle.
- Pull/push lever to open/close spout.

### 1.6 LITRES

**SIZE** ..... WØ16.5 x H14.5cm  
**WEIGHT** ..... 360g  
**CARTON QTY** ..... 12  
**STD ORDER QTY** . 1

- ACXKETTLE230W18
- ACXKETTLE230W24

### 2 LITRES

**SIZE** ..... WØ18.5 x H17cm  
**WEIGHT** ..... 405g  
**CARTON QTY** ..... 12  
**STD ORDER QTY** . 1

- ACXKETTLE231W18
- ACXKETTLE231W24



# TABLEWARE

## FAMILY CUTLERY SET

*The Vango Family Cutlery Set is a perfect addition to your camping essentials. The set is held neatly in its own roll up case for easy use and transport.*

- Stainless steel - tough and durable.
- 4 x knives, 4 x forks, 4 x spoons.
- Storage bag.

**SIZE** ..... L43 x W25cm

**PACKED** ..... L25 x WØ7cm

**WEIGHT** ..... 430g

**CARTON QTY** ..... 20

**STD ORDER QTY** . 1



## ACRYLIC TUMBLERS x4

*Set of four acrylic tumblers. Strong but lightweight. Perfect for the picnic basket or barbecues at home or on the road.*

- Strong and lightweight.
- Not suitable for microwaves or dishwashers.
- 450ml capacity.

**WEIGHT** ..... 370g (97g each)

**CARTON QTY** ..... 24

**STD ORDER QTY** . 24



## ACRYLIC WINE GLASSES x4

*Set of four acrylic glasses. Strong but lightweight. Perfect for the picnic basket or barbecues at home or on the road.*

- Strong and lightweight.
- Not suitable for microwaves or dishwashers.
- 325ml capacity.

**WEIGHT** ..... 400g (100g each)

**CARTON QTY** ..... 12

**STD ORDER QTY** . 12



# BAMBOO RANGE

- Safe to clean in the dishwasher.
- Food safe FDA and LFGB.
- Designed in modern colours and patterns to compliment your tent.
- Materials meet and exceed the European REACH standard, ensuring safe use.
- Made from sustainable and Eco friendly materials.

## BAMBOO MUG 350ML

Enjoy a hot chocolate while watching the stars after a day in the outdoors, with the new Vango Bamboo Mug. These mugs are highly durable to the outdoor elements and are also eco-friendly and sustainable, ideal for all of your upcoming camping trips, short or long.

SIZE..... WØ8 x H10cm  
 CARTON QTY..... CDU of 12  
 STD ORDER QTY. 1



GREEN  
ACMBAMBOO3JNZ35



COFFEE CUP PRINT  
ACMBAMBOO3JNZ40



## BAMBOO BOWL 14cm

The Vango Bamboo Bowl not only comes in a modern, stylish pattern, but it is also extremely durable to the outdoor elements. Featuring eco-friendly and sustainable materials, your kitchen needs will be taken care of, while still being kind to the environment.

SIZE..... WØ14cm x H6.5cm  
 CARTON QTY..... CDU of 12  
 STD ORDER QTY. 1



COFFEE CUP PRINT  
ACMBAMBOO3JOZ40



GREEN  
ACMBAMBOO3JOZ35

## BAMBOO DESSERT PLATE 20cm

Enjoy your dessert while staying eco-friendly with the new Vango Bamboo Dessert Plate. Featuring fresh new colours and gaining REACH approval, this plate is the ultimate camping essential for all of your tasty treats.

SIZE..... WØ20cm x H1.4cm  
 CARTON QTY..... CDU of 12  
 STD ORDER QTY. 1



GREEN  
ACMBAMBOO3JPZ35

COFFEE CUP PRINT  
ACMBAMBOO3JPZ40

## BAMBOO DINNER PLATE 28cm

Stay stylish on the campsite with Vango's new Bamboo dinner plate, ideal for all your camping meals. The sustainable, eco-friendly material combined with a modern, fun pattern makes it the ultimate in camping essentials. The Bamboo dinner plate is also REACH approved and extremely durable to the outdoors!

SIZE..... WØ28cm x H2cm  
 CARTON QTY..... CDU of 12  
 STD ORDER QTY. 1



COFFEE CUP PRINT  
ACMBAMBOO3JOZ40

GREEN  
ACMBAMBOO3JOZ35

## BAMBOO COFFEE CUP 470ML

There's nothing better than waking up in the outdoors to a mug of hot tea or coffee! The Vango Bamboo Coffee Cup is perfect for taking on all of your camping trips for your daily morning fix or even the journey to your destination.

SIZE ..... WØ9 x H13cm  
 CARTON QTY ..... 36  
 STD ORDER QTY .1



GREEN  
 ACMBAMBOO3JRZ35



COFFEE CUP PRINT  
 ACMBAMBOO3JRZ35

## BAMBOO KID'S SET

The kids will love this NEW addition to the Vango range. Featuring ECO friendly bamboo material with fun animal pattern, the Kid's Set is lightweight and durable, perfect for all those camping trips away with the family.

- Set contains:  
 Plate Ø23cm / bowl Ø12cm / cup Ø7.5cm  
 spoon / fork

WEIGHT ..... 365g  
 CARTON QTY ..... 8  
 STD ORDER QTY .1



GREEN  
 ACMBAMBOO3JTZ64

## BAMBOO 2-PERSON SET

The Vango bamboo 8-piece set is made from eco-friendly biodegradable bamboo. Dishwasher friendly, hardwearing and easy to clean this addition to the Vango range lets you enjoy dining outdoors in style.

- 2 x large plates Ø28cm.
- 2 x small plates Ø20cm.
- 2 x bowls Ø14cm.
- 2 x mugs Ø8 x 10cm.

WEIGHT ..... 1.30kg  
 CARTON QTY ..... 4  
 STD ORDER QTY .1



COFFEE CUP PRINT  
 ACMBAMBOO3JWZ40



GREEN  
 ACMBAMBOO3JVZ35

## BAMBOO PITCHER & CUPS SET

Ideal for family meals, the Vango Bamboo Pitcher & Cups Set features highly durable and sustainable materials. This modern set is also dishwasher safe and REACH approved, making it perfect for on the campsite or in the garden at home.

SIZE ..... WØ17.5 x H22.8cm (pitcher)  
 WØ7.5 x H11cm (cups)  
 WEIGHT ..... 750g  
 CARTON QTY ..... 12  
 STD ORDER QTY .1



COFFEE CUP PRINT  
 ACMBAMBOO3JUJZ40

## BAMBOO 4-PERSON SET

The Vango bamboo 16-piece set is made from eco-friendly biodegradable bamboo. Dishwasher friendly, hardwearing and easy to clean this addition to the Vango range lets you enjoy dining outdoors in style.

- 4 x large plates Ø28cm.
- 4 x small plates Ø20cm.
- 4 x bowls Ø14cm.
- 4 x mugs Ø8 x 10cm.

WEIGHT ..... 2.60kg  
 CARTON QTY ..... 4  
 STD ORDER QTY .1



COFFEE CUP PRINT  
 ACMBAMBOO3JWZ40



GREEN  
 ACMBAMBOO3JVZ35



# WATER CARRIERS

## FOLDABLE WATER CARRIER 8L

When you need to store and transport water on your travels the Vango water Carriers are perfect. The 8L Foldable, folds down when not in use to pack away neatly and easily.

- PE body - strong and durable
- Compact, folds away when not in use
- Valve - for easy pouring.
- Carry handle

**SIZE** ..... L22 x W26 x H20cm  
**WEIGHT** ..... 198g  
**CARTON QTY** ..... 30  
**STD ORDER QTY** .1



ACXWATERC3OIZ01

## SQUARE WATER CARRIER 15L

The Square Water Carrier is perfect for transporting and storing water whilst on your travels. Holding up to 15 litres which is great for camping trips with friends.

- PE body - strong and durable
- Compact, folds away when not in use
- Valve - for easy pouring.
- Carry handle

**SIZE** ..... L25 x W25 x H30cm  
**WEIGHT** ..... 300g  
**CARTON QTY** ..... 20  
**STD ORDER QTY** .1



ACXLIGHTS3JYW24

## EXPANDABLE WATER CARRIER 12L

When you need to store and transport water on your travels the Vango water Carriers are perfect. The Expandable folds down when not in use to pack away neatly and easily.

- PE body - strong and durable
- Compact, folds away when not in use
- Valve - for easy pouring.
- Carry handle

**SIZE** ..... L26 x W8 x H41cm  
**WEIGHT** ..... 300g  
**CARTON QTY** ..... 20  
**STD ORDER QTY** .1



ACXWATERC3OCZ01

## JERRY CAN 10L

This Vango 10 litre heavy duty Jerrycan is perfect for your camping holidays. Fill up at the start of your trip to keep a good supply of drinking and washing up water at your tent.

- Made from polyurethane.
- Lockable pouring spout.

**SIZE** ..... L28 x W22 x H32cm  
**WEIGHT** ..... 300g  
**CARTON QTY** ..... 6  
**STD ORDER QTY** .1



ACXWATERC3OPZ01

## WATER TANK 25L NEW

The Vango 25L water tank eliminates heavy lifting when collecting water for your campsite. With a volume of 25 litres, and a built-in set of wheels this water tank takes the strain out of moving water.

- 25L capacity
- Hi density polyethylene construction
- Flexible pipe & tap system
- Separate inlet/outlet caps
- Handle and Large Wheels

**SIZE** ..... L80 x W37 x H23cm  
**WEIGHT** ..... 3.2kg  
**CARTON QTY** ..... 1  
**STD ORDER QTY** ...1



ACNWTRTNKG10RE4

## WATER TANK 40L NEW

The Vango 40L water tank eliminates heavy lifting when collecting water for your campsite. With a volume of 40 litres, and a built-in set of wheels this water tank takes the strain out of moving water.

- 40L capacity
- Hi density polyethylene construction
- Flexible pipe & tap system
- Separate inlet/outlet caps
- Handle and Large Wheels

**SIZE** ..... L80 x W37 x H23cm  
**WEIGHT** ..... 4.2kg  
**CARTON QTY** ..... 1  
**STD ORDER QTY** ...1



ACNWTRTNKG10RE7

# TRAVEL ESSENTIALS

## CLOTHES DRYER

*Drying clothes whilst camping has never been easier than with this lightweight, three-armed Vango Clothes Dryer.*

- 3 Arm Dryer - plenty of space to dry your clothes.
- Aluminium frame - lightweight and strong.
- Locking frame - locks in to place.
- Ring and pin system and pegs included.
- Handled carry bag.

**SIZE** ..... W134 x D134 x H143cm  
**FOLDED** ..... W22 x D13 x H87cm  
**WEIGHT** ..... 1.82kg  
**MAX LOAD** ..... 22kg / 3st 6lbs  
**CARTON QTY** ..... 1  
**STD ORDER QTY** .1

SILVER  
ACMSTORAG0TTW18



## MULTI-PURPOSE ROPE

*The Vango Multi-Purpose Rope is a strong nylon rope with many uses. With so many practical applications, from caravanning to technical expeditions, it is always handy to have a reliable rope to hand for any eventuality - after all, you never know when you might need it ...*

**NOT SUITABLE FOR CLIMBING**

**SIZE** ..... 15m x Ø9mm  
**WEIGHT** ..... 520g  
**CARTON QTY** ..... 20  
**STD ORDER QTY** .1

ACXROPEM43Z01



## TRANSIT

*With the Vango Transit Trolley, struggling to carry all your camping equipment and belongings to your pitching spot is a thing of the past. A flipback trolley which can hold up to 70 kg, with the Transit you can effortlessly wheel your belongings to the desired location.*

- Alloy frame - lightweight and strong.
- 2 stage telescopic handle.
- Elastic tie round included - to keep your belongings secure.
- Large wheels for strength and maximum weight loading.
- Fold's flat for easy storing and transport.

**SIZE** ..... W41 x D39 x H101cm  
**FOLDED** ..... W65 x D5.5 x H39cm  
**WEIGHT** ..... 3.0kg  
**MAX LOAD** ..... 70kg / 11st  
**CARTON QTY** ..... 6  
**STD ORDER QTY** .1

SILVER  
ACMSTORAGT52W18



# TOILETS NEW

## THRONE 12L

The Vango Throne 12L is ideal for camping if you want to avoid mid-night trips to the campsite toilets. A high-density construction and ergonomic seat make it strong and durable, yet comfortable to use. The piston pump, which allows for 3 directions of flush, improves the efficiency of the flush as well as the cleanliness of the toilet. A detachable waste tank makes for easy cleaning

- Hi Density Polyethylene Construction
- 12L Top Fresh Water Tank
- 12L Bottom Waste Tank
- Pressure Release Button
- Detachable Waste Tank
- Piston Pump
- Ergonomic Seat
- Slide Valve
- Side Latches
- Built-in Carry Handle
- Storage bag
- Maximum Loading Weight: 200kg / 31 stone

**SIZE** ..... L41.5 x W36.5 x H30cm

**PACKED** ..... L42 x W37.5 x H31.5cm

**WEIGHT** ..... 4.5kg

**CARTON QTY** ..... 1

**STD ORDER QTY** . 1



ACNTHRONEG10REA

## THRONE 21L

The Vango Throne 21L is ideal for camping if you want to avoid mid-night trips to the campsite toilets. A high-density construction and ergonomic seat make it strong and durable, yet comfortable to use. The piston pump, which allows for 3 directions of flush, improves the efficiency of the flush as well as the cleanliness of the toilet. A detachable waste tank makes for easy cleaning

- Hi Density Polyethylene Construction
- 12L Top Fresh Water Tank
- 21L Bottom Waste Tank
- Waste tank level indicator (Red = full, green = empty)
- Maximum Loading Weight: 200kg / 31 stone
- Pressure Release Button
- Detachable Waste Tank
- Piston Pump
- Ergonomic Seat
- Slide Valve
- Side Latches
- Built-in Carry Handle
- Storage bag
- Maximum Loading Weight: 200kg / 31 stone

**SIZE** ..... L41.5 x W36.5 x H42cm

**PACKED** ..... L42 x W37.7 x H43.5cm

**WEIGHT** ..... 5.1kg

**CARTON QTY** ..... 1

**STD ORDER QTY** . 1



ACNTHRONEG10REB

## VOLTAIC CONVERSION LEADS

The Vango Socket Conversion Lead will allow you to use a household item on your camping trip, with the use of a mains cable.

SIZE ..... 0.3m  
 CARTON QTY ..... 60  
 STD ORDER QTY . 10

**EU**



ACNVOLTAI3MJZ05

**UK**



ACNVOLTAI3MFZ05

## VOLTAIC UK SOCKET CONVERSION LEAD

The Vango UK Socket Conversion Lead will allow you to use a household item (with a 3 pin UK plug) on your camping trip, with the use of a mains cable.

SIZE ..... 0.3m  
 CARTON QTY ..... 60  
 STD ORDER QTY . 10



ACNVOLTAI3MLZ05

## VOLTAIC 3-WAY DISTRIBUTION ADAPTOR

The Voltaic 3 Way Distribution Adaptor offers 3 weather protected mains outlets allowing you make use of the power for more than one electric compliance at a time.

SIZE ..... cm  
 CARTON QTY ..... 20  
 STD ORDER QTY . 5



ACNVOLTAI3MIZ05

## VOLTAIC MAINS CABLE

The Vango Voltaic Mains Cable is designed to go from the campsite electric point to your tent, providing you with mains electric and making access to power easier

**10M**



ACNVOLTAI3MGZ05

**25M**



ACNVOLTAI3MQZ05

CARTON QTY ..... 10  
 STD ORDER QTY . 1

CARTON QTY ..... 4  
 STD ORDER QTY . 1

## VOLTAIC ROLL AWAY

The Voltaic Roll Away provides 15 metres of roll away cable allowing you freedom for positioning your mains electric. Offering up 3 sockets and 2 USB ports, along with an LED light, means you can supply power to multiple items at a time. Includes stabilisers to improve stability.

- 3 UK plug sockets for providing power to multiple items at once
- 2 USB ports providing additional power options
- Find the Voltaic Roll Away with ease in the dark with the bright LED light
- 15m, 1.5mm roll away cable
- 2 x stabilisers to provide stability when multiple sockets are in use

SIZE ..... L28 x W17 x H35cm  
 WEIGHT ..... 3.5kg  
 CARTON QTY ..... 4  
 STD ORDER QTY . 1



ACNVOLTAI3MKZ05

# LANTERNS

## STAR 85

*This compact ambient lantern is ideal for festivals, family camping or even for providing soft light around the table. Its fun design converts it from table top to hanging lantern in seconds, perfect when on the move.*

- Can be used as a table top or a hanging lantern.
- Hanging hook rotates 360°.
- Warm, ambient light effect.
- 2 lighting options:  
Low: 40 lumens / High: 85 lumens
- Powered by 4 x AA batteries (not included).
- Runtime:  
Low: 32 hours / High: 12 hours (dependent on battery quality).



HERBAL  
ACMLANTRN3JMRU4

RIVER  
ACMLANTRN3JMZ63

SIZE ..... WØ9.5 x H14cm  
 WEIGHT ..... 140g  
 CARTON QTY ..... 24  
 STD ORDER QTY. 1

## GALAXY RECHARGEABLE 60

*Great for people on the move who are looking for bright and effective lighting. It is equipped with two lighting modes so you can adapt the lighting to your specific needs and it can be effortlessly wound up to recharge the batteries.*

- Folding, easy-grip handle
- 36LED - lights up to 60 lumens
- Built-in rechargeable battery
- Built-in wind-up charging:  
2 mins of winding = 25 mins of light
- Multi-mode light switch
- Car adaptor included
- UK plug & EU adaptor included
- Built-in circuit protection

SIZE ..... WØ14 x H25cm  
 WEIGHT ..... 620g  
 CARTON QTY ..... 6  
 STD ORDER QTY. 1



HERBAL  
ACMLANTRN3JJRU4

## GALAXY 150

*A great all-round camping lantern. Powered by 3 D batteries (not included), perfect for use during longer camping trips, whilst its handy carry handle increases portability.*

- Folding, easy-grip handle.
- 18LED - Lights up to 150 lumens.
- Powered by 3 x D batteries (not included)
- Run time : 15 hours (dependent on battery quality).

SIZE ..... WØ14 x H25cm  
 WEIGHT ..... 480g  
 CARTON QTY ..... 6  
 STD ORDER QTY. 1



HERBAL  
ACMLANTRN3JJRU4

## GALAXY ECO RECHARGEABLE 60

*Great for people on the move who are looking for bright and effective lighting. Equipped with two lighting modes so you can adapt the lighting to your specific needs and it can be wound up or use the solar panel to recharge the batteries.*

- Folding, easy-grip handle with hanging hook
- Solar panel
- 36LED - lights up to 60 lumens
- Built-in rechargeable battery
- Built-in wind-up charging:  
2 mins of winding = 25 mins of light
- Multi-mode light switch
- Car adaptor included
- UK plug & EU adaptor included
- Built-in circuit protection

SIZE ..... WØ14 x H25cm  
 WEIGHT ..... 640g  
 CARTON QTY ..... 6  
 STD ORDER QTY. 1



HERBAL  
ACMLANTRN3JKRU4

# LANTERNS

## ROCKET RECHARGEABLE 120

A high quality camping lantern, utilising high-strength CREE LEDs to produce a bright light - either at 40 or 120 lumens. Includes a built in rechargeable lithium ion battery which can be charged using your car adaptor so you will never have to worry about buying batteries again.

- CREE LED provides high quality light.
- Built-in rechargeable 1600 mAh lithium ion battery.
- Charge time: 2 1/2 hours.
- 2 settings: **Low:** 40 lumens / **High:** 120 lumens.
- Run time: **Low:** 16 hours / **High:** 6 hours.
- Intelligent power indicator.
- Car adaptor included.
- Charge your phone or tablet using the USB port.
- Carry handle and hanging hook.

**SIZE** ..... WØ8 x H18.8cm  
**WEIGHT** ..... 200g  
**CARTON QTY** ..... 1



## ROCKET BLUETOOTH 120

A high quality, Bluetooth compatible lantern with built-in speaker, utilising high-strength CREE LEDs to produce a bright light either at 40 or 120 lumens. The lantern includes a built in rechargeable battery which can be charged using your car adaptor.

- CREE LED provides high quality light.
- Bluetooth with built-in wireless speaker - range 8m.
- Built-in rechargeable 1600 mAh lithium ion battery.
- Charge time: 2 1/2 hours.
- 2 settings:  
**Low:** 40 lumens / **High:** 120 lumens.
- Run time:  
**Low:** 16 hours / **High:** 6 hours .
- Intelligent power indicator.
- Car adaptor included.
- Charge your phone or tablet using the USB port.
- Carry handle and hanging hook.

**SIZE** ..... WØ8 x H18.8cm  
**WEIGHT** ..... 200g  
**CARTON QTY** ..... 1



## SPECTRUM 250

The most versatile of our camping lanterns, the Spectrum gives a warm lighting effect while producing a powerful 250 Lumens of light using high quality Nichia LEDs. These LEDs enable you to select one of 4 separate lighting effects: natural, cool, warm, or candle.

- Powerful Nichia LED's provide high quality light.
- Powered by 4 x AA batteries (not included).
- Lights up to 250 lumens.
- 4 lighting effects :  
**Natural White / Cool White / Warm White Candle light**
- Run time: 10 - 45 hours (dependent on battery quality).
- Intelligent power indicator.
- Rubberised handle and body - anti-slip, anti-shock.
- Water resistant case.
- Removable cap - can be used as a downlight, using the hanging hook on base.

**SIZE** ..... WØ5.8 x H13cm  
**WEIGHT** ..... 245g  
**CARTON QTY** ..... 1



## SPECTRUM 380

The most versatile of our camping lanterns, the Spectrum produces a powerful 380 lumens of light using high quality Nichia LEDs. These LEDs enable you to select one of 4 separate lighting effects: natural, cool, warm, or candle.

- Powerful Nichia LED's provide high quality light.
- Powered by 6 x AA batteries (not included).
- Lights up to 380 lumens.
- 4 lighting effects :  
**Natural White / Cool White / Warm White Candle light**
- Run time: 12 - 80 hours (dependent on battery quality).
- Intelligent power indicator.
- Rubberised handle and body - anti-slip, anti-shock.
- Water resistant case.
- Removable cap - can be used as a downlight, using the hanging hook on base.

**SIZE** ..... WØ7.4 x H15.8cm  
**WEIGHT** ..... 260g  
**CARTON QTY** ..... 1



## SPECTRUM 530

The most versatile of our camping lanterns, the Spectrum produces a powerful 530 lumens of light using high quality Nichia LEDs. These LEDs enable you to select one of 4 separate lighting effects: natural, cool, warm, or candle.

- Powerful Nichia LED's provide high quality light.
- Powered by 3 x D batteries (not included).
- Lights up to 530 lumens.
- 4 lighting effects :  
**Natural White / Cool White / Warm White Candle light**
- Run time: 17 - 190 hours (dependent on battery quality).
- Intelligent power indicator.
- Rubberised handle and body - anti-slip, anti-shock.
- Water resistant case.
- Removable cap - can be used as a downlight, using the hanging hook on base.

**SIZE** ..... WØ12.2 x H24cm  
**WEIGHT** ..... 420g  
**CARTON QTY** ..... 1



# LIGHTING

## LIGHT DISC

Perfect for lighting bedrooms and ideal for providing comfort for small children. A great reading light and can light up a social area inside your tent.

- Provides 75 lumens of light.
- 48LED - strong, bright light
- Multi-mode light switch
- Hanging hook
- Battery operated 4 x AA (Not included)

**SIZE**..... WØ14.5 x H2cm  
**WEIGHT** ..... 150g  
**CARTON QTY**..... 72  
**STD ORDER QTY**. 1



## GENIE 100 LAMP NEW

New for 2018, the Genie 100 Rechargeable Lamp will add a homely feel to your outdoor escape. Producing 100 lumens, and offering 3 different lighting modes it provides an array of warm light at the flick of a switch - just like your lights at home.

- Switch the lamp on by gently pulling the on/off cord
- 3 light modes
- 100 lumens of light
- Built-in rechargeable 3.7V/1800mAh lithium battery with USB charging cable
- 4 hours of runtime when fully charged
- Charge for 4 hours to get maximum usage

**SIZE**..... WØ16.5 x H26cm  
**WEIGHT** ..... 465g  
**CARTON QTY**..... 10  
**STD ORDER QTY**. 1



# SUNBEAM

## SUNBEAM STARTER KIT

Add more light to your outdoor home with the Sunbeam Starter Kit. Offering 2 lights, producing 450 lumens, the Sunbeam provides a warm light and comes equipped with a switch, just like your lights at home. The LED lights are impact resistant and versatile, wherever you want to place them.

- On/off switch - for manual control.
- Provides 450 lumens of warm light per light.
- UK/EU plug included.
- 2 x 5m extension cables included.
- 10 x loop/hook fastening straps included for attaching the lights to your tent or awning.

**CARTON QTY..... 10**  
**STD ORDER QTY. 1**



ACXLIGHTS3JZW24

## SUNBEAM EXTENSION KIT

Add more light to your outdoor home with the Sunbeam Extension Kit. Producing 450 lumens, the Sunbeam provides a warm light and comes equipped with a switch, just like your lights at home. The LED lights are impact resistant and versatile, wherever you want to place them.

- On/off switch - for manual control.
- Provides 450 lumens of warm light.
- 2 x 5m extension cables included.
- 5 x loop/hook fastening straps included for attaching the lights to your tent or awning.

**CARTON QTY..... 10**  
**STD ORDER QTY. 1**



ACXLIGHTS3JW24

## SUNBEAM LIGHT SYSTEM CORE

The Sunbeam is the ultimate light system for tents and awnings. Offering 4 lights, producing 450 lumens, the Sunbeam provides a warm light and comes equipped with a switch, just like your lights at home, and a remote control for easy use. The LED lights are impact resistant and versatile, wherever you want to place them.

- 4 x on/off switches - for individual manual control.
- Remote control - for easy use.
- Provides 450 lumens of warm light per light.
- UK/EU plug included.
- DC adaptor - system can be powered from your car.
- 2 x 2.4m and 2 x 5m extension cables included.
- 3-way splitter - lights can be used in different rooms.
- 10 x short and 10 x long, loop/hook fastening straps included for attaching the lights to your tent or awning.
- Handled carry bag.

**CARTON QTY..... 10**  
**STD ORDER QTY. 1**



ACXLIGHTS3JOW24





## ESSENTIALS

### TECHNICAL

Whether it's a super bright headtorch or a backup firestarter, our Vango Essentials range has it all.

Our range of technical essentials reflect our ethos of being great value, feature packed and user orientated. Whether you are looking for a stove for a youth group or a headtorch that out performs even the most established competitors, our range staples and new additions will have the ideal kit to meet your needs.

# HEAD TORCHES

## VOLT

The Volt headtorch produces up to 100 lumens from its array of LEDs, utilising a collimator lens to provide long distance light projection whilst maintaining soft peripheral light. Compact and versatile, the Volt headtorch can be easily removed from the headband and clipped onto your helmet, clothes or rucksack, providing an adaptable light-solution to all your outdoor needs. away neatly and easily.

- 100 lumen output on the high setting
- Comfortable, elasticated headband keeps the torch secure on the users head
- Torch can be detached from the headband and clipped to tent pockets or rucksack harness straps
- Head unit can be adjusted up and down
- Premium CREE LED light provides a brilliant white light
- Collimator Lens - Provides long distance light projection whilst maintaining soft peripheral light
- 3x Energizer AAA batteries included



ACNVOLT G38Z05

**WEIGHT** ..... 86g  
**CARTON QTY** ..... 6  
**STD ORDER QTY** .6

## FLUX

The Flux headtorch produces up to 120 lumens from its array of LEDs, utilising a collimator lens to provide long distance light projection whilst maintaining soft peripheral light. Compact and versatile, the Flux headtorch can be easily removed from the headband and clipped onto your helmet, clothes or rucksack, providing an adaptable light-solution to all your outdoor needs.

- 120 lumen output on the high setting
- Collimator Lens - Provides long distance light projection whilst maintaining soft peripheral light
- Premium CREE LED light provides a brilliant white light
- Front red LED to help preserve night vision
- Comfortable, elasticated headband keeps the torch secure on the users head
- Torch can be detached from the headband and clipped to tent pockets or rucksack harness straps
- Head unit can be adjusted up and down
- 3x Energizer AAA batteries included.



ACNFLUX G44Z05

**WEIGHT** ..... 88g  
**CARTON QTY** ..... 6  
**STD ORDER QTY** .6

## PHOTON

The Photon headtorch produces up to 150 lumens from its array of LEDs, utilising a collimator lens to provide long distance light projection whilst maintaining soft peripheral light. Compact and versatile, the Photon headtorch can be easily removed from the headband and clipped onto your helmet, clothes or rucksack, providing an adaptable light-solution to all your outdoor needs.

- 150 lumen output on the high setting
- Premium CREE LED light provides a brilliant white light
- Collimator Lens - Provides long distance light projection whilst maintaining soft peripheral light
- Red rear LED for increased visibility. Flash and steady modes
- Front red LED to help preserve night vision.
- Comfortable, elasticated headband keeps the torch secure on the users head
- Torch can be detached from the headband and clipped to tent pockets or rucksack harness straps
- Rechargeable 1200mAh Li-Polymer Battery. Usb rechargeable, cable included
- Head unit can be adjusted up and down



ACNPHOTONG47Z05

**WEIGHT** ..... 83g  
**CARTON QTY** ..... 6  
**STD ORDER QTY** .6

# WALKING POLES

## PICO ACXWALKPO0PPZ60

The Pico walking pole designed with comfort and durability in mind. Lightweight aluminium poles adjusted with QuickLock closures for increased ergonomic durability. The Pico features a comfortable foam handle and tungsten tip.

- HANDLE** foam - standard length
- LENGTH** 65-135cm
- LOCKING MECHANISM** QuickLock
- MATERIAL** Alloy 6061
- BASKET** included
- STOPPER** included
- TIP** Tungsten
- WEIGHT** 268g
- CARTON QTY** 1



## INCA ACXWALKPO0PQZ52

The Inca walking pole designed with comfort and durability in mind. Lightweight aluminium poles adjusted with QuickLock closures for increased ergonomic durability. The Inca features an extended comfortable foam handle and tungsten tip.

- HANDLE** foam - extended length
- LENGTH** 65-135cm
- LOCKING MECHANISM** QuickLock
- MATERIAL** Alloy 6061
- BASKET** included
- STOPPER** included
- TIP** Tungsten
- WEIGHT** 273g
- CARTON QTY** 1



## CAMINO ACXWALKPO0PRZ61

The Camino walking pole designed with comfort and durability in mind. Lightweight aluminium poles adjusted with QuickLock closures for increased ergonomic durability. The Camino features a comfortable foam handle with integrated anti-shock and tungsten tip.

- HANDLE** foam - standard length
- LENGTH** 67-135cm
- LOCKING MECHANISM** QuickLock
- MATERIAL** Alloy 7075
- SHOCK ABSORBER** Yes - in handle
- BASKET** included
- STOPPER** included
- TIP** Tungsten
- WEIGHT** 268g
- CARTON QTY** 1



## POLE BASKETS x2

Designed to replace baskets which have been lost or damaged. Fits all Vango walking poles.

- CARTON QTY** 1
- ACXWALKPO0PNZ30



## POLE STOPPER x2

Designed to replace stoppers which have been lost or damaged. Fits all Vango walking poles.

- CARTON QTY** 1
- ACXWALKPO0POZ30



# RUCKSACK ESSENTIALS

## HYDRANT 2L

RUMHYPACKZ01Z01

The Vango Hydrant Pack is ideal for those on the go, providing easy access to water and with securely locking sealable closure. The Hydrant Pack is made from strong, durable TPU material which is BPA free, no chance of leaks or wet kit. While the oversized full top opening ensures it is easy to clean.

- Fits the back panel of any pack.
- TPU (Thermo Plastic Polyurethane) is strong and abrasion resistant.
- BPA free – (Bisphenol A).
- Quick-release hose and shut-off valve make drinking and re-filling easy.

**CAPACITY** 2 litres  
**WEIGHT** 140g  
**STD ORDER QTY** 1



## DRY BAG

The Vango dry bag is perfect for lining your rucksack on trips where it is likely to get wet, and keeping items separated and dry inside larger bags. The roll top closure system effectively seals the bag against any encroaching water, making it ideal for cycling, kayaking and wet weather trekking activities.

- Lightweight, high quality fasteners with Hypalon webbing.
- Roll top dry bag - expel excess air and roll 3 times for a sealed, water tight bag.

**30**  
**CAPACITY** 30 litres  
**SIZE** H50 x WØ29CM  
**WEIGHT** 80g  
**STD ORDER QTY** 5



**ORANGE**  
RUMDRYBAGO07046

## DRY BAG SET

RUMDRYBAGAS5Z23

The Vango Dry Bag Set offers a variety of sizes to protect all your essentials when trekking, cycling, kayaking, climbing, commuting or travelling. An indispensable companion for the wet and wild outdoors!

- Lightweight, high quality fasteners with Hypalon webbing.
- Roll top dry bag - expel excess air and roll 3 times for a sealed, water tight bag.



**60**  
**CAPACITY** 60 litres  
**SIZE** H70 x WØ33CM  
**WEIGHT** 100g  
**STD ORDER QTY** 5



**GREEN**  
RUMDRYBAGG07065

### SMALL

**CAPACITY** 2 litres  
**SIZE** H28 x W24cm  
**WEIGHT** 30g

### LARGE

**CAPACITY** 16 litres  
**SIZE** H32 x WØ25cm  
**WEIGHT** 55g

### MEDIUM

**CAPACITY** 6 litres  
**SIZE** H30 x WØ16cm  
**WEIGHT** 38g

**STD ORDER QTY** 5

## RAIN COVER

Lightweight protection from the rain for your rucksack. The perfect companion on your adventures.

- Polyester PU coated body.
- Bright orange with silver logo.



**SMALL** RUMRAINCOV07CL2  
**SIZED FOR 25-36 LITRE PACKS**  
**STD ORDER QTY** 10

**MEDIUM** RUMRAINCOV07CL3  
**SIZED FOR 40-55 LITRE PACKS**  
**STD ORDER QTY** 10

**LARGE** RUMRAINCOV07B57  
**SIZED FOR 60+ LITRE PACKS**  
**STD ORDER QTY** 10

## MESH BAG SET

RUMMESHBAZ03Z05

Keep your equipment tidy and organized with the multi-color mesh set.

**WEIGHT** 230g  
**STD ORDER QTY** 5



## UNIVERSAL HIP POUCH



RUNACCESSH79Z05

The ideal accessory to any of our trekking rucksacks, just slide it onto the hip belt and you have additional small storage pockets.

**WEIGHT** 100g  
**STD ORDER QTY** 5



# FLASKS & MUGS

## VACUUM FLASKS

Keep hot drinks hot and cold drinks refreshingly cool. Comes with an easy to use screw top. Ideal for camping, picnics or keeping in the car for long journeys. Not suitable for dishwasher.

- Double walled, stainless steel construction.
- Plastic rimmed/lined drinking cup
- Screw top with pouring spout.

STYLE	DIMENSIONS	WEIGHT	CARTON QTY	SKU
350ML	WØ7.3 x H21.5cm	243g	6	ACNFLASKG29F13
500ML	WØ7.3 x H26cm	289g	6	ACNFLASKG29F02
750ML	WØ9 x H27.5cm	466g	6	ACNFLASKG29F14
1L	WØ9 x H30.5cm	542g	6	ACNFLASKG29F05



## MUG 230ML

This stainless steel mug with a plastic handle is strong and durable for outdoor use. The stainless steel double wall will keep your hot drink or soup well insulated. Not suitable for dishwasher.

- Double-walled, stainless steel construction.
- Plastic lid with drinking channel.
- Shaped, heat resistant carry handle.

SIZE ..... WØ8.5 x H9.5cm  
 WEIGHT ..... 85g  
 CARTON QTY ..... 12



GUNMETAL  
ACNFLASKG29F16

## MUG 450ML

This stainless steel mug with a plastic lining and handle is strong and durable for outdoor use. The cover will keep your hot drink or soup well insulated for longer. Not suitable for dishwasher.

- Stainless steel, plastic lined construction.
- Plastic lid with drinking channel.
- Shaped, heat resistant carry handle.

SIZE ..... WØ12 x H16.5cm  
 WEIGHT ..... 185g  
 CARTON QTY ..... 6



GUNMETAL  
ACNFLASKG29F17

## STAINLESS STEEL MUG 450ML

This stainless steel mug with plastic handle is strong and durable for outdoor use. The stainless steel double wall and cover will keep your hot drink or soup well insulated for longer. Not suitable for dishwasher.

- Double-walled, stainless steel construction.
- Plastic lid with drinking channel.
- Shaped, heat resistant carry handle.

SIZE ..... WØ13 x H18cm  
 WEIGHT ..... 216g  
 CARTON QTY ..... 6



GUNMETAL  
ACNFLASKG29F12

# GAS STOVES & ACCESSORIES

## COMPACT STOVE ACXSTOVEDAJZ36

The Compact Stove is an easily operated stove with fold-out pot supports. The baffles on the burner reduces the effect of wind on the flame. It is great for use in the mountains.

- Power 3000W.
- Boils 1L of water in 4 minutes.
- Burner baffles.
- Supplied with storage box.
- Gas canisters - screw on butane propane mix.
- Approximate burn times: 110g - 30mins, 230g - 65mins, 450g - 125mins.

**SIZE**.... H8 x WØ12.3cm  
**CLOSED**.... H10.5 x WØ6.5cm  
**WEIGHT**.... 102g  
**CARTON QTY**.... 1



## ULTRALIGHT STOVE ACXSTOVEDALZ36

An ultralight stove with maximum power. The pot-support is simple to use and folds away to a compact, lightweight unit that can be stored and carried easily.

- Power 3000W.
- Boils 1L of water in 3 minutes
- Burner baffles.
- Supplied with storage box.
- Gas canisters - screw on butane propane mix.
- Approximate burn times: 110g - 35mins, 230g - 75mins, 450g - 145mins.

**SIZE**.... H8 x WØ12.3cm  
**CLOSED**.... H6.7 x WØ6.4cm  
**WEIGHT**.... 73g  
**CARTON QTY**.... 1



## FOLDING STOVE ACXSTOVE DAKZ36

The Folding Stove is great for larger pans or use on uneven surfaces with its ultra-wide flame spreader ensuring your food is cooked thoroughly even when it comes to larger loads.

- Ideal for large pots.
- Power 2600W.
- Boils 1L of water in 5 minutes.
- Ideal for large pots.
- Supplied with storage box.
- Gas canisters - Screw on butane propane mix
- Approximate burn times: 110g - 35mins, 230g - 75mins, 450g - 145mins.

**SIZE**.... H7 x WØ17cm  
**CLOSED**.... H6 x WØ10.5cm  
**WEIGHT**.... 220g  
**CARTON QTY**.... 1



## FOLDING STOVE ACXSTOVEDEWZ36 WITH WINDSHIELD & PIEZO

Made for the British weather, this high load bearing gas stove has an ultra-wide flame spreader so that even larger pans will be sure to cook thoroughly. Complete with Piezo ignitor whilst the windshield keeps the flame sheltered and steady.

- Ideal for large pots.
- Power 2500W.
- Boils 1L of water in 5 minutes.
- High quality Piezo ignitor.
- Built-in windshield.
- Supplied with storage box.
- Gas canisters - screw on butane propane mix.
- Approximate burn times: 110g - 35mins, 230g - 75mins, 450g - 145mins.

**SIZE**.... H7 x WØ17.4cm  
**CLOSED**.... H6 x WØ9cm  
**WEIGHT**.... 245g  
**CARTON QTY**.... 1



## ROAR STOVE ACXSTOVER28Z36

The Roar is the perfect stove for groups and adventurous families in the outdoors. Coming attached with a piezo igniter and pre heat tube, the Roar is suitable for use on the hill or in the campsite.

- Ideal for large pots.
- Power 3600W.
- Boils 1L of water in 3 minutes
- Supplied with storage box.
- Gas canisters - Screw on butane propane mix.
- Approximate burn times: 110g - 27mins, 230g - 57mins, 450g - 112mins.

**SIZE**.... H7 x WØ17cm  
**CLOSED**.... H9.5 x WØ6cm  
**WEIGHT**.... 585g  
**CARTON QTY**.... 1



## IGNITE ACXSTOVEDAMW37

Don't panic about forgetting to pack the matches simply keep this fire starter in your rucksack at all times.

- Suitable for all weathers.
- Magnesium alloy bar, with integrated steel striker.

**CARTON QTY**.... 1



## CAN STAND ACXSTOVEDAMW37

The Can Stand increases the stability of your stove on all terrain. Ideal for anyone using a canister top screw on stove.

**CARTON QTY**.... 1



## WINDSHIELD

The Windshield offers protection for your backpacking stove from the wind when out on the hills, campsite or on the beach. Suitable for all stoves in the Vango range.

- Lightweight Aluminium.
- Built-in pegs to aid stability.
- Supplied with storage bag.

**STANDARD** ACXSTOVE DEMW37

**OPEN**.... L60 x H14cm  
**FOLDED**.... L14 x W7 x H2cm  
**WEIGHT**.... 110g  
**CARTON QTY**.... 1

**XL** ACXSTOVE DEMW37

**OPEN**.... L68 x H24cm  
**FOLDED**.... L24 x W8 x H2cm  
**WEIGHT**.... 249g  
**CARTON QTY**.... 1



# COOKWARE

## HARD-ANODISED FRYING PAN

The Hard Anodised Frying Pan is strong and durable with folding handle for easy packing and storage.

- Folding heat resistant handle.

**SIZE**.....Ø19.5 X 4.5cm  
**WEIGHT** .....200g  
**CARTON QTY**....1



ACXCOOK HRAU10

## 1-PERSON HARD-ANODISED COOK KIT

2 pots with lid/mug combination, this Hard Anodised Cook Kit is great for solo travelers wanting to stop off for a quick meal.

- Shaped, heat resistant handles.
- Small pot/lid Ø12cm x 6cm.
- Large pot Ø12.5cm x 10.2cm.
- Storage bag.

**WEIGHT** .....225g  
**CARTON QTY**....1



ACXCOOKHRAU01

## 2-PERSON HARD-ANODISED COOK KIT

2 pots with lid/mug combination. This 2 person Hard Anodised Cook Kit is great for travellers wanting to stop off for a quick meal.

- Shaped, heat resistant handles.
- Small pot/lid Ø13 x 6.5cm.
- Large pot Ø14.5 x 11.2cm.
- Storage bag.

**WEIGHT** .....290g  
**CARTON QTY**....1



ACXCOOKHRAU02

## ADVENTURE HARD-ANODISED COOK KIT

Perfect for weekend campers with a full activity schedule wanting to stop off for a quick meal without worrying about having to scrape their pots and pans.

- Shaped, heat resistant handles.
- Frying pan Ø18 x 4.6cm.
- Small pan/lid Ø13.6 x 7.8cm.
- Large Pot Ø17 x 9.2cm.
- Storage bag.

**WEIGHT** .....560g  
**CARTON QTY**....1



ACXCOOKHRATAW

## ALUMINIUM KETTLE 1.3L

The Vango 1.3L Aluminium Kettle is lightweight, strong and durable with a folding heat-resistant handle which will last for many years.

- Lightweight aluminium.
- Folding heat resistant handle.
- Lid detaches completely.

**SIZE**.....Ø15.5 X 10.7cm  
**WEIGHT** .....210g  
**CARTON QTY**....1



ACXKETTLE232W18

## WAYFAYRER SPOON

Eat your Wayfayrer meal straight from the packet without getting your hands dirty or burnt and saving on the washing up!

- 22cm long handled design.
- High quality stainless steel construction.
- Lightweight and durable.

**WEIGHT** .....27g  
**CARTON QTY**....1

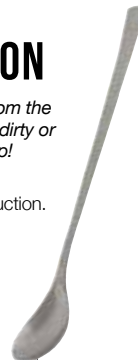

ACXCUTLER300W18

## KNIFE, FORK & SPOON SET

Compact cutlery set that clips together when not in use. Strong, durable and easy to clean.

- 1 x knife, 1 x fork, 1 x spoon.
- Clips together as one.

**SIZE**.....W17 x D2 x H1cm  
**WEIGHT** .....80g  
**CARTON QTY**....1



ACXCUTLER30GZ01

# VANGO FUEL

## SPIRIT FUEL



Made from renewable sources such as sugar beet, Vango Fuel's new Bio-Ethanol Spirit Fuel is designed and recommended for spirit burners by major manufacturers such as Trangia.

- Approved by The Scout Association for use on Scouting expeditions.
- Environmentally friendly.
- Made from a renewable source (sugar beet).
- Methanol free.
- Long burning and smokeless.
- Clean burning (50% reduction in CO2 emissions v fossil fuels).
- Spill-reducing insert and child safety cap.

**500ML**

**WEIGHT** 460g / **CARTON QTY** 12

**1L**

**WEIGHT** 880g / **CARTON QTY** 12



**The nozzle on the 200ml pouch fits snugly into the 1 litre refill nozzle.**

*This allows for safe and easy replenishment of the portable 200ml pouch, which is ideal for carrying in your rucksack.*



## GEL FUEL



Vango Fuel bio-ethanol gel is a smokeless, non-toxic and environmentally-friendly cooking fuel. The gel formulation doesn't spill, making it far safer than the alternative fuels on the market today. Developed specifically to address the problem of indoor air pollution in Africa, it's easy to ignite and allows for instant high heat cooking.

- Approved by The Duke of Edinburgh's Award and The Scout Association for use on expeditions.
- Environmentally friendly.
- Perfect for cooking, fire lighting and heating.
- Non-spill, non-toxic and smokeless.
- The 1 litre pack is built to refill the 200ml pouches. The nozzle on the pack connects together with an empty 200ml pouch, and allows for easy replenishing of the gel.
- 200ml pouch burns for approx. 60-90 mins.
- 1 litre pouch burns for approx. 7-9 hours.

**200ML**

**WEIGHT** 220g / **CARTON QTY** 20

**1L**

**WEIGHT** 860g / **CARTON QTY** 10



**Vango Gel Fuel is safe and easy to pour.**

*The viscous gel formulation has significantly less chance of spilling than liquid, making it far safer than alternative fuels on the market.*



**TRANGIA GEL BURNER C/O**

See Page 171





## **COOKING SYSTEM**

*Trangia stoves are available with pans and frypans made in four differing materials;*

**Ultralight Aluminium** is one of the lightest materials that conducts heat well. Trangia aluminium stoves systems spread the heat quickly and evenly. This reduces the likelihood of food burning and sticking to the pans. The hardened surface makes the system very scratch and wear resistant. Ultralight aluminium is 30% stronger than ordinary aluminium and as a result less material is needed making these lightweight stoves even lighter.

**Hard Anodised Aluminium** makes our pans and frypans even more resistant to scratching. Hard anodising is a surface treatment that also improves corrosion resistance and the treatment make the pans easier to clean than an untreated pan.

**Non-Stick pans and frypans** have a non-stick coating, which is an ideal surface for frying and can be used with little or no cooking fat. The coating also makes cleaning much easier, but it is slightly more susceptible to scratches and abrasion, hence plastic or wooden cooking utensils are suggested.

**Duossal** combines the benefits of cooking in an aluminium pan with the durability of a stainless steel cooking surface. The aluminium spreads the heat evenly over the surface of the pan or frypan, giving an even temperature and reducing the risk of burning the food. The inner surface of stainless steel is highly durable and scratch resistant.

# TRANGIA SERIES 25 3-4 PERSON

Series 25 offers a larger cook system suitable for groups of about 3-4 people.

These are excellent family cook systems with large pans, a wider frying pan and a larger kettle. The stove can be used with large billies from the rest of the Trangia range with the supports in the raised position. All the cook systems in the 25 Series have two pans (1.5L and 1.75L), a 22cm frying pan, windshields (upper and lower), a burner, a pan handle and a strap.

## 25-21

Stove with 1.75L and 1.5L saucepans, an 18cm frying pan, windshields, a burner, a pan grip and a strap



- Duossal • Duossal frying pan/lid 18cm
- 2 alloy pans 1L • Pan grip & strip • Gas burner

**WEIGHT** 1190g

**PACKED** 220 x 110 x 220cm

**CARTON QTY** 1

**STD ORDER QTY** 1

TRXCOOKER05BT90

## 25-6 UL

Alloy stove with non-stick pans, alloy kettle and spirit burner



- Ultralite alloy stove • Non-stick frying pan/lid 22cm
- 2 alloy pans 1.5L & 1.75L • Alloy kettle 0.9L • Spirit burner

**WEIGHT** 1085g

**PACKED** Ø22 x 10cm

**CARTON QTY** 1

**STD ORDER QTY** 1

TRXCOOKER01DT90

## 25-2 UL

Alloy stove with alloy pans, alloy kettle and gas burner.



- Ultralite alloy stove • Alloy frying pan/lid 22cm
- 2 alloy pans 1.5L & 1.75L • Alloy kettle 0.9L • Gas burner

**WEIGHT** 1025g

**PACKED** Ø22 x 10cm

**CARTON QTY** 1

**STD ORDER QTY** 1

TRXCOOKER01BT90

## 25-7 UL/HA

Alloy stove with hard-anodised pans and spirit burner



- Ultralite alloy stove • Hard-anodised frying pan/lid 22cm
- 2 hard-anodised 1.5L & 1.75L • Spirit burner

**WEIGHT** 690g

**PACKED** Ø18.5 x 9.5cm

**CARTON QTY** 1

**STD ORDER QTY** 1

TRXCOOKER02ST90

## 25-1 UL

Alloy stove with alloy pans and spirit burner



- Ultralite alloy stove • Alloy frying pan/lid 22cm
- 2 alloy pans 1.5L & 1.75L • Spirit burner

**WEIGHT** 845g

**PACKED** Ø22 x 10cm

**CARTON QTY** 1

**STD ORDER QTY** 1

TRXCOOKER01AT90

## 25-2 GB/UL

Alloy stove with alloy pans, alloy kettle and spirit burner.



- Ultralite alloy stove • Alloy frying pan/lid 22cm
- 2 alloy pans 1.5L & 1.75L • Alloy kettle 0.9L • Spirit burner

**WEIGHT** 1110g

**PACKED** Ø22 x 10cm

**CARTON QTY** 1

**STD ORDER QTY** 1

TRXCOOKER01BT88

## 25-8 UL/HA

Alloy stove with hard-anodised pans, alloy kettle and spirit burner



- Ultralite alloy stove • Alloy frying pan/lid 22cm
- 2 alloy pans 1.5L & 1.75L • Alloy kettle 0.9L • Gas burner

**WEIGHT** 825g

**PACKED** Ø18.5 x 9.5cm

**CARTON QTY** 1

**STD ORDER QTY** 1

TRXCOOKER02TT90

## 25-1 GB/UL

Alloy stove with alloy pans, alloy kettle and gas burner.



- Ultralite alloy stove • Alloy frying pan/lid 22cm
- 2 alloy pans 1.5L & 1.75L • Gas burner

**WEIGHT** 930g

**PACKED** Ø22 x 10cm

**CARTON QTY** 1

**STD ORDER QTY** 1

TRXCOOKER01AT88

## 25-5 GB/UL

Alloy stove with non-stick pans and gas burner



- Ultralite alloy stove • Non-stick frying pan/lid 22cm
- 2 non-stick pans 1.5L & 1.75L • Gas burner

**WEIGHT** 990g

**PACKED** Ø22 x 10cm

**CARTON QTY** 1

**STD ORDER QTY** 1

TRXCOOKER01CT88

# TRANGIA SERIES 27 1-2 PERSON

Series 27 offers a cook system for the solo walker or two people. The pans are smaller and the kettle is sized accordingly.

A small, compact cook system that takes up minimal room in your pack. Large billies can be accommodated on the raised supports in the upper windshield. All the cook systems in the 27 Series have two 1L pans, (1 graded, 1 ungraded) an 18cm frying pan, windshields (upper and lower), a burner, a pan handle and a strap.

## 27-23

Stove with two 1L saucepans (1 graded, 1 ungraded), an 18cm frying pan, windshields, a burner, a pan grip and a strap



- Duossal • Duossal frying pan/lid 18cm
- 2 alloy pans 1L • Pan grip & strap • Gas burner

**WEIGHT** 855g  
**PACKED** 185 x 105 x 185cm  
**CARTON QTY** 1  
**STD ORDER QTY** 1  
 TRXCOOKER05CT91

## 27-6 HA

Hard-anodised stove with non-stick pans, alloy kettle and spirit burner



- Hard-anodised stove • Non-stick frying pan/lid 18cm
- 2 non-stick pans 1L • Alloy kettle 0.6L • Spirit burner

**WEIGHT** 880g  
**PACKED** Ø18.5 x 9.5cm  
**CARTON QTY** 1  
**STD ORDER QTY** 1  
 TRXCOOKER019T91

## 27-2 UL

Alloy stove with alloy pans, alloy kettle and spirit burner



- Ultralite alloy stove • Alloy frying pan/lid 18cm
- 2 alloy pans 1L • Alloy kettle 0.9L • Gas burner

**WEIGHT** 825g  
**PACKED** Ø18.5 x 9.52cm  
**CARTON QTY** 1  
**STD ORDER QTY** 1  
 TRXCOOKER01BT91

## 27-7 UL/HA

Alloy stove with hard-anodised pans and spirit burner



- Ultralite alloy stove • Hard-anodised frying pan/lid 18cm
- 2 alloy pans 1L • Spirit burner

**WEIGHT** 690g  
**PACKED** Ø18.5 x 9.5cm  
**CARTON QTY** 1  
**STD ORDER QTY** 1  
 TRXCOOKER02ST91

## 27-1 UL

Alloy stove with alloy pans and spirit burner



- Ultralite alloy stove • Alloy frying pan/lid 18cm
- 2 alloy pans 1L • Spirit burner

**WEIGHT** 690g  
**PACKED** Ø18.52 x 9.5cm  
**CARTON QTY** 1  
**STD ORDER QTY** 1  
 TRXCOOKER01AT91

## 27-5 GB/UL

Alloy stove with non-stick pan and gas burner



- Ultralite alloy stove • Non-stick frying pan/lid 18cm
- 2 non-stick pans 1L • Gas burner

**WEIGHT** 830g  
**PACKED** Ø18.5 x 9.5cm  
**CARTON QTY** 1  
**STD ORDER QTY** 1  
 TRXCOOKER01CT89

## 27-8 UL/HA

Alloy stove with hard-anodised pans, alloy kettle and spirit burner.



- Ultralite alloy stove • Hard-anodised frying pan/lid 18cm
- 2 alloy pans 1L • Alloy kettle 0.6L • Spirit burner

**WEIGHT** 825g  
**PACKED** Ø18.5 x 9.5cm  
**CARTON QTY** 1  
**STD ORDER QTY** 1  
 TRXCOOKER02TT91

## 27-1 GB/UL

Alloy stove with alloy pans and gas burner



- Ultralite alloy stove • Alloy frying pan/lid 18cm
- 2 alloy pans 1L • Gas burner

**WEIGHT** 775g  
**PACKED** Ø18.5 x 9.5cm  
**CARTON QTY** 1  
**STD ORDER QTY** 1  
 TRXCOOKER01AT89

## 27-6 UL

Alloy stove with non-stick pans, alloy kettle and spirit burner



- Ultralite alloy stove • Non-stick frying pan/lid 18cm
- 2 non-stick pans 1L • Alloy kettle 0.6L • Spirit burner

**WEIGHT** 880g  
**PACKED** Ø18.5 x 9.5cm  
**CARTON QTY** 1  
**STD ORDER QTY** 1  
 TRXCOOKER01DT91

# ACCESSORIES **SERIES 25**

You can add to and personalise your equipment with Original Trangia Accessories. Start from your particular needs and choose from the many specially designed products, for the best quality and ideal performance.

Stoves and accessories are designed to take up minimal space, so you can pack your rucksack neatly and efficiently. We offer everything from ultra-light pans to bigger pans for larger groups - the choice is yours!

## ALUMINIUM SAUCEPAN 1.5L

A 1.5 litre capacity aluminium pan, perfect for cooking outdoors



**WEIGHT** 110g  
**PACKED** Ø17 x 7.5cm  
**CARTON QTY** 1  
**STD ORDER QTY** 1  
TRXCOOKAC01MT90

## NON-STICK SAUCEPAN 1.5L

A 1.5 litre capacity non-stick pan, perfect for cooking outdoors



**WEIGHT** 115g  
**PACKED** Ø17 x 7.8cm  
**CARTON QTY** 1  
**STD ORDER QTY** 1  
TRXCOOKAC010T90

## HARD-ANODISED SAUCEPAN 1.5L

A 1.5 litre capacity hard-anodised pan, perfect for cooking outdoors



**WEIGHT** 110g  
**PACKED** Ø17 x 7.5cm  
**CARTON QTY** 1  
**STD ORDER QTY** 1  
TRXCOOKAC02WT90

## DUOSSAL SAUCEPAN 1.5L

A 1.5 litre capacity duossal pan, perfect for cooking outdoors



**WEIGHT** 220g  
**PACKED** 230 x 130 x 240cm  
**CARTON QTY** 1  
**STD ORDER QTY** 1  
TRXCOOKAC01QT90

## ALUMINIUM SAUCEPAN 1.75L

A 1.75 litre capacity aluminium pan, graduated for easy measuring



**WEIGHT** 115g  
**PACKED** Ø18 x 7.7cm  
**CARTON QTY** 1  
**STD ORDER QTY** 1  
TRXCOOKAC01NT90

## NON-STICK SAUCEPAN 1.75L

A 1.75 litre capacity non-stick pan, graduated for easy measuring



**WEIGHT** 120g  
**PACKED** Ø18 x 7.9cm  
**CARTON QTY** 1  
**STD ORDER QTY** 1  
TRXCOOKAC01PT90

## HARD-ANODISED SAUCEPAN 1.75L

A 1.75 litre capacity hard-anodised pan, graduated for easy measuring



**WEIGHT** 115g  
**PACKED** Ø18 x 7.7cm  
**CARTON QTY** 1  
**STD ORDER QTY** 1  
TRXCOOKAC02XT90

## DUOSSAL SAUCEPAN 1.75L

A 1.75 litre capacity duossal pan, graduated for easy measuring



**WEIGHT** 220g  
**PACKED** 500 x 180 x 180cm  
**CARTON QTY** 1  
**STD ORDER QTY** 1  
TRXCOOKAC01RT90

## ALUMINIUM FRYING PAN 22cm

22cm diameter aluminium frying pan that doubles as a pot lid



**WEIGHT** 115g  
**PACKED** Ø22 x 3.3cm  
**CARTON QTY** 1  
**STD ORDER QTY** 1  
TRXCOOKAC01ST90

## NON-STICK FRYING PAN 22cm

22cm diameter non-stick frying pan that doubles as a pot lid



**WEIGHT** 165g  
**PACKED** Ø22 x 3.3cm  
**CARTON QTY** 1  
**STD ORDER QTY** 1  
TRXCOOKAC01TT90

## HARD-ANODISED FRYING PAN 1.5L

22cm diameter hard-anodised frying pan that doubles as a pot lid



**WEIGHT** 115g  
**PACKED** Ø22 x 3.3cm  
**CARTON QTY** 1  
**STD ORDER QTY** 1  
TRXCOOKAC01YT90

## DUOSSAL SAUCEPAN 1.5L

22cm diameter duossal frying pan that doubles as a pot lid



**WEIGHT** 205g  
**PACKED** 500 x 180 x 180cm  
**CARTON QTY** 1  
**STD ORDER QTY** 1  
TRXCOOKAC01UT90

## MULTIDISC 21cm

21cm multi-purpose plastic disc, can be used for food preparation, as a colander, lid or other utensil



## ALUMINIUM KETTLE 0.9L

Ultralight aluminium kettle with folding easy-grip handle



**WEIGHT** 86g  
**PACKED** Ø21 x 0.5cm  
**CARTON QTY** 1  
**STD ORDER QTY** 1  
TRXCOOKAC01ZT90

**WEIGHT** 190g  
**PACKED** Ø15 x 8.4cm  
**CARTON QTY** 1  
**STD ORDER QTY** 1  
TRXCOOKAC006T90

## STRAP 68cm

68cm strap to hold your Trangia pots and cooker securely in place, for easier transport and storage



## CARRY BAG

A brightly coloured protective bag for your Trangia 25 Cook Set



**WEIGHT** 20g  
**PACKED** 68 x 2cm  
**CARTON QTY** 1  
**STD ORDER QTY** 1  
TRXCOOKAC01YT90

**WEIGHT** 26g  
**PACKED** Ø34 x 5cm  
**CARTON QTY** 1  
**STD ORDER QTY** 1  
TRXCOOKAC01XT90

## LOWER WINDSHIELD

A 1.5 litre capacity non-stick pan, perfect for cooking outdoors



**WEIGHT** 120g  
**PACKED** Ø20 x 7.4cm  
**CARTON QTY** 1  
**STD ORDER QTY** 1  
TRXCOOKAC01WT90

## UPPER WINDSHIELD

Ultralight aluminium upper windshield, helps protect the cooking flame from the elements



**WEIGHT** 200g  
**PACKED** Ø20 x 9.5cm  
**CARTON QTY** 1  
**STD ORDER QTY** 1  
TRXCOOKAC01VT90

# ACCESSORIES **SERIES 27**

Replacement pans and frying pans made from lightweight aluminium, non-stick aluminium, hard-anodised aluminium or duossal. As well as a full range of products such as kettles and windshields to fully complement your Series 27 Cook System or to replace any damaged or lost items.

## ALUMINIUM SAUCEPAN 1L

A 1 litre capacity aluminium pan, perfect for cooking outdoors



**WEIGHT** 80g  
**PACKED** Ø15 x 6.8cm  
**CARTON QTY** 1  
**STD ORDER QTY** 1  
TRXCOOKAC01MT91

## NON-STICK SAUCEPAN 1L

A 1 litre capacity non-stick pan, perfect for cooking outdoors



**WEIGHT** 90g  
**PACKED** Ø15 x 6.7cm  
**CARTON QTY** 1  
**STD ORDER QTY** 1  
TRXCOOKAC010T91

## HARD-ANODISED SAUCEPAN 1L

A 1 litre capacity hard-anodised pan, perfect for cooking outdoors



**WEIGHT** 80g  
**PACKED** Ø15 x 6.8cm  
**CARTON QTY** 1  
**STD ORDER QTY** 1  
TRXCOOKAC02WT91

## DUOSSAL SAUCEPAN 1L

22cm diameter duossal frying pan that doubles as a pot lid



**WEIGHT** 145g  
**PACKED** 230 x 130 x 240cm  
**CARTON QTY** 1  
**STD ORDER QTY** 1  
TRXCOOKAC01KT91

## ALUMINIUM SAUCEPAN 1L

A 1 litre capacity aluminium pan, graduated for easy measuring



**WEIGHT** 80g  
**PACKED** Ø14.6 x 6.9cm  
**CARTON QTY** 1  
**STD ORDER QTY** 1  
TRXCOOKAC01NT91

## NON-STICK SAUCEPAN 1L

A 1 litre capacity non-stick pan, graduated for easy measuring



**WEIGHT** 90g  
**PACKED** Ø14.6 x 6.9cm  
**CARTON QTY** 1  
**STD ORDER QTY** 1  
TRXCOOKAC01PT91

## HARD-ANODISED SAUCEPAN 1L

A 1 litre capacity hard-anodised pan, graduated for easy measuring



**WEIGHT** 80g  
**PACKED** Ø14.6 x 6.9cm  
**CARTON QTY** 1  
**STD ORDER QTY** 1  
TRXCOOKAC02XT91

## DUOSSAL SAUCEPAN 1L (GRADUATED)

22cm diameter duossal frying pan that doubles as a pot lid



**WEIGHT** 145g  
**PACKED** 230 x 130 x 240cm  
**CARTON QTY** 1  
**STD ORDER QTY** 1  
TRXCOOKAC01LT92

## ALUMINIUM FRYING PAN 18cm

18cm diameter aluminium frying pan that doubles as a pot lid



**WEIGHT** 85g  
**PACKED** Ø18.8 x 3cm  
**CARTON QTY** 1  
**STD ORDER QTY** 1  
TRXCOOKAC01ST91

## NON-STICK FRYING PAN 18cm

18cm diameter non-stick frying pan that doubles as a pot lid



**WEIGHT** 120g  
**PACKED** Ø18.8 x 3cm  
**CARTON QTY** 1  
**STD ORDER QTY** 1  
TRXCOOKAC01TT91

## HARD-ANODISED FRYING PAN 18cm

18cm diameter hard-anodised frying pan that doubles as a pot lid



**WEIGHT** 85g  
**PACKED** Ø18.8 x 3cm  
**CARTON QTY** 1  
**STD ORDER QTY** 1  
TRXCOOKAC01YT91

## DUOSSAL FRYING PAN 1.5L

22cm diameter duossal frying pan that doubles as a pot lid



**WEIGHT** 150g  
**PACKED** 440 x 165 x 165cm  
**CARTON QTY** 1  
**STD ORDER QTY** 1  
TRXCOOKAC01UT91

## MULTIDISC 18cm

21cm multi-purpose plastic disc, can be used for food preparation, as a colander, lid or other utensil



**WEIGHT** 74g  
**PACKED** Ø18 x 0.5cm  
**CARTON QTY** 1  
**STD ORDER QTY** 1  
TRXCOOKAC01ZT91

## ALUMINIUM KETTLE 0.6L

Ultralight aluminium kettle with folding easy-grip handle



**WEIGHT** 140g  
**PACKED** Ø13.4 x 6.4cm  
**CARTON QTY** 1  
**STD ORDER QTY** 1  
TRXCOOKAC006T91

## STRAP 61cm

61cm strap to hold your Trangia pots and cooker securely in place, for easier transport and storage



**WEIGHT** 20g  
**PACKED** 61 x 2cm  
**CARTON QTY** 1  
**STD ORDER QTY** 1  
TRXCOOKAC01YT91

## CARRY BAG

A brightly coloured protective bag for your Trangia 25 Cook Set



**WEIGHT** 24g  
**PACKED** Ø20 x 5cm  
**CARTON QTY** 1  
**STD ORDER QTY** 1  
TRXCOOKAC01XT91

## LOWER WINDSHIELD

Ultralight aluminium lower windshield, helps protect the cooking flame from the elements



**WEIGHT** 90g  
**PACKED** Ø20.7 x 7.4cm  
**CARTON QTY** 1  
**STD ORDER QTY** 1  
TRXCOOKAC01WT91

## UPPER WINDSHIELD

Ultralight aluminium upper windshield, helps protect the cooking flame from the elements



**WEIGHT** 170g  
**PACKED** Ø20 x 9.5cm  
**CARTON QTY** 1  
**STD ORDER QTY** 1  
TRXCOOKAC01VT91

# COOK KITS

The Cook Kits in Trangia's Outdoor Plus range consist of various combinations of frypans and saucepans with different dimensions and design. This allows you to choose the combination that suits you best, whether cooking whilst at a campsite, boating, hiking, or away lightweight camping, find your own favourites!

## TRIANGLE

Perfect for ultra light outdoor cooking. Fits either the gas, gel or spirit burner, it forms a safe, stable base which can support pans or kettles over 10cm in diameter



**WEIGHT** 115g  
**PACKED** 12.3 x 8.5 x 0.5cm  
**CARTON QTY** 1  
**STD ORDER QTY** 1  
TRXCOOKKIT03DZ01

## MINI TRANGIA

This storm-proof, aluminium stove is lightweight, sturdy and practical. Perfect for one person or a couple of outdoor enthusiasts



**WEIGHT** 330g  
**PACKED** Ø15 x 6.7cm  
**CARTON QTY** 1  
**STD ORDER QTY** 1  
TRXCOOKKIT02QZ01

## ALUMINIUM KETTLE 1.4L

Oversized aluminium kettle that can be used on a Trangia 25, 27 or any other stove or wood fire



**WEIGHT** 225g  
**PACKED** Ø15 x 10.5cm  
**CARTON QTY** 1  
**STD ORDER QTY** 1  
TRXCOOKKIT02LZ01

## NON-STICK FRYING PAN 22cm

22cm non-stick frying pan with a folding handle. The non-stick coating gives the ideal surface for frying and requires little or no oil



**WEIGHT** 270g  
**PACKED** Ø22 x 3cm  
**CARTON QTY** 1  
**STD ORDER QTY** 1  
TRXCOOKKIT02MZ01

## BILLY CAN 2.5L

Aluminium billy with lid and handle that can be used with the Trangia 27 stove. To aid packing, the 27 stoves fit neatly inside the billy



**WEIGHT** 395g  
**PACKED** Ø20 x 13cm  
**CARTON QTY** 1  
**STD ORDER QTY** 1  
TRXCOOKKIT02NZ01

## BILLY CAN 4.5L

Aluminium billy with lid and handle that can be used with the Trangia 25 stove. To aid packing, the 27 stoves fit neatly inside the billy



**WEIGHT** 530g  
**PACKED** Ø24 x 13cm  
**CARTON QTY** 1  
**STD ORDER QTY** 1  
TRXCOOKKIT02OZ01

## ALUMINIUM PLATE 20cm

Can be stored neatly under the lower windshield when packed. Additionally the plate can be used as a cutting board or as a cover for pans to keep food warm whilst another pan is being heated



**WEIGHT** 180g  
**PACKED** Ø20 x 2cm  
**CARTON QTY** 1  
**STD ORDER QTY** 1  
TRXCOOKKIT02PZ01

## CAMP SET

Camping set in aluminium with 1.5L saucepan, 18cm frying pan and detachable handle



**WEIGHT** 350+g  
**PACKED** Ø18.5 x 8cm  
**CARTON QTY** 1  
**STD ORDER QTY** 1  
TRXCOOKKIT016Z01

## MESS TIN

Aluminium mess tin with lid and handle



**WEIGHT** 160g  
**PACKED** 16.5 x 6.5 x 9cm  
**CARTON QTY** 1  
**STD ORDER QTY** 1  
TRXCOOKKIT007Z01

## TUNDRA COOK KITS

A set without a burner, designed to suit gas stoves. The 1.5 & 1.75L non-stick pans and the 20cm frying pan/lid have milled bases so they do not slip on the gas stove. This set is ideal for boats, caravans or holiday cabins. Supplied with a Trangia pan handle and storage bag for easy storage or transportation

## TUNDRA 1

2 non-stick pans (1.5L & 1.75L) 20cm non-stick frying pan, pan handle and storage bag



**WEIGHT** 540g  
**PACKED** Ø29 x 9.5cm  
**CARTON QTY** 1  
**STD ORDER QTY** 1  
TRXCOOKKIT013Z01

## TUNDRA 2

2 non-stick pans (1.5L & 1.75L) lid with handle that fits both pans, pan handle and storage bag



**WEIGHT** 440g  
**PACKED** Ø20 x 9.5cm  
**CARTON QTY** 1  
**STD ORDER QTY** 1  
TRXCOOKKIT014Z01

## TUNDRA 3

2 non-stick pans (1.5L & 1.75L) 20cm non-stick frying pan, lid with handle that fits both pans, pan handle and storage bag



**WEIGHT** 620g  
**PACKED** Ø20 x 9.5cm  
**CARTON QTY** 1  
**STD ORDER QTY** 1  
TRXCOOKKIT015Z01

# GENERAL ACCESSORIES

Choose from a variety of specially designed products to compliment your Tranga Stove to ensure you have the best possible experience whilst on your travels and adventures.

## SPIRIT BURNER

Trangia Spirit Burner with screwcap, washer and simmer ring. Simple to light, no matter what the conditions. Lightweight and easy to store while on the road



**WEIGHT** 110g  
**CARTON QTY** 1  
**STD ORDER QTY** 1  
 TRXACCESS02EZ01

## RUBBER WASHERS (2)

A pack of 2 spare washers to fit the Trangia burner screwcap. These prevent spirit fuel leaking from the burner when it is being transported



**WEIGHT** 6g  
**CARTON QTY** 1  
**STD ORDER QTY** 1  
 TRXACCESS02HZ01

## SCREWCAP & WASHER

Spare screw cap for Trangia spirit stoves, with rubber washer



**WEIGHT** 220g  
**CARTON QTY** 1  
**STD ORDER QTY** 1  
 TRXACCESS02FZ01

## SIMMER RING

Spare simmering ring for use with the Trangia Spirit Burner, to create a simmering flame and extinguish the burner



**WEIGHT** 24g  
**CARTON QTY** 1  
**STD ORDER QTY** 1  
 TRXACCESS02GZ01

## GEL BURNER

Alternative burner for use with fuels such as gels (Vango Fuel), solid fuel blocks or nightlight candles



**WEIGHT** 23g  
**CARTON QTY** 1  
**STD ORDER QTY** 1  
 TRXACCESS00OZ01

## GEL BURNER

Primus system. Fits in lower windshield as an alternative to the spirit burner. High efficiency, easy control and fits the Trangia Triangle and all Trangia stoves except from the Mini Trangia



**WEIGHT** 180g  
**CARTON QTY** 1  
**STD ORDER QTY** 1  
 TRXACCESS02DZ01

## MULTI-FUEL BURNER

Easily regulated multi-fuel burner that can burn white gas, petrol, kerosene and diesel. Fits in lower windshield. Includes self-cleaning shaker jet and fuel bottle



**WEIGHT** 525g  
**CARTON QTY** 1  
**STD ORDER QTY** 1  
 TRXACCESS02IZ01

## FUEL BOTTLE 0.3L

In durable polyethylene with an easy por cap and safety valve, the Fuel Bottle is essential for storing and transporting flammable fuels



**WEIGHT** 95g  
**DIMENSIONS** Ø65 x 119mm  
**CARTON QTY** 1  
**STD ORDER QTY** 1  
 TRXACCESS03BZ01

## FUEL BOTTLE 0.5L

In durable polyethylene with an easy por cap and safety valve, the Fuel Bottle is essential for storing and transporting flammable fuels



**WEIGHT** 115g  
**DIMENSIONS** Ø65 x 119mm  
**CARTON QTY** 1  
**STD ORDER QTY** 1  
 TRXACCESS02AZ01

## FUEL BOTTLE 1L

In durable polyethylene with an easy por cap and safety valve, the Fuel Bottle is essential for storing and transporting flammable fuels



**WEIGHT** 115g  
**DIMENSIONS** Ø65 x 119mm  
**CARTON QTY** 1  
**STD ORDER QTY** 1  
 TRXACCESS02BZ01

## SAFETY VALVE

Safety valve for use with all sizes of Trangia Fuel Bottle



**WEIGHT** 26g  
**CARTON QTY** 1  
**STD ORDER QTY** 1  
 TRXACCESS02CZ01

## PAN HANDLE

One size fits all replacement/spare Trangia aluminium pan handle



**WEIGHT** 48g  
**CARTON QTY** 1  
**STD ORDER QTY** 1  
 TRXACCESS01OZ01



## WAYFAYRER MEALS

*Real food, ready to eat. High quality Wayfayrer meals will give you all the energy you need for a big day out. Wayfayrer meals provide a substantial meal and satisfy the heartiest of appetites whilst camping, walking climbing, sailing and all other outdoor activities. Sealed in an individual, robust pouch, the tasty, pre-cooked meals are easy to carry, simple to prepare and can served hot, after immersing the pouch in boiling water for seven to eight minutes, or eaten cold. Equally at home in the countryside or in the Himalayas, Wayfayrer meals have been tried and tested at the ends of the earth and are the first choice of food for adventures and expedition teams.*

*With a 3 year shelf life, Wayfayrer meals are protected in a durable 4 layer laminate, flat pouch which is designed to allow easy and compact storage in your rucksack. Each pouch is burst resistant and has a foil barrier to protect the meal inside from harmful UV light, which can taint the colour, reduce the shelf life and quality of the meal.*

### PACK CONSTRUCTION

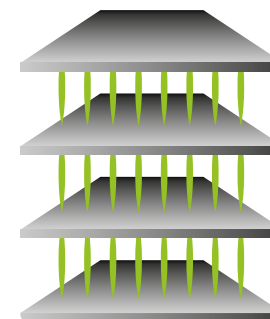

#### POLYESTER

Protective outer layer

#### NYLON

Puncture resistant layer

#### ALUMINIUM

Barrier to light, moisture & oxygen

#### POLYPROPYLENE

Food grade contact material



# WAYFAYRER MAIN MEALS



\*Nutritional values per 100g



## PASTA & BOLOGNESE



Conchiglie pasta and minced beef in a rich tomato bolognese sauce infused with garlic, basil & oregano

<b>ENERGY</b>	464kj/110kcal
<b>PROTEIN</b>	6.9g
<b>CARBS</b>	13.2g
<b>FAT</b>	3.5g
<b>ALLERGENS</b>	Gluten, Egg
<b>WEIGHT</b>	300g
<b>CARTON QTY</b>	6
<b>STD ORDER QTY</b>	6

## PASTA & MEATBALLS



Beef meatballs in an Italian style tomato sauce with conchiglie pasta

<b>ENERGY</b>	501kj/119kcal
<b>PROTEIN</b>	8.0g
<b>CARBS</b>	11.7g
<b>FAT</b>	4.5g
<b>ALLERGENS</b>	Gluten from wheat, Egg & Soya
<b>WEIGHT</b>	300g
<b>CARTON QTY</b>	6
<b>STD ORDER QTY</b>	6

## CHILLI CON CARNE & RICE



Minced beef with tomatoes, red kidney beans, onion and peppers in a cayenne & cumin sauce with long grain rice

<b>ENERGY</b>	614kj/145kcal
<b>PROTEIN</b>	5.6g
<b>CARBS</b>	17.2g
<b>FAT</b>	6.0g
<b>ALLERGENS</b>	Gluten
<b>WEIGHT</b>	300g
<b>CARTON QTY</b>	6
<b>STD ORDER QTY</b>	6

## VEGETABLE CURRY & RICE



Mixed vegetables & pulses in a medium spiced curry sauce with long grain rice

<b>ENERGY</b>	464kj/110kcal
<b>PROTEIN</b>	6.9g
<b>CARBS</b>	13.2g
<b>FAT</b>	3.5g
<b>ALLERGENS</b>	Gluten, Egg
<b>WEIGHT</b>	300g
<b>CARTON QTY</b>	6
<b>STD ORDER QTY</b>	6

## VEGETABLE CHILLI



Mixed vegetables in a chilli sauce with wholegrain brown rice

<b>ENERGY</b>	510kj/122kcal
<b>PROTEIN</b>	9.0g
<b>CARBS</b>	9.9g
<b>FAT</b>	3.9g
<b>ALLERGENS</b>	Celery, Soya & Barley
<b>WEIGHT</b>	300g
<b>CARTON QTY</b>	6
<b>STD ORDER QTY</b>	6

## SPICY SAUSAGE PASTA



Sliced pork sausage with pasta shells in a spicy tomato sauce

<b>ENERGY</b>	533kj/127kcal
<b>PROTEIN</b>	4.5g
<b>CARBS</b>	13.0g
<b>FAT</b>	5.8g
<b>ALLERGENS</b>	Gluten from wheat, Egg & Milk
<b>WEIGHT</b>	300g
<b>CARTON QTY</b>	6
<b>STD ORDER QTY</b>	6

## BEANS & BURGERS



Beans and burger bites with diced potatoes in tomato sauce

<b>ENERGY</b>	593kj/142kcal
<b>PROTEIN</b>	7.3g
<b>CARBS</b>	15.0g
<b>FAT</b>	4.9g
<b>ALLERGENS</b>	Gluten from wheat
<b>WEIGHT</b>	300g
<b>CARTON QTY</b>	6
<b>STD ORDER QTY</b>	6

## CHICKEN TIKKA & RICE



Chicken pieces in a rich tomato & coriander sauce with long grain rice

<b>ENERGY</b>	634kj/151kcal
<b>PROTEIN</b>	7.2g
<b>CARBS</b>	16.4g
<b>FAT</b>	6.3g
<b>ALLERGENS</b>	Gluten, milk, soya & mustard
<b>WEIGHT</b>	300g
<b>CARTON QTY</b>	6
<b>STD ORDER QTY</b>	6

## BREAKFAST \*Nutritional values per 100g

### ALL DAY BREAKFAST



*Beans in rich tomato sauce with succulent pork sausages, diced smoky bacon and ormelette*

<b>ENERGY</b>	504kj/120kcal
<b>PROTEIN</b>	6.8g
<b>CARBS</b>	13.9g
<b>FAT</b>	4.1g
<b>ALLERGENS</b>	Gluten from wheat, egg & dairy
<b>WEIGHT</b>	300g
<b>CARTON QTY</b>	6
<b>STD ORDER QTY</b>	6

### BEANS & SAUSAGE



*Beans in rich tomato sauce with succulent pork sausage*

<b>ENERGY</b>	603kj/144kcal
<b>PROTEIN</b>	5.0g
<b>CARBS</b>	16.1g
<b>FAT</b>	6.6g
<b>ALLERGENS</b>	Gluten from wheat
<b>WEIGHT</b>	300g
<b>CARTON QTY</b>	6
<b>STD ORDER QTY</b>	6



*The 22cm long handled Wayfayrer spoon is perfect for eating straight out of the packet!*

## BREAKFAST CHOCOLATE PUDDING



*A light, fluffy chocolate sponge covered in a rich chocolate sauce*

<b>ENERGY</b>	895kj/213kcal
<b>PROTEIN</b>	2.8g
<b>CARBS</b>	29.6g
<b>FAT</b>	9.3g
<b>ALLERGENS</b>	Gluten from wheat, soya & dairy
<b>WEIGHT</b>	300g
<b>CARTON QTY</b>	6
<b>STD ORDER QTY</b>	6

## STICKY TOFFEE PUDDING



*A delicious sticky toffee pudding in a rich, creamy toffee sauce*

<b>ENERGY</b>	1231kj/293kcal
<b>PROTEIN</b>	3.3g
<b>CARBS</b>	43.2g
<b>FAT</b>	11.9g
<b>ALLERGENS</b>	Soya, milk and gluten from wheat
<b>WEIGHT</b>	300g
<b>CARTON QTY</b>	6
<b>STD ORDER QTY</b>	6

## GINGER PUDDING & SAUCE



*Ginger sponge pudding with a sweet ginger sauce*

<b>ENERGY</b>	1226kj/292kcal
<b>PROTEIN</b>	3.3g
<b>CARBS</b>	40g
<b>FAT</b>	13g
<b>ALLERGENS</b>	Milk & gluten from wheat
<b>WEIGHT</b>	300g
<b>CARTON QTY</b>	6
<b>STD ORDER QTY</b>	6



## RUCKSACKS

*With our heritage in trekking packs, Vango have long been established as the leaders in the market place for long distance, high volume rucksacks. For 2018 we have elevated the range by welcoming two new F10 Series packs into the fold.*

*Our day and travel ranges have been completely updated with fantastic new and innovative fabrics in both along with new styles and designs.*

*Look out for our new Cationic Nylon fabric on our Day range, a 420D high strength nylon with nearly 4 times the rip strength of standard polyester and excellent abrasion resistance. The urban colours look just at home on the high street as they will on the hill and a host of technical features and branded components keep you fully prepared whatever the environment.*

*Our new travel range features our innovative PROTEX® 4:2 fabric developed by our product team as a light weight, abrasion resistant alternative to PVC. It is lighter, 2 times stronger with 1.6 times the tear strength of PVC and is significantly more environmentally friendly than it too. The range has been developed with feedback from our team who spend a significant amount of time travelling so whether it's a carry on rucksack, a full blown suitcase or a cargo bag that you can throw kit in and go the new range will meet all of your needs in a tough and light weight package.*

TRAVEL COLLECTION  
 DAY COLLECTION  
 HYDRATION COLLECTION  
 ACTIVE COLLECTION  
 TREKKING COLLECTION

# RANGE OVERVIEW

## TRAVEL COLLECTION



**PAC**  
15



**CARGO II**  
60 / 80 / 100 / 120



**NAVIGATOR**  
25



**NOMAD**  
45



**RUNWAY**  
40



**EXODUS**  
60+15



**FREEDOM II**  
60+20 / 80+20

## DAY COLLECTION



**LYT**  
15 / 20



**STRYD**  
22 / 26



**FLUX**  
22 / 28



**FYR**  
25 / 30



**DRYFT**  
28 / 34

## HYDRATION COLLECTION



**SPRINT**  
3



**SWIFT**  
10



**RAPIDE**  
20

## ACTIVE COLLECTION



**CALDERA**  
40 / 60 / 80 / 100



**V17**  
17



**ALPLITE**  
35 / 45



**GR**  
35:40 / 45:50



**HUT**  
35 / 45

## TREKKING COLLECTION



**PATHFINDER**  
55 / 65



**CONTOUR**  
50:60 / 60:70



**SHERPA**  
60:70S / 60:70  
65 / 70:80



**PINNACLE**  
60:70 / 70:80



**F10 TMB**  
60:70



**F10 PCT**  
50:60S / 60:70



High quality SBS® zips



Suspended laptop/tablet sleeve



Duraflex® buckles

**RUCKSACKS**

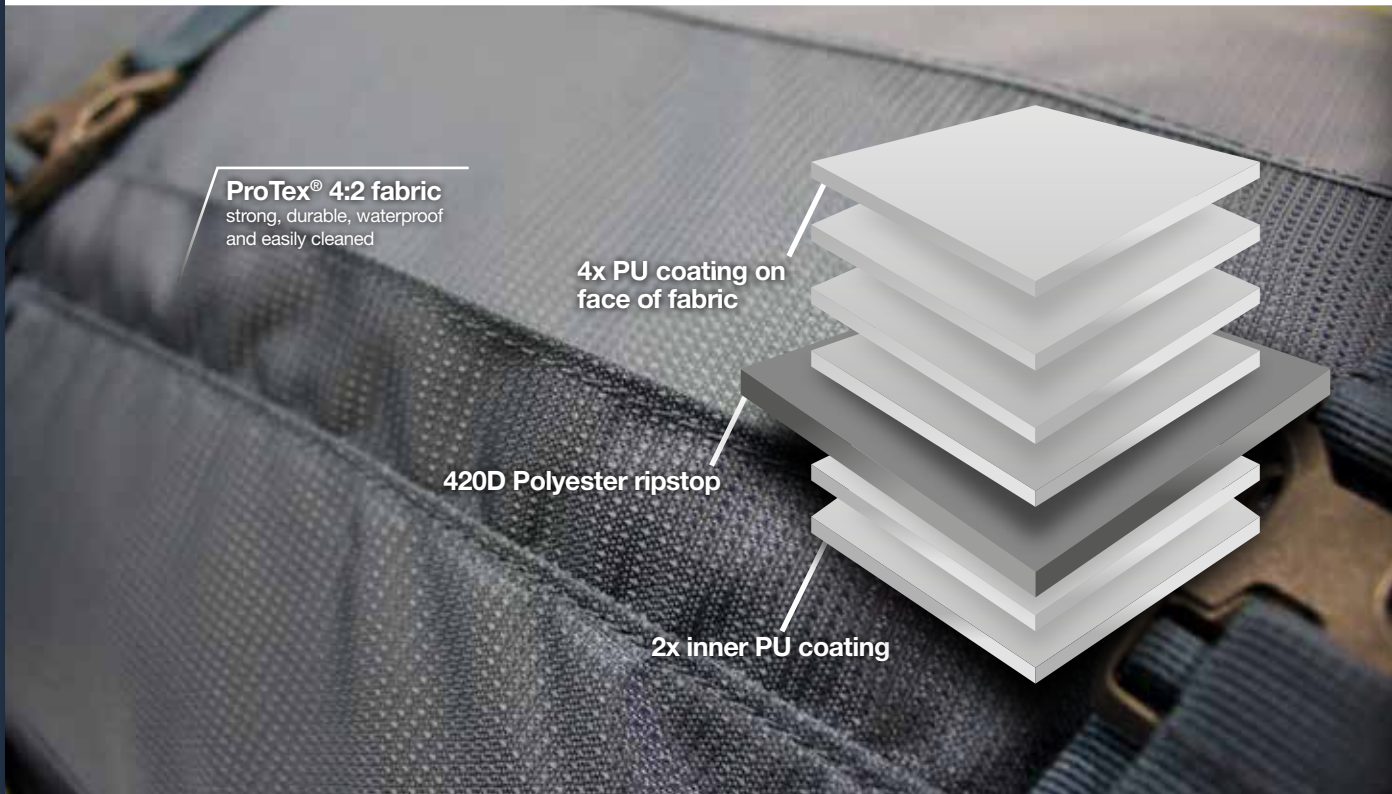

**ProTex® 4:2 fabric**  
strong, durable, waterproof and easily cleaned

4x PU coating on face of fabric

420D Polyester ripstop

2x inner PU coating

**TRAVEL COLLECTION**

Brand new for 2018, our travel collection features a brilliant new fabric developed to be low weight and extra durable. Designed from the ground up, and tested by our long distance travellers, the range covers all of your travel needs from carry on bags and robust cargo bags to roller cases and rucksacks to travel the globe.

Our innovative new PROTEX® 4:2 fabric is lighter and more environmentally friendly than traditional PVC with twice the rip strength and 1.6x the stitch retention while being just as abrasion resistant making the range a great light and durable addition to your journey.



# PAC

The Pac is a 15 litre rucksack which is perfect for those on the move and wanting to stay compact and light. Folding neatly into its own front pocket, this handy rucksack is ideal for popping into or clipping onto your main travel bag for use as a day bag.

- Excel® 200D nylon, lightweight yet highly durable.
- AirMesh on underside of shoulder straps.
- Pack stows away into its own pocket.
- Vango cord zip pull, easy to find and use.
- Duraflex buckles - strong and reliable.
- Zip access to main compartment.



**15**  
**CAPACITY** 15 litres  
**WEIGHT** 180g  
**DIMENSIONS**  
 L17 / W26 / H40cm  
**CARTON QTY** 30  
**STD ORDER QTY** 10

**BLACK**  
 RUMPACB05015



**PURPLE**  
 RUMPACP16015

# CARGO II NEW

The Cargo is the ideal kit bag for sports equipment and also great for overnight stays and weekend trips. This bag is extremely strong and robust, as well as highly flexible with its grab handles and stow away shoulder straps.

- Protex® 4:2 Fabric
- Zip access to main compartment.
- Stow-away shoulder straps.
- Zip mesh pocket inside the lid.
- Grab handles at centre and both ends.
- Lockable kissing zips, additional security for travel.
- ID sleeve.
- Duraflex buckles.

**60** RUNCARGO G38065  
**CAPACITY** 60 litres  
**WEIGHT** 880g  
**DIMENSIONS**  
 L34 / W50 / H34cm  
**CARTON QTY** 30  
**STD ORDER QTY** 5

**100** RUNCARGO G38077  
**CAPACITY** 100 litres  
**WEIGHT** 1.20kg  
**DIMENSIONS**  
 L40 / W70 / H40cm  
**CARTON QTY** 30  
**STD ORDER QTY** 5

**80** RUNCARGO G38070  
**CAPACITY** 80 litres  
**WEIGHT** 1.02kg  
**DIMENSIONS**  
 L35 / W60 / H35cm  
**CARTON QTY** 30  
**STD ORDER QTY** 5

**120** RUNCARGO G38086  
**CAPACITY** 120 litres  
**WEIGHT** 1.40kg  
**DIMENSIONS**  
 L44 / W75 / H44cm  
**CARTON QTY** 30  
**STD ORDER QTY** 5



**CARBIDE GREY**  
 80 shown



# NAVIGATOR NEW HERO

Sleek urban design meets robust outdoor rucksack construction to produce the ideal everyday commuter bag. The Navigator 25 uses ultra strong Protex 4:2 fabric. Designed to keep things organised and safe, this backpack includes a padded laptop & tablet sleeve, wide opening main compartment, a quick access front pocket and it is carry on compliant.

## 25

**CAPACITY** 25 litres  
**WEIGHT** 780g  
**DIMENSIONS** L20 / W32 / H50cm  
**CARTON QTY** 5  
**STD ORDER QTY** 5

- AirForce back system - Contoured air channels create a chimney effect that enhances ventilation while active. Channels are covered with highly breathable AirMesh offering a great back system for medium capacity packs
- Protex 4:2 Fabric - An innovative new fabric from Vango. Made with 420D Ripstop polyester with 2 coatings of PU on the inner face and 4 PU coatings on the outer face providing the perfect lightweight and durable combination.
- Keeps laptop safe and secure with retaining strap and internal padding. For laptops up to 16"
- Zip access to main compartment - Provides quick access to pack contents
- Organisation pocket - Keep essentials safe and easy to access
- Zip mesh pocket inside the lid - Allows easy storage and identification of contents
- AirMesh on rucksack straps - Allows air to flow, keeping the user cool
- Duraflex buckles - Strong and reliable
- Webbing handle on back of pack for fastening to trolley case handle



**CARBIDE GREY**  
 RUNNAVIGA G10036

# NOMAD NEW HERO

Sleek urban design meets robust outdoor rucksack construction to produce the ultimate weekend bag. The Protex 4:2 fabric used in this overnight bag is strong and durable thanks to its ripstop six coated construction. Designed to keep things organised and safe, this backpack includes a storable harness, padded laptop & tablet sleeve, wide opening main compartment, a quick access front pocket and it is carry on compliant.

Detachable  
 shoulder straps  
 & stowable harness

## 45

**CAPACITY** 45 litres  
**WEIGHT** 1.20kg  
**DIMENSIONS** L22 / W34 / H51cm  
**CARTON QTY** 10  
**STD ORDER QTY** 5

- AirForce back system - Contoured air channels create a chimney effect that enhances ventilation while active. Channels are covered with highly breathable AirMesh offering a great back system for medium capacity packs
- Protex 4:2 Fabric - An innovative new fabric from Vango. Made with 420D Ripstop polyester with 2 coatings of PU on the inner face and 4 PU coatings on the outer face providing the perfect lightweight and durable combination.
- Keeps laptop safe and secure with retaining strap and internal padding. For laptops up to 16"
- External access laptop sleeve - Provides rapid access to laptop. Fly through airport security, or grab a quick session on your laptop with ease
- Zip access to main compartment - Provides quick access to pack contents
- Organisation pocket - Keep essentials safe and easy to access
- Zip mesh pocket inside the lid - Allows easy storage and identification of contents
- Stow-away shoulder straps - Easy to store away and access when needed



**CARBIDE GREY**  
 RUNNOMAD G10060



# RUNWAY NEW

Part of the Planet Series, the Runway 40 combines sleek good looks with the robust outdoor construction expected from Vango. The Protex 4:2 fabric used in this overnight bag is strong and durable thanks to its ripstop six coated construction. Near silent running wheels have been incorporated at the base of this carry on bag to make traveling through the airport a slightly more tranquil experience. The Runway has a large main compartment with compression straps ideal for keeping clothes tidy. There is also a large front section which includes organiser pockets and padded tablet and laptop compartments. This well balanced overnight bag is a reliable companion for the frequent traveler

- Protex 4:2 Fabric - An innovative new fabric from Vango. Made with 420D Ripstop polyester with 2 coatings of PU on the inner face and 4 PU coatings on the outer face providing the perfect lightweight and durable combination.
- Keeps laptop safe and secure with retaining strap and internal padding. For laptops up to 16"
- Zip access to main compartment - Provides quick access to pack contents
- Organisation pocket - Keep essentials safe and easy to access
- Zip mesh pocket inside the lid - Allows easy storage and identification of contents
- Internal straps - Keeps contents tidy and secure

**40**  
**CAPACITY** 40 litres  
**WEIGHT** 2.74g  
**DIMENSIONS**  
 L22 / W34 / H53m  
**CARTON QTY** 2  
**STD ORDER QTY** 5



CARBIDE GREY  
 RUNRUNWAYG10055

# EXODUS NEW

For extended trips, the Exodus 60+20 is the ideal companion for multi-stop journeys. Featuring various carry options including near silent rubber wheels + tow handle, a zip-away rucksack harness, and multiple grab handles, you'll travel with ease whether you're strolling through the airport or train hopping through a city. This clever roller bag includes a huge 60L hold case and a detachable 20L, fully featured rucksack, including padded laptop sleeve, for when you reach your destination. The new Protex® 4:2 fabric keeps weight down without compromising on durability so it will be sure to last you trip after trip.

- Protex 4:2 Fabric - An innovative new fabric from Vango. Made with 420D Ripstop polyester with 2 coatings of PU on the inner face and 4 PU coatings on the outer face providing the perfect lightweight and durable combination.
- Keeps laptop safe and secure with retaining strap and internal padding. For laptops up to 16"
- Lockable kissing zips - Additional security for travel
- Zip access to main compartment - Provides quick access to pack contents
- Organisation pocket - Keep essentials safe and easy to access
- Zip mesh pocket inside the lid - Allows easy storage and identification of contents
- Internal straps - Keeps contents tidy and secure
- Side Compression Straps - to secure your load
- Central grab handle - For easy carrying and moving
- Two wheeled chassis - With extendable handle for easy travelling

**60+20**  
**CAPACITY** 60+20 litres  
**WEIGHT** 4.16kg  
**DIMENSIONS**  
 L26 / W40 / H67cm  
**STD ORDER QTY** 5



CARBIDE GREY  
 RUNEXODUSG38R01

## 20L FULLY FEATURED DAY PACK

- Laptop/tablet sleeve
- Side pockets
- Front pocket
- Organiser pocket
- AirForce back system

**CAPACITY** 20 litres  
**WEIGHT** 680g  
**DIMENSIONS**  
 L16 / W23 / H40cm





# FREEDOM II NEW

Part of the Planet Series, the Freedom 80 + 20 travel bag is the ultimate globetrotting companion. Designed to withstand the demands of long distance travel, this pack is extremely rugged due to its ground breaking Protex 4:2 fabric construction.

- Quick Adjust Back System (QA) - Coupling a contoured alloy frame for load distribution with a webbing ladder arrangement for back length adjustment. The Quick-Step system offers uncomplicated adjustment, comfort and durability
- Protex 4:2 Fabric - An innovative new fabric from Vango. Made with 420D Ripstop polyester with 2 coatings of PU on the inner face and 4 PU coatings on the outer face providing the perfect lightweight and durable combination.
- Removable daysack - Perfect for hand luggage, or day trips when you reach your destination
- Lockable kissing zips - Additional security for travel
- Daysack attaches to harness - for hands free carrying of both packs
- Sternum strap - Provides a secure fit
- AirMesh on rucksack straps - Allows air to flow, keeping the user cool
- Webbing grab handle between shoulder straps
- Duraflex buckles - Strong and reliable
- Ergonomic padded hip belt - Shaped for optimum load transfer and comfort

## 60+20

**CAPACITY** 60+20 litres

**WEIGHT** 2.92kg

**DIMENSIONS**

L28 / W38 / H63cm

**STD ORDER QTY** 5



**CARBIDE GREY/VOLT BLUE**  
RUNFREEDOG38R0N



**CARBIDE GREY/CARRIBEAN GREEN**  
RUNFREEDOG41R0N

**TURBULENT BLUE**  
RUNFREEDOB09R0N

## 20L FULLY FEATURED DAY PACK

- Hydration compatible
- Side pockets
- Front pocket
- Organiser pocket
- AirForce back system

**CAPACITY** 20 litres

**WEIGHT** 640g

**DIMENSIONS**

L16 / W23 / H40cm

## 80+20

**CAPACITY** 80+20 litres

**WEIGHT** 3.16kg

**DIMENSIONS**

L28 / W40 / H70cm

**STD ORDER QTY** 5



**TURBULENT BLUE**  
RUNFREEDOB09R0O

**CARBIDE GREY**  
RUNFREEDOG38R0O

**Flight cover**  
Stow away straps and hip belt





**Hydration compatible**

H<sub>2</sub>O



**420D Cationic Nylon**

Abrasion resistance: 30,000 cycles - no damage



**AirMesh**

Lightweight, breathable mesh, used on backsystem and harness



**Duraflex® buckles**

**RUCKSACKS**

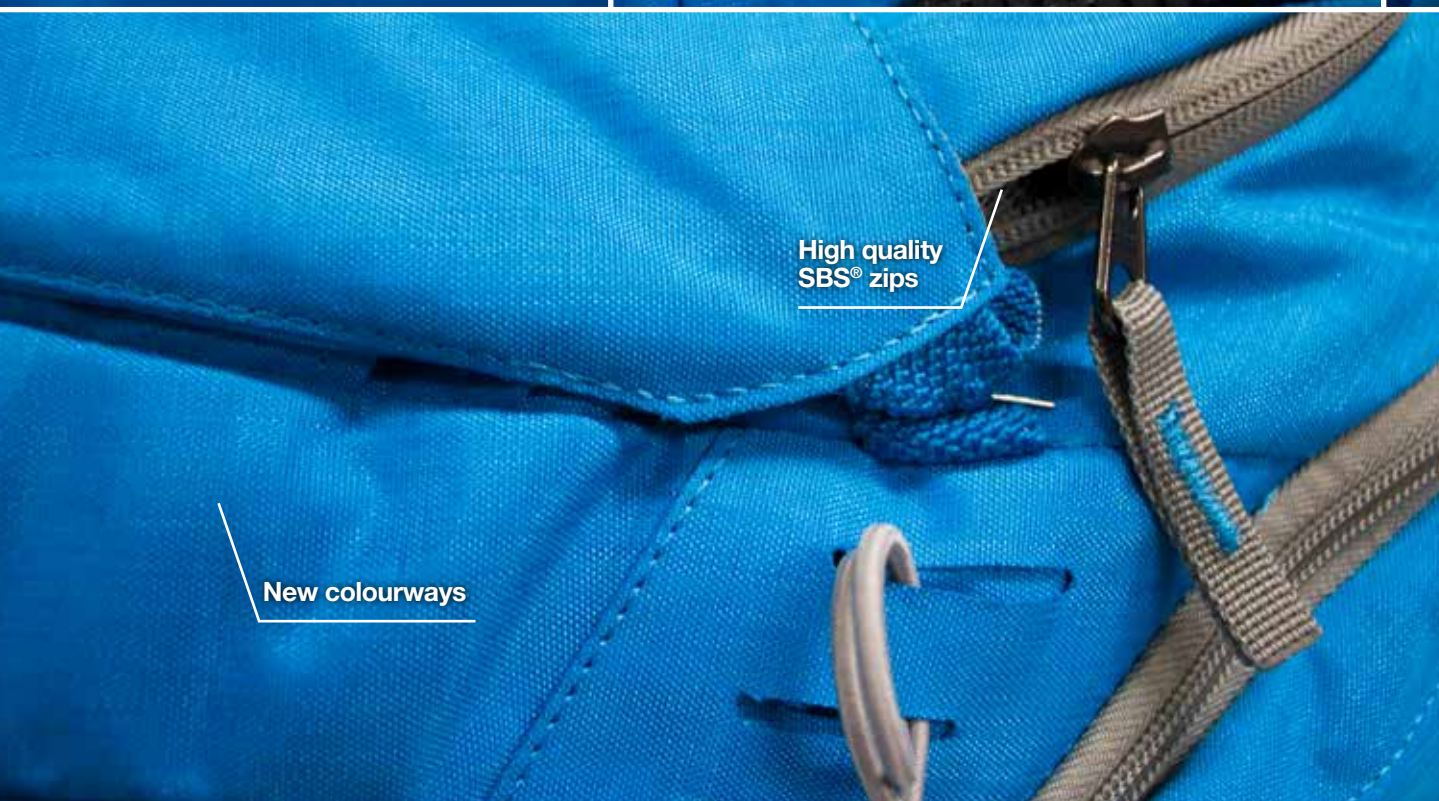

**High quality SBS® zips**

**New colourways**

## DAY & HYDRATION PACKS

Our day range has been replaced with a brand new collection of bright and functional packs to take you from light, urban usage to single day adventures out on the hill.

The range introduces a high quality 420D Cationic Nylon fabric which not only looks fantastic, it has 3.7x the rip strength and 1.6x stitch retention of polyester for exceptional durability and quality.

Of course, our rucksacks come with all of the user orientated features that you would expect from a Vango product along side branded zips and components for a perfectly versatile collection.

With our Hydration range carrying forward into 2018 you'll find our classic multi sport packs available for light & fast adventures.

# LYT NEW

Lyt by name and light by nature, this stunning little pack has real punch, with its simple and clean styling. The 420D Cationic Nylon, is nearly 4 times stronger than polyester and is extremely abrasion resistant. It also adds a great visual depth to the fabric making them really pop. With an extended zip to the main compartment it's quick and easy to access its contents while a stash pocket in the front keeps your essentials close to hand.

- AirForce Back System
- Airmesh on Harness
- Sternum Strap
- Hydration Compatible
- Excel® 420D Cationic Nylon
- Organisation Pocket
- Duraflex Buckles
- Reflective Print

## 20

**CAPACITY** 20 litres  
**WEIGHT** 420g  
**DIMENSIONS**  
L20 / W28 / H48cm  
**STD ORDER QTY** 5



**CARIBBEAN GREEN**  
RUNLYT G07026

- **VOLT BLUE**  
RUNLYT B09026
- **CARBIDE GREY**  
RUNLYT G10026 CORE

**15**  
**CAPACITY** 15 litres  
**WEIGHT** 360g  
**DIMENSIONS**  
L20 / W24 / H42cm  
**STD ORDER QTY** 5



**VOLT BLUE**  
RUNLYT B09015

- **CARIBBEAN GREEN**  
RUNLYT G07015
- **CARBIDE GREY**  
RUNLYT G10015 CORE

# STRYD NEW

Ergonomic in its design, the Stryd sits comfortably on the back leaving lots of room for shoulder and arm movement with its tear drop shape. Also, in using the AirForce back system, chest strap and sculpted shoulder straps, the Stryd has a snug fit which remains stable during activity.

- AirForce Back System
- Airmesh on Harness
- Sternum Strap
- Hydration Compatible
- Excel® 420D Cationic Nylon
- Twin Side Pockets
- Organisation Pocket
- Duraflex Buckles
- Reflective Print
- Elasticated side pockets

**22**  
**CAPACITY** 22 litres  
**WEIGHT** 540g  
**DIMENSIONS**  
L22 / W30 / H50cm  
**STD ORDER QTY** 5



CORE

**VOLT BLUE**  
RUNSTRYD B09030

- **CARBIDE GREY**  
RUNSTRYD G10030 CORE

## 26

**CAPACITY** 26 litres  
**WEIGHT** 600g  
**DIMENSIONS**  
L24 / W32 / H53cm  
**STD ORDER QTY** 5



**CARIBBEAN GREEN**  
RUNSTRYD G07038

- **VOLT BLUE**  
RUNSTRYD B09038
- **CARBIDE GREY**  
RUNSTRYD G10038 CORE

# FLUX NEW

The Flux is a pack born out of the love for adventure. It combines technical rucksack features designed for the great outdoors like walking pole attachments, hydration pack compatibility and the AirForce back system with the everyday convenience of an A4 compatibility, security clip and multiple internal and external pockets

- AirForce Back System
- Airmesh on Harness
- Sternum Strap
- Hydration Compatible
- Excel® 420D Cationic Nylon
- Twin Side Pockets
- Organisation Pocket
- Duraflex Buckles
- Reflective Print

**22**  
**CAPACITY** 22 litres  
**WEIGHT** 640g  
**DIMENSIONS**  
L23 / W30 / H49cm  
**STD ORDER QTY** 5



**CARBIDE GREY**  
RUNFLUX G10030

- **VOLT BLUE**  
RUNFLUX B09030



**28** HERO  
**CAPACITY** 28 litres  
**WEIGHT** 700g  
**DIMENSIONS**  
L25 / W34 / H53cm  
**STD ORDER QTY** 5



**VOLT BLUE**  
RUNFLUX B09042

- **CARBIDE GREY**  
RUNFLUX G10042 CORE

# FYR NEW

With its stunning good looks, the Fyr blends outdoor technical features with a sleek urban aesthetic. The 420D Cationic Nylon, is nearly 4 times stronger than polyester and is extremely abrasion resistant. It also adds a great visual depth to the new Carbide and Volt colours making them really stand out from the crowd. With a walking pole attachment points, detachable waist belt and mesh organiser pocket, Fyr is as at home on the hill as it is in the city.

- AirForce Back System
- Airmesh on Harness
- Sternum Strap
- Hydration Compatible
- Excel® 420D Cationic Nylon
- Walking Pole Attachments
- Twin Side Pockets
- Organisation Pocket
- Detachable Waist Belt
- Duraflex Buckles
- Reflective Print

## 25

**CAPACITY** 25 litres  
**WEIGHT** 580g  
**DIMENSIONS** L22 / W31 / H48cm  
**CARTON QTY** 10  
**STD ORDER QTY** 5



CARBIDE GREY  
 RUNFYR G10036

VOLT BLUE  
 RUNFYR B09036



## 30

**CAPACITY** 30 litres  
**WEIGHT** 640g  
**DIMENSIONS** L23 / W33 / H51cm  
**CARTON QTY** 10  
**STD ORDER QTY** 5



VOLT BLUE  
 RUNFYR B09046

CARBIDE GREY  
 RUNFYR G10046

# DRYFT NEW

A lightweight and versatile pack, the Dryft is a well designed multi use day sack, that is equally at home in town, as it is in the wilds. Constructed in a 420 denier Cationic Nylon, this rucksack combines stunning looks with a fabric durability that is over three times stronger than Polyester.

- AirForce Back System
- Airmesh on Harness
- Sternum Strap
- Hydration Compatible
- Excel® 420D Cationic Nylon
- Twin Side Pockets
- Organisation Pocket
- Detachable Waist Belt
- Front Stash Pocket
- Raincover

## 28

**CAPACITY** 28 litres  
**WEIGHT** 720g  
**DIMENSIONS** L22 / W34 / H52cm  
**CARTON QTY** 6  
**STD ORDER QTY** 5



CARBIDE GREY  
 RUNDRYFT G10042

VOLT BLUE  
 RUNDRYFT B09042



## 34

**CAPACITY** 34 litres  
**WEIGHT** 820g  
**DIMENSIONS** L24 / W36 / H55cm  
**CARTON QTY** 6  
**STD ORDER QTY** 5



VOLT BLUE  
 RUNDRYFT B09051

CARBIDE GREY  
 RUNDRYFT G10051

# SPRINT

The Sprint hydration rucksack is ideal for all sports enthusiasts. From trail runners to cyclists, users will appreciate this lightweight pack with 2L reservoir.

- Excel® 420D honeycomb polyester.
- 2L hydration reservoir included.
- AirMesh back system.
- Mesh ventilated shoulder straps.
- Sternum strap.
- Detachable waist belt.
- Front zip pocket with key clip.
- Shockcord accessory web.
- Reflective points.
- Dust/valve cover
- Key pocket

## 3

**CAPACITY** 3 litres

**WEIGHT** 400g

**DIMENSIONS**  
L5 / W22 / H39cm

**CARTON QTY** 10

**STD ORDER QTY** 5

BLACK ECLIPSE  
RUMSPRINTB5Z003



# SWIFT

The Swift is perfect for athletic activities, featuring an ergonomic hip belt with zip pockets. Its stylish and lightweight design coupled with a 2L reservoir make it the ideal pack for fast and light adventures.

- Excel® 420D honeycomb polyester.
- 2L hydration reservoir included.
- AirMesh back system.
- Sternum strap with emergency whistle.
- Ergonomic hip belt with zip pockets.
- Internal mesh pockets.
- Reflective light loop for clip-on light.
- Reflective points.

## 10

**CAPACITY** 10 litres

**WEIGHT** 560g

**DIMENSIONS**  
L17 / W20 / H40cm

**CARTON QTY** 10

**STD ORDER QTY** 5

BLACK ECLIPSE  
RUMSWIFTB5Z010



# RAPIDE

The Rapide comes complete with Vango's 2L Hydrant reservoir and is designed with a helmet compartment on the front of the pack, ideal for adventure racers and cyclists.

- Excel® 420D honeycomb polyester.
- 2L hydration reservoir included.
- AirForce back system.
- Sternum strap.
- Detachable rain cover.
- Detachable waist belt.
- Front stash pocket.
- Helmet 'stow' compartment.
- Side compression straps.
- Pro-weave side pockets.
- Reflective light loop for clip-on light.
- Reflective points.
- Dust/valve cover
- Key pocket

## 20

**CAPACITY** 20 litres

**WEIGHT** 750g

**DIMENSIONS**  
L28 / W24 / H46cm

**CARTON QTY** 10

**STD ORDER QTY** 5

BLACK ECLIPSE  
RUMRAPIDEB5Z026



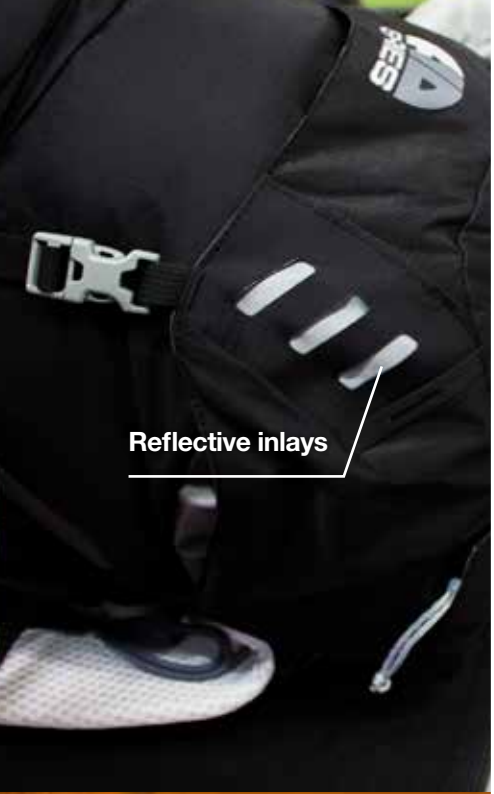

Reflective inlays

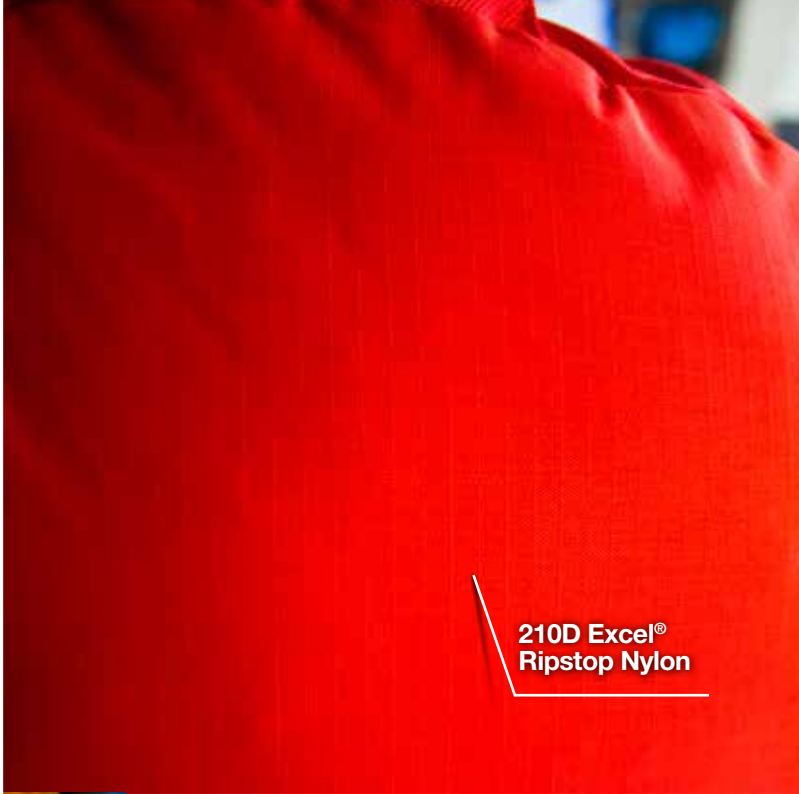

210D Excel® Ripstop Nylon



Duraflex® buckles

**RUCKSACKS**



Raincover with reflective detail

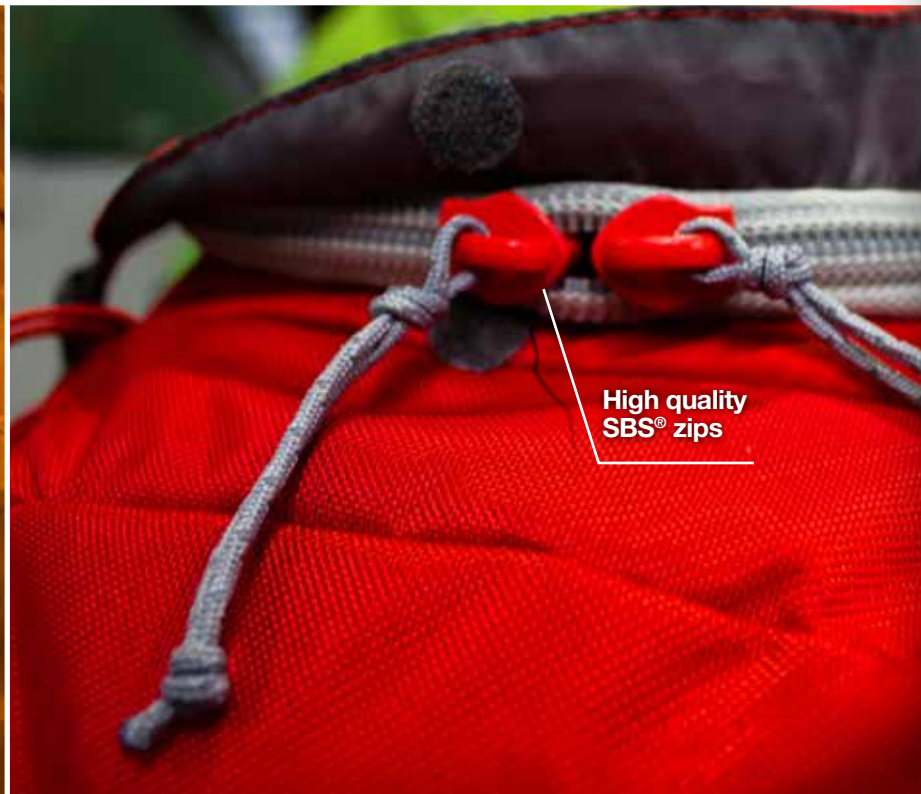

High quality SBS® zips

**ACTIVE PACKS**

Expanding on our existing collection of alpine inspired bags, the Active range for 2018 now encompasses everything from 17L day bags to multi day, multi activity rucksacks to take you to the peak of the Alps and beyond.

Crafted from high quality nylon and Cordura fabrics with Duraflex components and SBS zips, our F10 Series rucksacks are at the pinnacle of the packs we produce. Built around the users needs and sporting strong Chilli Red & Black colourways the new packs in the range look sharp and function no matter what you throw at them.

# CALDERA

Have gear to transport or store? Meet the F10 Caldera, your new favourite kit bag. Built tough, with multiple carrying options and attachment points, F10 Caldera is a must have for any outdoor enthusiast.

- 500 denier Cordura nylon fabric, with hydrostatic head of 1000mm
- Daisy chain allows accessory attachment
- High strength durable zips - Prevents water ingress
- Zip mesh pocket inside the lid - Allows easy storage and identification of contents
- Central grab handle - For easy carrying and moving
- Grab handles at both ends - Easy to move and carry
- Duraflex components - Strong and reliable

## 40

**CAPACITY** 40 litres  
**WEIGHT** 920g  
**DIMENSIONS** L55 / W30 / H30cm  
**STD ORDER QTY** 1

## 60

**CAPACITY** 60 litres  
**WEIGHT** 1.08kg  
**DIMENSIONS** L68 / W31 / H31cm  
**STD ORDER QTY** 1

F10 ORANGE  
RUMCALDERF51RE7



F10 ORANGE  
RUMCALDERF51RE8



F10 ORANGE  
RUMCALDERF51RE9



## 100

**CAPACITY** 100 litres  
**WEIGHT** 1.5kg  
**DIMENSIONS** L78 / W40 / H40cm  
**STD ORDER QTY** 1



F10 ORANGE  
RUMCALDERF51P68

# V17



The F10 V17 pack combines ergonomic shape and functionality in a lightweight rucksack. Ideal for multi-sport adventurers, the AlpFlex back moves with the body whilst allowing air to flow.

- Alp-Flex Back System
- Rain cover
- Reflective Panels
- Detachable Waist Belt
- SBS Zips
- Excel® 210D Ripstop Nylon
- Interior Mesh Pockets
- Pro-Weave Side Pockets
- Hydration Compatible
- Walking Pole / Ice Axe Attachments
- Duraflex Buckles

## 17

**CAPACITY** 17 litres  
**WEIGHT** 600g  
**DIMENSIONS** L25 / W26 / H45cm  
**STD ORDER QTY** 1



CHILLI RED  
RUNV17 C46019

BLACK  
RUNV17 B05019



# ALPLITE

For those seeking a super lightweight sack for technical accents, the F10 Alplite is built on the foundation of the award winning and widely applauded F10 Alpine. Featuring the same customisable and minimalistic approach F10 Alplite utilises a lighter body 210D ripstop nylon fabric for fast and light trips.

- Number 10 Zips
- Moulded Back Panel
- Accessory Pack
- Elastic and cord adjusters for attaching sleep mat
- Excel® 210D Double Line Ripstop Nylon
- Webbing Hip Belt
- Adjustable chest strap
- Access Zip
- Top Lid with Zippered Pocket
- Key Clip Inside Pocket
- Internal Pocket
- Daisy Chains
- Axe Attachments
- Rope Strap
- Compression Straps
- Ski Straps
- Duraflex components



## 35

**CAPACITY** 35 litres  
**WEIGHT** 900g  
**DIMENSIONS** L17 / W28 / H60cm  
**CARTON QTY** 5  
**STD ORDER QTY** 1



BLACK  
35 RUMALPLITB05052  
45 RUMALPLITB05060

## 45

**CAPACITY** 45 litres  
**WEIGHT** 1.16kg  
**DIMENSIONS** L18 / W30 / H64cm  
**CARTON QTY** 5  
**STD ORDER QTY** 1

# GR NEW HERO

Ideally suited to those taking part in short, lightweight overnight hikes or winter walks. The F10 GR has been designed to combine the simplicity of a climbing pack, with the functionality of a more sophisticated trekking rucksack. Constructed in a lightweight 210 denier nylon with ripstop, the F10 GR features a specially designed back system allowing the user to adjust the back length, in order to provide a customised fit. This backpack has a traditional top entry point, but it also has a clam shell front, which provides much greater access to the whole pack, making it easier to reach items located in the middle or bottom. With axe/pole attachment points, large elasticated drop in pocket on the main face (ideal for additional quick-to-reach clothing) and a floating lid, the F10 GR will keep gear in order, even in the bleakest of conditions.

- **Alp-Fit Back System** - Adjustable via a secure hook & loop system.
- **Airmesh on harness and rucksack straps** - Allows air to flow
- **Ergonomic padded hip belt** - Shaped for optimum load transfer and comfort
- **Floating Lid** - Expand capacity when carrying larger loads
- **Clamshell Opening** - Zipped access via the front of the pack
- **Extendable Gaiter Under Lid** - Provides additional pack space and protection
- **Rain cover** - Waterproof rain cover with reflective print.
- **Reflective Panels** - Laser cut, highly reflective panels for added visibility
- **Dual Side Compression Straps** - Stabilise rucksack contents
- **SBS Zips** - High quality, durable zips
- **Excel® 210D Ripstop Nylon** - exceptionally high quality polyamide; lightweight, strong and durable with a double ripstop weave for additional tear-proof strength
- **Pro-weave side pockets** - Constructed from highly durable, yet extremely flexible material

## 35:40

**CAPACITY** 40 litres  
**WEIGHT** 1.44kg  
**DIMENSIONS**  
 L30 / W27 / H64cm  
**CARTON QTY** 5  
**STD ORDER QTY** 1

CHILLI RED

35:40 RUNGR C46R1F



## 45:50

**CAPACITY** 50 litres  
**WEIGHT** 1.48kg  
**DIMENSIONS**  
 L31 / W30 / H66cm  
**CARTON QTY** 5  
**STD ORDER QTY** 1

BLACK

45:50 RUNGR B05R1G



# HUT NEW

Inspired by the Alpine tradition of trekking using mountain huts for refuge (Bothying in the UK), this all season rucksack is ideal for day hikes or shorter multi-night trips. The F10 Hut is fitted with the innovative Air Adjust back system, which uniquely combines the benefit of a ventilated suspended air frame with full adjustability, which allows the user to change the back length to provide a perfectly customised fit. The sculpted shoulder straps and hip support distribute weight effectively and because its constructed in 210D ripstop nylon fabric, it is both lightweight and highly durable. This pack also features a zip down lid, which extends down the length of the bag, making it easy to access any part of the rucksack. The F10 Hut is the ideal backpack for those exploring the wilds of our planet.

- **Alp-Adjust Back System** - vented back system allows the user to adjust the harness to fit
- **Airmesh on harness and rucksack straps** - Allows air to flow
- **Ergonomic padded hip belt** - Shaped for optimum load transfer and comfort
- **Deep zip main compartment** - A much larger zip opening for easier access the main compartment
- **Rain cover** - Waterproof rain cover with reflective print.
- **Reflective Panels** - Laser cut, highly reflective panels for added visibility
- **Dual Side Compression Straps** - Stabilise rucksack contents
- **SBS Zips** - High quality, durable zips
- **Excel® 210D Ripstop Nylon** - exceptionally high quality polyamide; lightweight, strong and durable with a double ripstop weave for additional tear-proof strength when empty. Allows easy access to essential items

## 35

**CAPACITY** 35 litres  
**WEIGHT** 1.78kg  
**DIMENSIONS**  
 L31 / W35 / H66cm  
**CARTON QTY** 5  
**STD ORDER QTY** 1



CHILLI RED

RUNHUT C46052

## 45

**CAPACITY** 45 litres  
**WEIGHT** 1.84kg  
**DIMENSIONS**  
 L32 / W37 / H67cm  
**CARTON QTY** 5  
**STD ORDER QTY** 1



BLACK

RUNHUT B05060



Carefully designed, comfortable backsystems

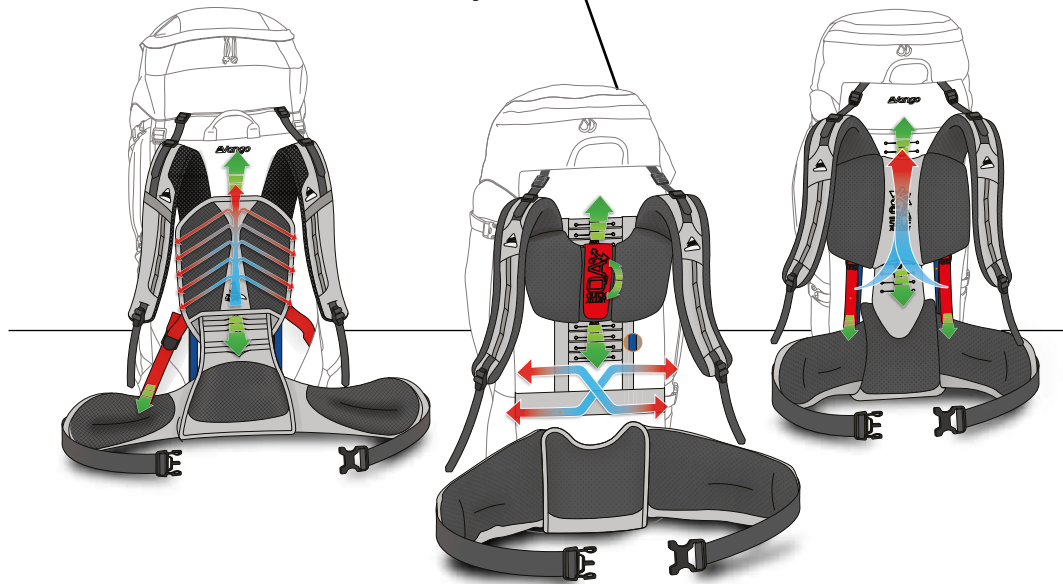

Backsystems in use:



## RUCKSACKS



Duraflex® buckles



Striking colourways  
stand out on the hill

## TREKKING PACKS

From the Pathfinder to our F10 Series, we have expanded our Trekking range for 2018 to offer the perfect pack for everyone from those who are quite literally taking their first steps in the outdoors to others covering thousands of kilometres of trail on long term excursions.

Featuring long term favourites like the Contour and Sherpa plus new heroes in the form of our TMB & PCT packs; the trekking range has never offered such a strong proposition for our varied consumers.

The collection reflects decades of knowledge and expertise combined to produce our comprehensive range of larger packs for long, kit heavy excursions and youth group awards whether that's on UK soil or further afield.

# PATHFINDER



New for 2018 the Pathfinder backpack is an excellent all rounder that uses a simple size tolerant back system to balance and spread the load, making it a comfortable multi-day trekking pack. This affordable 55L rucksack comes with top and bottom access points; mesh pockets and twin daisy chains to provide high levels of flexibility. Recommended by The Scouts Association the Pathfinder is ideally suited for people taking part in their first multi-day hikes.

## 55

**CAPACITY** 55 litres  
**WEIGHT** 1.64kg  
**DIMENSIONS** L29 / W32 / H73cm  
**CARTON QTY** 5  
**STD ORDER QTY** 5

- 420D Diamond Polyester
- Size tolerant back system - Simple, robust carry system that has the same load carrying abilities as our adjustable rucksacks. Shaped back creates a chimney effect that encourages ventilation during activity
- Duraflex buckles - Strong and reliable
- Twin side pockets - Allows quick access to items needed whilst trekking
- Side Compression Straps - to secure your load
- Dual side compression straps - Stabilise rucksack contents
- Ergonomic padded hip belt - Shaped for optimum load transfer and comfort
- Compatible with most hydration reservoirs
- Webbing grab handle between shoulder straps



**COBALT BLUE**  
RUNPATHFIC17064

## 65

**CAPACITY** 65 litres  
**WEIGHT** 1.76kg  
**DIMENSIONS** L29 / W32 / H85cm  
**CARTON QTY** 5  
**STD ORDER QTY** 5

CORE



**SHADOW BLACK**  
RUNPATHFIB05066

**COBALT BLUE**  
RUNPATHFIC17066

# CONTOUR



Designed for backpackers and explorers heading out on multi night expeditions, the Contour offers exceptional performance and fit. Recommended by DofE and Scouts, because of its brilliantly designed QuickAdjust back system, this rucksack allows the user customise for a perfect fit on wide range of back lengths.

- Excel® 420D honeycomb polyester / Excel® 600D polyester.
- QA - QuickAdjust back system.
- Top lid access with extendable gaiter.
- Pro-weave side pockets.
- Shaped adjustable harness.
- Shoulder fit guide - indicates correctly adjusted rucksack harness.
- Ergonomic padded hip belt.
- Additional zip pocket under lid.
- Rain cover
- Expansion side zip pockets.
- Detachable rain cover included.
- Hydration compatible.
- Dual side compression straps.
- Sternum strap with emergency whistle.
- Ice axe/walking pole attachment points.
- Reflective points.
- Webbing grab handle.
- Duraflex® components.

## 50:60S

**CAPACITY** 60 litres  
**WEIGHT** 2.30kg  
**DIMENSIONS** L27 / W28 / H78cm  
**BACK SIZE RANGE** 46-56cm  
**CARTON QTY** 5  
**STD ORDER QTY** 5



**BLACK**  
 RUNCONTOUB05R1H

**COBALT BLUE**  
 RUNCONTOUC17R1H



## 60:70

**CAPACITY** 70 litres  
**WEIGHT** 2.45kg  
**DIMENSIONS** L28 / W27 / H73cm  
**BACK SIZE RANGE** 50-60cm  
**CARTON QTY** 5  
**STD ORDER QTY** 5



**PAPRIKA**  
 RUNCONTOUP13R11



**SHADOW BLACK**  
 RUNCONTOUB05R11



**COBALT**  
 RUNCONTOUC17R11

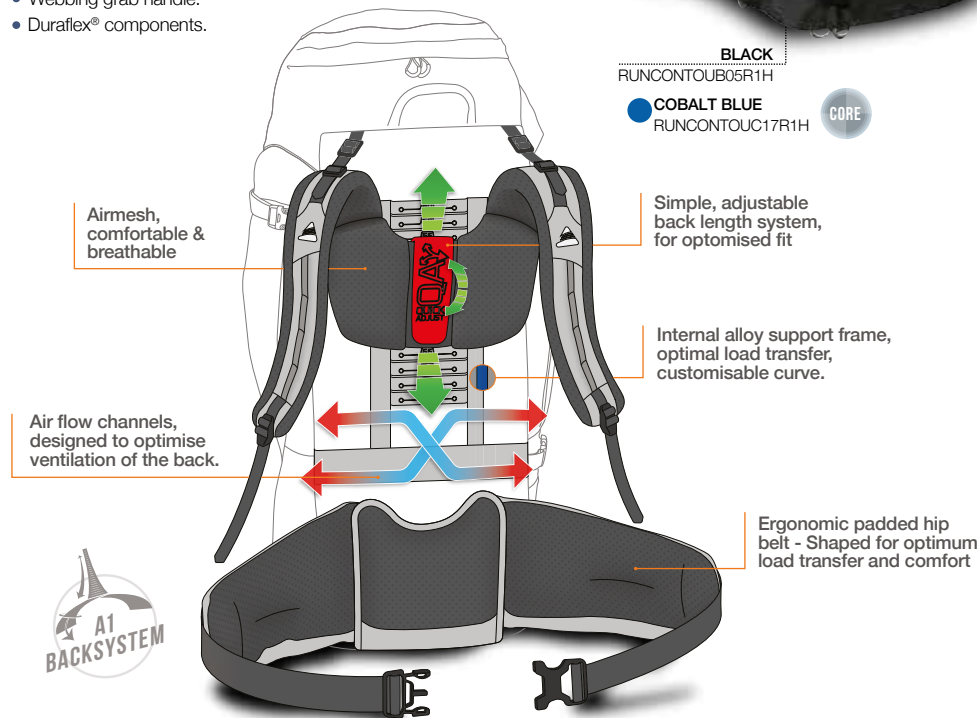

# SHERPA



The Sherpa is fully equipped with the Self Adjust back system, durable components and clever features giving an edge when it comes to efficient load control and performance. Sherpa is an all-round rucksack recommended by the DofE and Scouts. Ideal for multi-day treks and activity.

- Excel® 420D honeycomb polyester / Excel® 600D polyester.
- SA - Self-Adjust back system.
- Shaped adjustable harness.
- Drawcord compartment divider.
- Daisy chain accessory attachment.
- Top lid with zip pocket.
- Dual side compression straps.
- Additional zip pocket under lid.
- Expansion side zip pockets.
- Water resistant zipped compartment.
- Pro-weave side pockets.
- Ergonomic padded hip belt with water resistant pocket.
- Detachable rain cover included.
- Ice axe/walking pole attachment points.
- Shoulder fit guide - indicates correctly adjusted harness.
- Hydration compatible.
- Top and side grab handles.
- Sternum strap with emergency whistle.
- Reflective points.
- Dual access points.
- Duraflex® components.v

## 60:70S

**CAPACITY** 70 litres  
**WEIGHT** 2.38kg  
**DIMENSIONS** L25 / W36 / H76cm  
**CARTON QTY** 5  
**STD ORDER QTY** 5



**COBALT BLUE**  
 RUNSHERPAC17R1K

## 65

**CAPACITY** 65 litres  
**WEIGHT** 2.35kg  
**DIMENSIONS** L23 / W42 / H76cm  
**CARTON QTY** 5  
**STD ORDER QTY** 5



**SHADOW BLACK**  
 RUNSHERPAB05066

**COBALT BLUE**  
 RUNSHERPAC17066

**SHADOW BLACK**  
 RUNSHERPAB05R11

## 60:70

**CAPACITY** 70 litres  
**WEIGHT** 2.40kg  
**DIMENSIONS** L25 / W36 / H76cm  
**CARTON QTY** 5  
**STD ORDER QTY** 5



**PAPRIKA**  
 RUNSHERPAP13R11

## 70:80

**CAPACITY** 80 litres  
**WEIGHT** 2.60kg  
**DIMENSIONS** L25 / W37 / H82cm  
**CARTON QTY** 5  
**STD ORDER QTY** 5



**SHADOW BLACK**  
 RUNSHERPAB05R1J

**COBALT BLUE**  
 RUNSHERPAC17R11

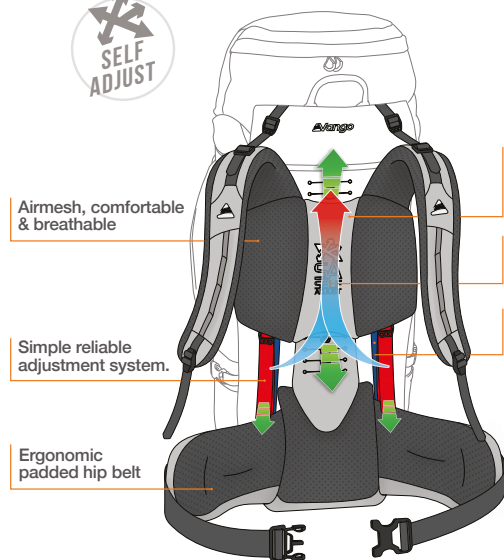

Airmesh, comfortable & breathable

Simple reliable adjustment system.

Ergonomic padded hip belt

Simple, adjustable back length system, for optimised fit

Air flow channels, designed to optimise ventilation of the back.

Alloy support frame, optimal load transfer, customisable curve.

# PINNACLE



Part of our Vango Trekking collection of Rucksacks, the Pinnacle 70:10 is ideal for those who are heading out on longer excursions. The Pinnacle offers outstanding performance and fit due to the new A1 back system. Designed for fast and easy adjustment this back system allows you to customise fit with one hand, in one single movement and whilst still wearing the pack. This year-round trekking rucksack's front opening section guarantees that you will be able to get to all of your belongings even in a small trekking tent.

- Single Adjust Back System (A1) - adjusted with one hand to fit almost any back length perfectly
- Ergonomic hip belt with zipped pockets - Shaped for comfort with quick, convenient storage of small items
- Floating lid - Expand capacity when carrying larger loads
- Zip access to main compartment - provides quick access to pack contents
- Extendable gaiter
- Side Compression Straps
- Dual access points
- Top Compression Straps - for compressing your load and strapping items underneath
- Excel® 420D Honeycomb Polyester - offers great strength to weight ratio
- Front stash pocket - Store items for quick access
- Ice Axe/Walking Pole Attachments
- Pro-weave side pockets
- Expansion side zip pockets
- Detachable rain cover
- Hydration compatible
- Daisy chain
- Reflective Points
- Duraflex buckles

## 60:70

**CAPACITY** 70 litres  
**WEIGHT** 2.74kg  
**DIMENSIONS** L25 / W36 / H76cm  
**CARTON QTY** 5  
**STD ORDER QTY** 5



**SHADOW BLACK**  
 RUNPINNACB05R11

## 70:80

**CAPACITY** 80 litres  
**WEIGHT** 2.80kg  
**DIMENSIONS** L28 / W35 / H88cm  
**CARTON QTY** 5  
**STD ORDER QTY** 5



**COBALT**  
 RUNPINNACC17R1J

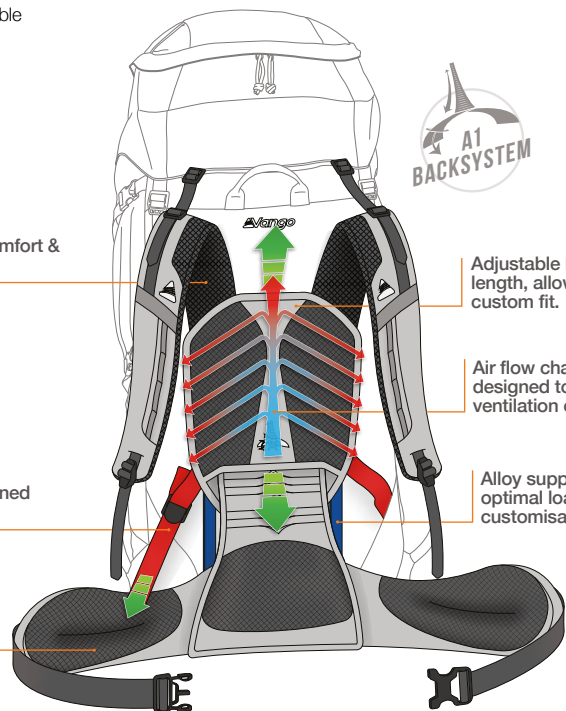

3D Airmesh, maximum comfort & airflow.

Adjustable back length, allows for custom fit.

Air flow channels, designed to optimise ventilation of the back.

Single hand adjust, ergonomically designed for ease of use.

Alloy support frame, optimal load transfer, customisable curve.

Ergonomically shaped, high density foam hip belt

# F10 TMB



TMB is an exceptional multi day pack born out of years leading the field in trekking rucksacks. Named after the world famous Tour De Mont Blanc, this pack has been engineered to provide fantastic stability and load balance through the very clever A1 back system, which provides the ultimate in adjustability and customised fit. Extremely well ventilated, the TMB will help keep the hiker dry in even the hottest conditions and, as a result of the super strong 210D Nylon Ripstop, it is also a backpack built to take whatever punishment the great outdoors can throw at it. As should be expected from F10, the TMB comes loaded with a wide range of features including bottom of pack access, multiple rigging points and a huge array of pockets. This is a fully featured pack, designed for those with a healthy sense of adventure.

- A1 - Single Adjust Back System - Single Adjust Back System (A1) - An evolution of our Self Adjust back system. Built around two body contoured alloy bars, the back system can adjusted with one hand to fit almost any back length perfectly, whilst still wearing the pack.
- Ergonomic Padded Hip Belt - Shaped for optimum load transfer and comfort
- 3D Ergonomic Hip Belt - Shaped for optimum comfort and load carrying
- Shaped Adjustable Harness - Provides optimum fit and comfort
- Rain cover - Waterproof rain cover with reflective print.
- Daisy Chains - allows accessory attachment
- Dual Side Compression Straps - Stabilise rucksack contents
- Dual Access Points - 2 entry points for easy access to contents
- SBS Zips - High quality, durable zips
- Additional Zip Pocket Under lid opening - Safe storage for small items
- Expansion Side Zip Pockets - Slim profile pack with extra storage capacity when required
- Pro-Weave Side Pockets - Constructed from highly durable, yet extremely flexible material. Pockets sit flush with the pack when empty. Allows easy access to essential items
- Walking Pole / Ice Axe Attachments - For carrying essential safety gear
- Airmesh on Harness - Allows air to flow, keeping the user cool
- Reflective Tabs - aid visibility in poor weather or at night
- Duraflex Buckles - Strong and reliable

**60:70**

**CAPACITY** 70 litres

**WEIGHT** 2.00kg

**DIMENSIONS**  
L25 / W36 / H76cm

**CARTON QTY** 5

**STD ORDER QTY** 5



BLACK  
RUNTMB B05R11

# PCT NEW

The F10 PCT is the ultimate in multi daypacks, be it for a few days wild camping, months of intercontinental travel or exploration to the wildest regions of our planet. The Pacific Crest Trail (PCT) was the inspiration behind this rucksack, which has been designed to provide the very best in technical advances that makes carrying weighted loads more comfortable and safer. The A1 back system has been engineered to provide fantastic stability and load balance whilst, at the same time, it is well ventilated keeping the hiker dry in even the hottest conditions. Built using a lightweight, but super strong, 210D Nylon Ripstop it is also a backpack built to take whatever punishment is thrown at it. This rucksack also comes with a very clever clam-shell opening system, which allows the user to open up the pack right down its main face, giving much easier access to any part of the bag. So no more reaching around, feeling and yanking out from the top of the pack, simply zip it open to find what you're looking for. The PCT comes loaded with a wide range of features including rain cover, customisable rigging points and a huge array of pockets. This is a fully featured pack, designed for true adventurers.

- A1 - Single Adjust Back System
- 3D Ergonomic Hip Belt
- Clamshell Opening
- Shaped Adjustable Harness
- Excel® 210D Ripstop Nylon
- Rain cover
- Reflective Panels
- Floating Lid
- Side Compression Straps
- Daisy Chains
- Extendable Gaiter Under Lid
- Top Lid with Zippered Pocket
- Dual Side Compression Straps
- SBS Zips
- Additional Zip Pocket Under Lid opening
- Expansion Side Zip Pockets
- Walking Pole / Ice Axe Attachments
- Airmesh on Harness
- Hydration Compatible
- Grab Handle
- Top Compression Straps
- Duraflex Buckles

## 50:60S

**CAPACITY** 60 litres  
**WEIGHT** 2.24kg  
**DIMENSIONS** L30 / W30 / H76cm  
**CARTON QTY** 5  
**STD ORDER QTY** 5



CHILLI RED  
 RUNPCT R03R1H

## 60:70

**CAPACITY** 70 litres  
**WEIGHT** 2.36kg  
**DIMENSIONS** L31 / W30 / H84cm  
**CARTON QTY** 5  
**STD ORDER QTY** 5



BLACK  
 RUNPCT B05R1I

# RUCKSACK ESSENTIALS

## HYDRANT 2L

RUMHYPACKZ01Z01

The Vango Hydrant Pack is ideal for those on the go, providing easy access to water and with securely locking sealable closure. The Hydrant Pack is made from strong, durable TPU material which is BPA free, no chance of leaks or wet kit. While the oversized full top opening ensures it is easy to clean.

- Fits the back panel of any pack.
- TPU (Thermo Plastic Polyurethane) is strong and abrasion resistant.
- BPA free – (Bisphenol A).
- Quick-release hose and shut-off valve make drinking and re-filling easy.

**CAPACITY** 2 litres  
**WEIGHT** 140g  
**STD ORDER QTY** 1



## DRY BAG

The Vango dry bag is perfect for lining your rucksack on trips where it is likely to get wet, and keeping items separated and dry inside larger bags. The roll top closure system effectively seals the bag against any encroaching water, making it ideal for cycling, kayaking and wet weather trekking activities.

- Lightweight, high quality fasteners with Hypalon webbing.
- Roll top dry bag - expel excess air and roll 3 times for a sealed, water tight bag.

**30**  
**CAPACITY** 30 litres  
**SIZE** H50 x WØ29CM  
**WEIGHT** 80g  
**STD ORDER QTY** 5



**ORANGE**  
RUMDRYBAGO07046

## DRY BAG SET

RUMDRYBAGAS5Z23

The Vango Dry Bag Set offers a variety of sizes to protect all your essentials when trekking, cycling, kayaking, climbing, commuting or travelling. An indispensable companion for the wet and wild outdoors!

- Lightweight, high quality fasteners with Hypalon webbing.
- Roll top dry bag - expel excess air and roll 3 times for a sealed, water tight bag.



**60**  
**CAPACITY** 60 litres  
**SIZE** H70 x WØ33CM  
**WEIGHT** 100g  
**STD ORDER QTY** 5



**GREEN**  
RUMDRYBAGG07065

### SMALL

**CAPACITY** 2 litres  
**SIZE** H28 x W24cm  
**WEIGHT** 30g

### LARGE

**CAPACITY** 16 litres  
**SIZE** H32 x WØ25cm  
**WEIGHT** 55g

### MEDIUM

**CAPACITY** 6 litres  
**SIZE** H30 x WØ16cm  
**WEIGHT** 38g

**STD ORDER QTY** 5

## MESH BAG SET

RUMMESHBAZ03Z05

Keep your equipment tidy and organized with the multi-color mesh set.

**WEIGHT** 230g  
**STD ORDER QTY** 5



## UNIVERSAL HIP POUCH



RUNACCESSH79Z05

The ideal accessory to any of our trekking rucksacks, just slide it onto the hip belt and you have additional small storage pockets.

**WEIGHT** 100g  
**STD ORDER QTY** 5



## RAIN COVER

Lightweight protection from the rain for your rucksack. The perfect companion on your adventures.

- Polyester PU coated body.
- Bright orange with silver logo.



**SMALL** RUMRAINCOV07CL2  
**SIZED FOR 25-36 LITRE PACKS**  
**STD ORDER QTY** 10

**MEDIUM** RUMRAINCOV07CL3  
**SIZED FOR 40-55 LITRE PACKS**  
**STD ORDER QTY** 10

**LARGE** RUMRAINCOV07B57  
**SIZED FOR 60+ LITRE PACKS**  
**STD ORDER QTY** 10



# FOOTWEAR

*We understand feet.*

*Our footwear is designed, tested, and developed in Scotland led by Gordon Fraser, then hand made by our partners in Europe.*

*We don't underestimate the importance of fit for long days on the trail, which is why we have created the unique Vango Footwear System. Central to this is our "Millennium" last, a contemporary European shape built with laser focus on absolute comfort and performance, with a modern asymmetric fit that will be universally accepted. We also introduce Vango FlexBeam, a calibrated polycarbonate chassis for each size, ensuring the wearer, no matter their foot size, gets the right flex they need for walking, hiking and trekking. The chassis system also includes polyurethane midsoles, for long lasting comfort, shock absorption and energy return when the trail gets tough. Finally, the Vango FootSpy insole and FitStick tool make ensuring the perfect fit instore a walk in the park, through easy safe zone markings.*

*Of course, testing in Scotland proves the value of our ProTex waterproof membrane, so it's featured throughout the range. Also look out for our Rock Rubber protection and the new Easy Glide lacing system.*

*All Vango footwear is with The Duke of Edinburgh Award for testing and approval.*

*Our goal is happy and relaxed feet after long days on the trail... We're confident it's been achieved...*



Vango FlexBeam System® - is a calibrated chassis for each size ensuring every wearer, no matter their foot size, will get the flex they need for the type of walking, hiking and trekking they are doing. Our calibrated chassis system is also designed to protect the sole of the foot from stones and potential bruising when the terrain gets serious. Our goal is happy and relaxed feet after a long day on the trail.



People say the 'devil is in the detail' and that is how we have approached the design of our new Vango footwear collection. We have thought of absolutely everything.

Our Last shape is designed with a laser-focus on absolute comfort and performance.

Nothing more.



Lorem ipsum dolor sit amet, consectetur adipiscing elit, sed diam nonummy nibh euismod tincidunt ut laoreet dolore magna aliquam erat volutpat. Ut wisi enim ad minim veniam, quis nostrud exerci tation ullamcorper suscipit lobortis nisl ut aliquip ex ea commodo consequat. Duis autem vel eum iriure dolor in hendrerit in vulputate velit esse molestie consequat.

# VANGO FOOTWEAR NEW

## VELAN

Getting psyched-up to get out on the trail when the weather's against you can be tough. You need to rely on good, comfortable performance footwear. The lightweight Vango Velan boot with the Protex® waterproof and breathable membrane makes it a lot easier to get fired-up and get the legs moving. It's light, tough and comfortable. The cushioned midsole and unique FlexBeam Chassis™ help to ensure your knees don't take all the pounding and your feet feel less fatigued at the end of a long day.

- Upper: Fabric, Suede, Rubber Toe Bumper and Achilles Heel Lock
- Lacing System: Vango Ultra-Glide™
- Membrane: Protex®
- Lining: Open cell soft touch polyester
- Last shape: Millenium Men's
- Insole: Vango FootSpy Insole™
- Midsole: Cushioned PU
- Chassis: Vango Flexbeam System™
- Outsole: Rock Rubber®
- Weight: 477g (size 42 half pair)
- Designed in Scotland. Made in Europe

**SIZE RANGE** 41 – 47

**CARTON QTY** 1 pair

### PERFECT FOR

Day walks and low level hiking  
Overnight trips  
Mixed trail conditions



**Vango**  
FLEXBEAMSYSTEM™

## VELAN W

- Women's specific design and millenium last fir for comfort and performance
- Upper: Fabric and Suede with Achilles Heel-Lock
- Lacing System: Classic Eyelet
- Membrane: Protex®
- Lining: Open cell polyester
- Last Shape: Millenium Women's
- Insole: Vango FootSpy Insole™
- Midsole: Cushioned PU.
- Chassis: Vango Flexbeam System™
- Outsole: Rock Rubber®
- Weight: 360g (size 38 half pair)
- Designed in Scotland. Made in Europe

**SIZE RANGE** 36 – 42

**CARTON QTY** 1 pair

### PERFECT FOR

Day walks and low level hiking  
Overnight trips  
Mixed trail conditions



**Vango**  
FLEXBEAMSYSTEM™

## GRIVOLA

The Vango Grivola boot is designed to be slightly higher for greater protection and stability on more difficult terrain.

No matter what terrain you encounter on the trail, the Vango Grivola will keep up with your pace. The rugged upper is waterproof and lined with the fully-taped Protex® waterproof and breathable membrane, so trekking through water doesn't create uncomfortable, soggy feet.

- Upper: Fabric, Suede, Rubber Toe Bumper and Achilles Heel Lock
- Lacing System: Vango Ultra-Glide™
- Membrane: Protex®
- Lining: Open cell polyester
- Last shape: Men's
- Insole: Vango FootSpy Insole™
- Midsole: Cushioned PU
- Chassis: Vango Flexbeam System™
- Outsole: Rock Rubber®
- Weight: 459g (size 42 half pair)
- Designed in Scotland. Made in Europe

**SIZE RANGE** 41 – 47

**CARTON QTY** 1 pair

### PERFECT FOR

Hiking  
Backpacking  
Mixed trail conditions



**Vango**  
FLEXBEAMSYSTEM™

## GRIVOLA W

- Women's specific design and millenium last fir for comfort and performance
- Upper: Fabric, Suede and Rubber Toe Bumper
- Lacing System: Vango Ergo-Fit™
- Membrane: Protex®
- Lining: Open cell polyester
- Last shape: Men's
- Insole: Vango FootSpy Insole™
- Midsole: Cushioned PU
- Chassis: Vango Flexbeam System™
- Outsole: Rock Rubber®
- Weight: 410g (size 38 half pair)
- Designed in Scotland. Made in Europe

**SIZE RANGE** 36 - 42

**CARTON QTY** 1 pair

### PERFECT FOR

Hiking  
Backpacking  
Mixed trail conditions



**Vango**  
FLEXBEAMSYSTEM™

## CERVINO

Vango is proud to introduce its lightest and most feature packed backpacking boot in the Men's lightweight Cervino boot. The Cervino provides excellent fit and a rockered toe for less fatigue when you hike for miles with a heavy backpack. The tough fabric and suede upper features Protex® to protect your foot from the elements. Its dual-density midsole keeps your foot comfortable from the moment you take these boots out of the box.

- Upper: Fabric, Suede and Rubber Toe Bumper
- Lacing System: Vango Ergo-Fit™
- Membrane: Protex®
- Lining: Open cell soft touch polyester
- Last shape: Millenium Men's
- Insole: Vango FootSpy Insole™
- Midsole: Cushioned PU
- Chassis: Vango Flexbeam System™
- Outsole: Rock Rubber®
- Weight: 479g (size 42 half pair)
- Designed in Scotland. Made in Europe

**SIZE RANGE** 41 – 47

**CARTON QTY** 1 pair

### PERFECT FOR

Multi-day trekking  
Backpacking  
Mixed trail conditions



**Vango**  
FLEXBEAM SYSTEM™

## CERVINO W

- Upper: Fabric, Suede and Rubber Toe Bumper
- Lacing System: Vango Ergo-Fit™
- Membrane: Protex®
- Lining: Open cell soft touch polyester
- Last shape: Millenium Woman's
- Insole: Vango FootSpy Insole™
- Midsole: Cushioned PU
- Chassis: Vango Flexbeam System™
- Outsole: Rock Rubber®
- Weight: 410g (size 38 half pair)
- Designed in Scotland. Made in Europe

**SIZE RANGE** 36 – 42

**CARTON QTY** 1 pair

### PERFECT FOR

Multi-day trekking  
Backpacking  
Mixed trail conditions



**Vango**  
FLEXBEAM SYSTEM™

# VANGO WARRANTY

We work with our retail partners to manage all warranty repairs, and it is important that the sales contract (between you and the retailer you purchased your product from) remains valid, throughout any warranty claim. If you believe your product is a warranty claim, please initially contact the retailer from whom you purchased the product and they will advise you of the most appropriate course of action. Should your retailer decide that your product needs to be returned to us for inspection, they will return the product on your behalf. The more detail you can provide, the quicker and more accurate we can be in our response.

Products must be returned for inspection clean and dry. Any products received in an unsatisfactory condition may be returned to the sender without inspection.

If you bought your product from Vango.co.uk and are unsure which retailer supplied the product, please contact our retail service provider, Kibo, on 01793 461650.

This warranty covers the functionality of the product for its normal, intended use as specified in the consumer literature or website. It does not cover a malfunction that has resulted from improper or unreasonable use or maintenance, accidents, damage due to excessive winds/weather, improper re-packing or natural degradation due to sunlight.

The standard Vango warranty lasts for one year on footwear, and for 2016 collection onwards, this has been increased to two years on all other product ranges from date of purchase.

Register your Vango products with us and receive an extra 1 year warranty!\* Extend your warranty by a further year (excludes footwear), by registering your product; this may vary depending on the statutes in force within the country of purchase. Register your Vango product here.

Please note, the additional warranty does not apply to second hand products, or refurbished products and samples sold through sites such as Nearly New Tents.

\*Products must be registered within 6 months from date of purchase.

Please retain your original receipt, as proof of purchase will be required to authorise an extended warranty claim.

As a guide, the following damage is not covered under warranty:

## TENTS / AWNINGS

General wear and tear over extended periods of use

Flaws in the fabric caused by excessive wear

Water ingress through fabric as a result of UV degradation

Water ingress through seams caused by excessive abrasion of seams or seam sealant tape

Broken zips caused by forcing, jamming or improper use

Over tensioned/stretched seams coming apart

Buckles subjected to undue force or abrasion

Broken carry/roller bag if they are over loaded, used for carrying other items or used as a toy

Any pole breakages/beam punctures, these are treated as "fair wear and tear".

Collateral damage from a pole breakages/beam punctures

UV degradation

Condensation, usually caused by lack of ventilation

Commercial use by rental companies (Youth organisations, outdoor centres and non-commercial groups are governed by our standard warranty terms. Commercial use by rental companies is not covered by our user warranty)

## SLEEPING BAGS

General wear and tear over extended use

Flaws in the fabric caused by excessive wear

Broken zips caused by forcing, jamming or improper use

Over stretched seams coming apart

Buckles subjected to undue force or abrasion

Draw cord pulled out with excessive force

Broken stuff bag due to undue force

Reduced loft of filling

Commercial use by rental companies

(Youth organisations, outdoor centres and non-commercial groups are governed by our standard warranty terms. Commercial use by rental companies is not covered by our user warranty)

## RUCKSACKS

General wear and tear over extended use

Flaws in the fabric caused by excessive wear

Water ingress through seams (rucksack seams are not taped, a rucksack liner should be used)

Broken zips caused by forcing, jamming or improper use

Overloaded, tensioned or stretched seams coming apart

Buckles subjected to undue force or abrasion

UV degradation

Frame exposed through fabric through being dragged or dropped on rough ground

Commercial use by rental companies

(Youth organisations, outdoor centres and non-commercial groups are governed by our standard warranty terms. Commercial use by rental companies is not covered by our user warranty)

# TERMS & CONDITIONS

## Terms and Conditions

1. THE PARTIES: The expression 'AMG' shall mean AMG Group Ltd. The expression 'Customer' shall mean the person, firm or company contracting for the purchase of goods from AMG Group Ltd.
2. WHOLE TERMS: These terms and conditions of sale shall apply to all contracts for the purchase of goods from AMG notwithstanding any previous dealings between AMG and the customer except only to the extent (if any) of any modification in the application of these terms and conditions to which AMG will have agreed to in writing.
3. GOODS DESCRIPTION AND SAMPLES: Notwithstanding any description or sample of goods, AMG shall be entitled to vary or modify specifications of goods or materials so long as such variation or modification does not materially affect the characteristics or quality of the goods.
- 4.1. DELIVERY: Unless otherwise specifically provided for in writing the dates of delivery of goods shall be deemed to be approximate only and time of delivery shall not be of the essence of the contract. AMG shall be entitled to deliver goods in instalments. AMG shall not be liable for any direct or indirect loss that may arise for any shortfall in quantities (provided that the Customer shall not be charged for the shortfall in quantities of goods). Upon the expiry of 3 months from the date provided in the contract for delivery, the contract for any amount of shortfall in quantities of goods delivered shall be deemed to be cancelled with no right or claim being due to or by AMG by or to the Customer.
- 4.2. AMG would not normally agree to cancellation or modification of any contract without being fully compensated for the cancellation or modification. Any cancellation or modification must be in writing.
- 5.1. THE PRICE: All prices quoted by AMG are exclusive of VAT. The price for the goods shall be AMG's quoted prices or when no price has been quoted (or a quoted price is no longer valid) the price listed in AMG's published price list current at the date of acceptance of the Customer's order. AMG reserve the right to supply substitute product when necessary. Such substitute products will be supplied at the same price as those products on the original order.
- 5.2. Generally, where an order value is greater than £350 + VAT, all prices are quoted on a "delivered" basis. Where the order is less than £350 + VAT, AMG reserves the right to levy a carriage charge, at the rate prevailing, at the time of order. The terms "delivered" are only applicable to UK domestic orders, dispatched via AMG's standard (48 hours) shipping service. "Express / Next Day" or other such services will be charged at the prevailing rates in force at that time. Sales to countries out with the UK may be subject to freight charges applicable to that country. Minimum order values for "free delivery" to each country must be agreed in writing with the AMG export department.
- 5.3. SURCHARGES: AMG reserve the right to levy customers for external surcharges incurred out with its control, which shall be implemented only after a 14 day notice period has elapsed.
- 5.4. VAT: Shall be payable at the rate included in the VAT invoice.
- 6.1. PAYMENT: Unless otherwise specifically provided in writing, payment of the price will be due by the 20th of the month following the month of supply to the Customer and must be made to AMG.
- 6.2. In the event of failure to pay on the due date (a) interest at 2% per month for the first month and 3% per month for each subsequent month shall be payable from the due date for payment until payment of any outstanding sum due, and (b) all and any discount provided for in the contract or in AMG's invoice shall be cancelled. Any charges relating to the collection of unpaid monies will be for the customer's account.
- 6.3. OWNERSHIP of goods supplied by AMG shall remain with AMG until payment of all monies due to AMG by the customer under this or any other contract have been received in full. The customer shall hold the goods as readily identifiable as the goods of AMG and the customer shall advise AMG where the goods are held.
- 6.4. If the Customer in the ordinary course of business shall purport to dispose of any goods while still in the ownership of AMG all sums paid or payable to the Customer in respect of any such disposal shall belong to AMG and pending payment to AMG shall be held in trust for AMG.
- 6.5. At any time after the due date for payment of goods, AMG shall be entitled to recover possession of any goods for which payment shall not have been made in full and for that purpose the Customer authorises AMG and/or its agents to enter the premises of the Customer where AMG believes the goods to be held.
- 6.6. Notwithstanding that ownership of goods shall not have passed to the Customer AMG shall be entitled to pursue the Customer by way of court action or otherwise for payment for the goods at any time after the due date for payment and that without prejudice to AMG's right in terms of 6.5 above to recover the goods concerned.
- 6.7 In the event of a customer restructuring, following any form of insolvency e.g. CVA, Liquidation, Administration or other such process, AMG reserves the right to cancel or modify any contracts previously in place with that customer.
- 6.8 In the event of a change to the shareholding or ownership of a customer, in excess of 5% of that customer's issued share capital, AMG reserve the right to cancel all outstanding contracts and request immediate payment of all outstanding sums.
- 6.9 AMG reserve the right to withdraw, reduce or cancel any credit terms offered, at its discretion and request (if it so chooses) that the Customer re-apply for such credit terms, which following review of the new application, may or may not be granted.
- 7.1. LIABILITY: AMG's liability under these conditions shall be AMG's whole liability and responsibility to the Customer arising out of the contract for the supply of goods and shall be in lieu of all and any warranties or conditions implied by law as to the quality of goods or their fitness for any particular purpose. Nothing however shall exclude any liability AMG may have for the death or personal injury caused by the negligence of AMG or its employees (except when under the control of the Customer).
- 7.2. AMG shall have no liability for any defect in the goods supplied where such defect would on reasonable inspection have been revealed unless within 5 days of the date of supply the Customer shall have given written intimation of claim to AMG of defects in, loss of, or damage to the goods.
- 7.3. AMG's liability is to supply goods of satisfactory quality which conform to the contract and fit for the purpose so far as is reasonable. AMG shall have no liability for a design or specification that is supplied to AMG by the Customer. AMG shall have no liability for goods not of AMG's own manufacture but the Customer shall be entitled to the benefit of all and any guarantees given to AMG by the makers to the extent that such guarantees are effective and enforceable.
- 7.4. AMG shall not be liable for any failure in performance of its obligations under a contract for the supply of goods, if that failure is caused by factors outside its control.
- 8.1. The use of any AMG's brands or brand logos, in any format, must only be used with the signed prior agreement of AMG.
- 8.2. MARKETING: Any communication medium featuring AMG's brands and/or brands logos which portray the brand(s) in a manner which could be construed as detrimental to AMG or its brands, may result in the closure of the trading account and the cancellation of any outstanding orders.
- 8.3. The marketing and featuring of AMG's products and brands, in any communication, must always be done in a manner that can have no detrimental effect on AMG, the product or brand(s). Companies and/or their customers who fail to comply with these terms may be refused further supplies.
- 8.4. Companies using any of AMG brand logos to solicit the sale of goods via the internet must have the stock available for immediate despatch. All such Companies must confirm in writing their acceptance of AMG's Brand Guidelines.
- 8.5. It is AMG's policy to only supply goods to AMG approved customers. It is agreed, that as an AMG authorised customer, any goods supplied under these Terms & Conditions of Sale, will not be sold to non AMG authorised retailers, without the express written permission, of AMG.
9. PATENT & DESIGN RIGHTS: AMG will indemnify the Customer against any infringement of patent or design rights in regard to the goods except in respect of goods to the Customer's design when the Customer will indemnify AMG against any infringement of patent or design rights.
10. RISK: Risk in respect of goods will pass on completion of delivery of the goods, notwithstanding that ownership of the goods concerned will not pass as referred to in 6.3 above.
11. LAW: This Contract shall be governed by and interpreted in accordance with the Law of Scotland and the Customer agrees to submit to the jurisdiction of the Scottish Courts notwithstanding that AMG may enforce the contract in any other competent jurisdiction.

# INTERNATIONAL DISTRIBUTORS

Australia  
Anso Pty Ltd  
12 Water Road  
Preston  
Victoria 3072  
Australia  
Tel: (61) (0)3 9480 8500  
Fax: (61) (0)3 9480 8555  
Email: sales@ansco.com.au  
Web: www.ansco.com.au  
Contact: Kenn Sellick

Belgium  
CJ Agencies BV  
Hermesweg 28  
3741 GP Baarn  
Tel: +31 (0)35 542 4200  
Email: info@cjagencies.nl

Bulgaria  
Tashev Co.  
kv. Druzhba 60  
5800 Pleven  
Bulgaria  
Tel: (359) 6487 0035  
Email: office@tashev.bg  
Web: www.tashev.bg  
Contact: Gergana Tasheva

Chile  
Tienda Outdoor  
Soc. Com. OD Retailer Ltda.  
San Carlos 188  
Valdivia  
Tel: +56 63-2245055  
Email: ventas@tiendaod.cl  
Web: www.tiendaod.cl

Czech Republic  
Daniel Kadlec  
Sokolovská 1955/278  
190 00 Praha 9  
Tel: +420 737 111 115  
Email: info@vango.cz  
Contact: Daniel Kadlec

Faroe Islands  
P/F Jógvan Weihe  
Stiðjagøta 10  
110 Tórshavn  
Tel: +298 35 38 97  
Email: weihe@weihe.fo  
Contact: Ólavur Weihe

France  
AMG Group Ltd  
2 Kelburn Business Park  
Port Glasgow  
Scotland, PA14 6TD  
Tel: (44) (0) 1475 746000  
Email: export@amg-group.co.uk  
Web: www.amg-group.co.uk

Germany  
Sport-Tech/Rui-Yi-Lin GmbH & Co. KG  
Goldbeckstr. 6  
69493 Hirschberg  
Germany  
Tel.: +49 (0) 6201 84397-25  
Fax: +49 (0) 6201 84397-11  
Email: info@vango-outdoor.de  
Web: www.vango.de  
Contact : Martin Stolz, Max von Babka

Greece  
Tsochatzis S.A.  
263, Iera Odos St.  
12244 Egaleo  
Athens  
Tel: +30 210 5982456  
Email: stamatis@terramare.com.gr  
Web: www.terramare.com.gr

Netherlands  
CJ Agencies BV  
Hermesweg 28  
3741 GP Baarn  
Tel: +31 (0)35 542 4200  
Email: info@cjagencies.nl

Hungary  
Mountex Kft.  
Rózsa utca 16  
2000 Szentendre  
Tel: +36 26 501 220  
Email: mountex@mountex.hu  
Web: www.mountex.hu  
Contact: Dániel Ferenczi

Iceland  
Utivera ehf  
Skeifan 6  
108 Reykjavik  
Iceland  
Tel: (354) 533 4450  
Email: everest@everest.is  
Web: www.everest.is  
Contact: Heidar Ingi Agustsson

India  
Adventure Compass  
Shop 8 & 9, Mahananda Complex  
Tapovan, Rishikesh  
Uttarakhand - 249192  
India  
Tel: (91) 9899 2979 04  
Email: amitmamgain@adventurecompass.in  
Web: www.adventurecompass.in  
Contact: Amit Mamgain

Italy  
Amorini S.R.L.  
Via Del Rame  
44 - Ponte Felcino (PG)  
Italy  
Tel: (39) 7569 1193  
Fax: (39) 7559 13624  
Email: amorini@amorini.it  
Web: www.amorini.it  
Contact: Andrea Meattelli

Iran  
Caribou Outdoor Shop  
No.1049, Vali-e Asr St.  
Tehran  
Iran  
Tel: +98 21 66 46 67 39  
Fax: +98 21 66 48 18 59

Malta  
Adventure Camping Shop Co Ltd  
Dun Karm Street  
Bkara BKR9038  
Malta  
Tel: (356) 2144 3386  
Fax: (356) 2144 3386  
Email: info@adventuremalta.com  
Web: www.adventuremalta.com  
Contact: Silvio Abela

Pakistan  
Ascender  
Office No. 9  
3rd Floor  
Capital Plaza  
G-11 Markaz  
Islamabad  
Tel: +92 51 2830093  
Mobile: +92 333 9980903  
Email: info@ascender.pk  
Web: www.ascender.pk  
Contact: Talha Hasan

Poland  
Polana  
ul. SA,upecka 10  
02-309 Warszawa  
Poland  
Tel: (48) 22 292 3876  
Email: biuro@polana.pl  
Web: www.polana.pl  
Contact: Krzysztof Tomaniak

Portugal  
Altitude-Jogos De Aventuras, LDA  
Rua Joao Saraiva 34 A/B  
1700-250 Lisboa  
Portugal  
Tel: (351) 21 843 5580  
Email: lurdescosta@grupo-expedicao.com  
Contact: Lurdes Costa

Romania  
Maia Outdoor  
Str. Alexandru Lăpuşeanu Nr. 58  
Piatra Neamţ  
Romania  
Tel: +40 732 004004  
Email: dumitrita@maiaoutdoor.ro  
Web: http://www.maiaoutdoor.ro

Spain  
Outdoor Representaciones  
C/ Juan Martínez Arroyo, 3B  
28042 Madrid  
Spain  
Tel: +34 678 412 832  
Email: outdoor@anyde.com

South Africa  
RAM Mountaineering  
Unit 7 Old Mill Park  
22 Old Mill Way  
Ndabeni  
Cape Town  
7405  
Tel: +27 021 532 0549  
Fax: +27 021 531 2844  
Email: info@rammountain.co.za  
Web: www.rammountain.co.za  
Contact: Simon Larsen

South Korea  
Niio Corp Ltd  
A1806, Gabul Great Valley  
32, Digital-ro 9gil  
GeumChun-Gu  
Seoul 08512  
Tel: +82 2 3397 7711  
Fax: +82 2 3397 7718  
Email: trade1@niio.co.kr  
Web: www.niio.co.kr  
Contact: HanJoo Lee

Tanzania  
The African Walking Company  
PO Box 1433  
Arusha  
Tanzania  
Tel: (255) 748 788886  
Email: awc-richard@live.co.uk  
Contact: Rich Marsden

Ukraine  
SVA.KIEV  
Str. Academician Crimean 27A.  
Kiev  
Ukraine  
Tel: +38095-834-02-39  
Fax: +38095-910-57-39  
Email: sale@sva.kiev.ua  
Web: http://www.sva.kiev.ua/

United Arab Emirates  
Global Climbing Trading L.L.C  
PO Box 474476  
Dubai Investment Park 1  
District 598, Street No 77  
Dubai  
United Arab Emirates  
Tel: +971 4 8829 361  
Fax: +971 4 8829 362  
Email: guida@globalclimbing.com  
Contact: Guida Verschut  
Web: www.globalclimbing.com